

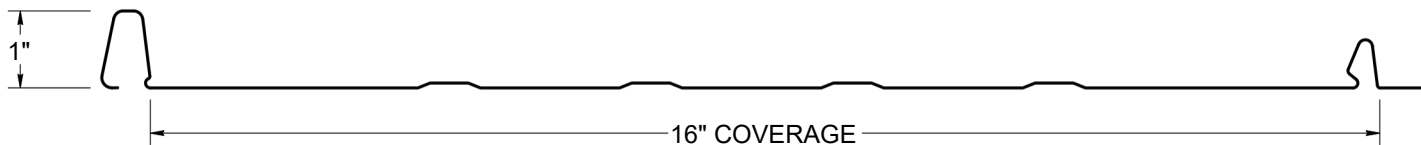

**NOR - CAL**  
METAL PRODUCTS INC

# StreamLine™ Installation Guide

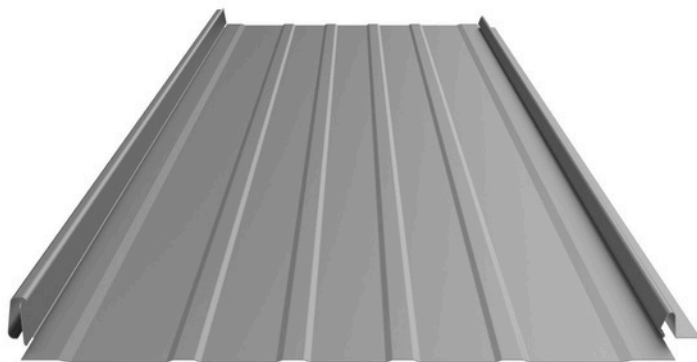
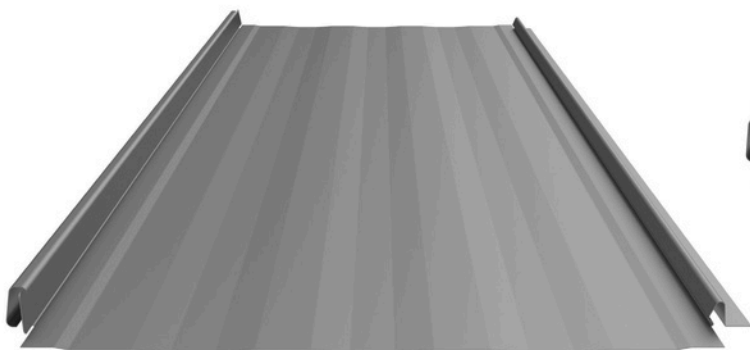

● Panel Specifications.....	4-5	● Valley - High Pitch Detail.....	24
● Introduction.....	6	● Box Gable Detail.....	25
● Handling & Storage.....	7	● Alternate Gable Detail.....	26
● Nor-Cal Delivery Fleet.....	8	● Prow Detail.....	27
● Delivery & Will Call/Loading.....	9	● Sidewall Detail.....	28
● Fasteners.....	10	● Peak Flashing Detail (R.E.C).....	29
● Tools & Equipment.....	11	● WT Peak Flashing Detail (R.E.C)....	30
● Roof Preparation .....	12	● Pitch Change Detail.....	31
● Roof Layout .....	13-14	● Hemmed Endwall Detail.....	32
● Reversing Strip .....	15	● Vented / EW17 Endwall Detail.....	33
● Panel Preparation.....	16	● WT Vented Endwall Detail.....	34
● Panel Installation.....	17	● Eave to Gable Transition.....	35-37
● Low Pitch Eave Detail.....	18	● Skylight/Chimney.....	38-40
● Hook Eave Detail.....	19	● Pipe Penetration - On Plate.....	41
● Hook Eave with Gutter Detail.....	20	● Pipe Penetration - On Rib.....	42-43
● Hip/Ridge Detail.....	21	● Pipe Penetration - On Pan.....	44
● Vented Ridge Detail.....	22	● Flashing Selection.....	45-51
● WT Vented Ridge Detail.....	23	●	

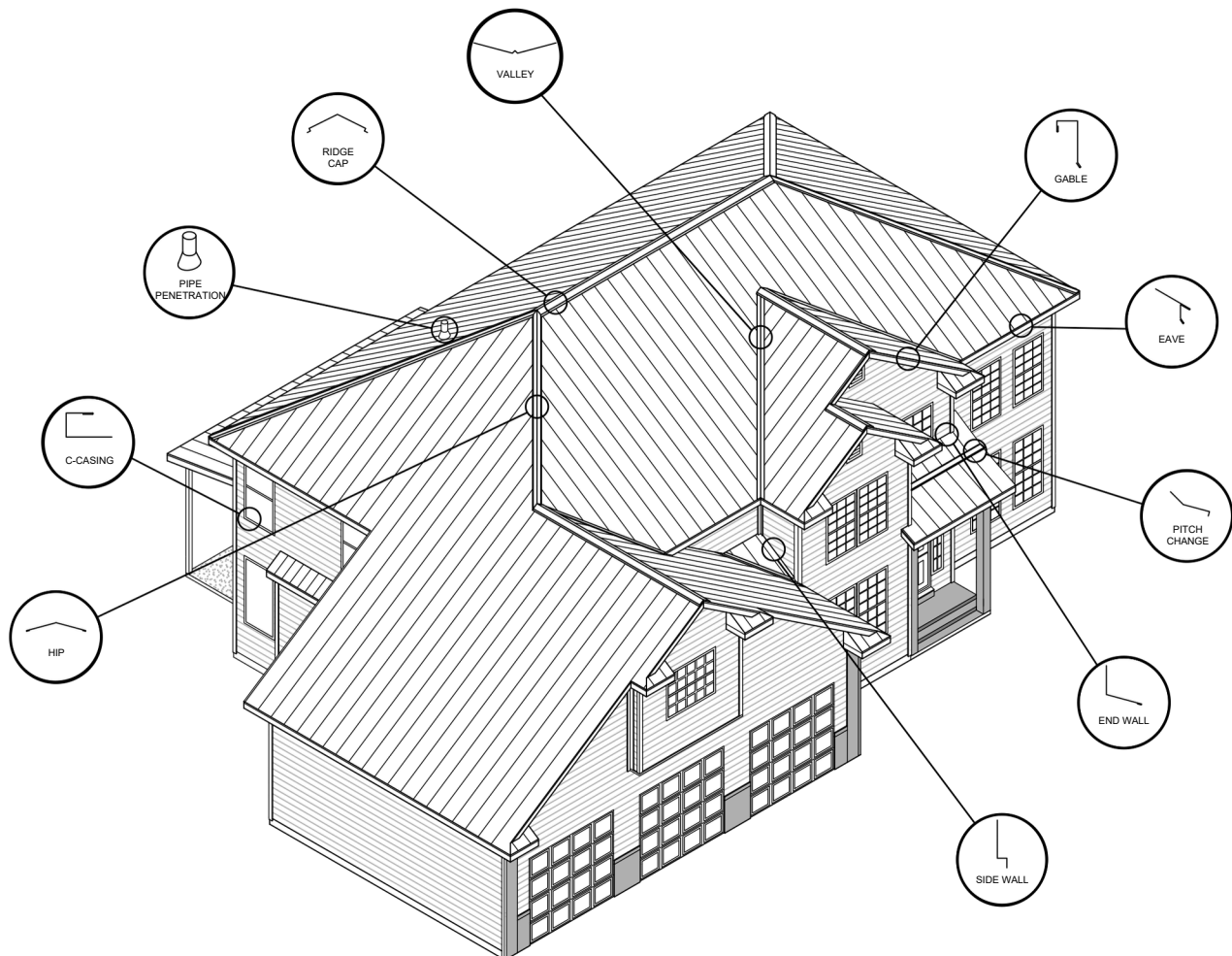



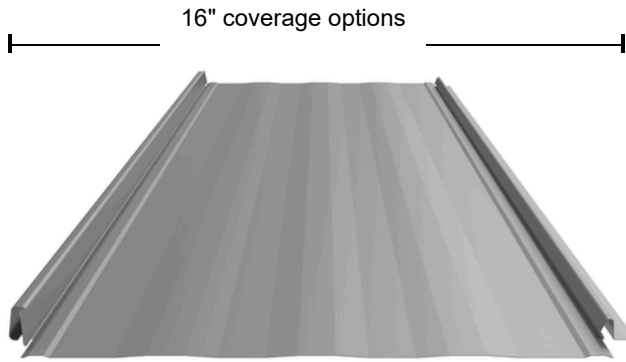

**STRIATIONS**

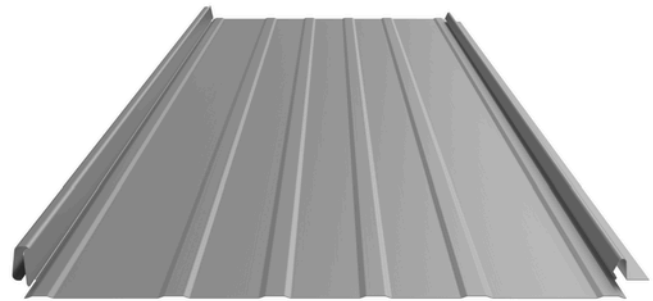

**ACCENT RIBS**

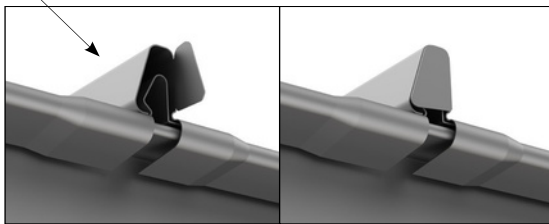

Tabbing feature can help minimize debris from entering in between seams, and gives a more finished appearance.

**LOCK SEAM DETAIL      REVERSE LAP DETAIL**

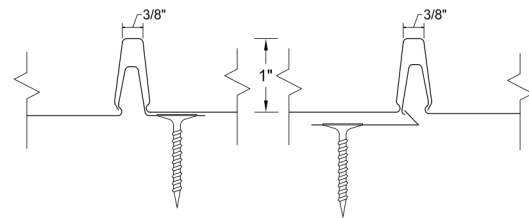

## KEY FEATURES

- 16" Coverage Option
- 26 Tru-Gauge™ ArmorTech™ SMP Painted Steel
- Factory-notched and tabbed panels available
- Vertical interlocking application: allows installation from both directions starting at any location
- Patented no-siphon lock seam
- 1" vertical rib with 3/8" flat top for ease of flashing attachment
- Concealed fasteners: fasteners cannot leak
- Pre-slotted fastener flange: allows expansion / contraction of panel (high wind clips available for panel lengths over 35')
- 3:12 minimum pitch recommended  
*(For lower pitches, please inquire)*
- Standard panel lengths 4' to 35' - not notched  
Standard panel lengths 1' to 35' - notched and tabbed  
*(For longer panels, please inquire)*
- Manufactured in Sacramento, Ca
- Panel options: Striations and AccentRibs

## TESTING

-  Code compliance UL Evaluation Report UL ER #25913-01
- UL Construction No. 529
- UL 580 Class 90 - Wind Uplift
- UL 790 Class A (ASTM E108) - Fire rated
- UL 2218 Class 4 - Impact (hail) rated
- ASTM A653/A924 - G90 Galvanized
- ASTM A792 - Zincolume/Galvalume AZ-50/55
- ASTM B209 - Aluminum Substrate
- ASTM E2886 - Ember Resistant ridge/endwall/peak

flashings available



The StreamLine™ Standing Seam is the only metal roofing panel with a patented no-siphon dry lock seam, with a unique reversing feature to allow installation of panels from both directions starting at any location. The panel is designed with softer, less industrial lines to provide an architecturally pleasing appearance.

## MATERIAL SPECIFICATIONS

- 26 gauge ArmorTech™ SMP Painted Steel G-90 Galvanized or AZ-50
- 26 gauge bare Zincolume® Plus AZ-55  
(No finish warranty – 25 yr. perforation warranty)
- 26 gauge bare G-90 Galvanized  
(Nofinishwarranty–noperforation warranty)
- Zincolume & Zincolume® Plus are registered trademarks of Bluescope Ltd. Galvalume® is a registered trademark of BIEC International, Inc. Vintage® is a registered trademark of Steelscape, Inc. Kynar® and Kynar 500® is a registered trademarks of Arkema, Inc.

Standard Weight				
Width	Gauge	Color	LBS SQFT	LBS LF
16"	26	ArmorTech	1.054	1.402

## FINISHES

- 18 Standard Colors, Zincolume® Plus, and Galvanized G-90
- ArmorTech™ Paint System - excellent in exterior durability
- “Cool” color pigments are specially designed to reflect infrared light, reducing heat gain to dwelling, and conform with ENERGY STAR® criteria
- Superior quality, two coat SMP resin system at 1 mil. thickness
- 40-year residential paint warranty

- fading
- chalking
- chipping
- cracking
- peeling

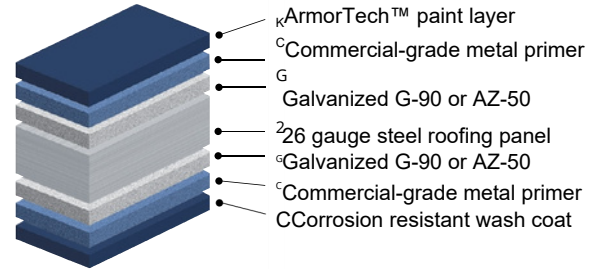

## 40-Year Residential Manufacturer's Limited Warranty

### STANDARD COOL ARMORTECH™ SMP COLORS



These printed chips provide a close representation of the colors.

Metal samples are available upon request. Coatings are low gloss 10-15% sheen. SRI = Solar Reflective Index. SRI values listed above are in accordance with ASTM E1980 and are based on actual testing. \*\*\*Oil Canning is not a cause for material rejection\*\*\*



# Introduction

Nor-Cal Metals, **StreamLine™** Standing Seam roofing panels are designed for residential and light commercial applications, however it is not limited to these uses. The StreamLine™ Standing Seam concealed fastener roofing system is an architectural roofing system and is designed to be weather tight, attractive, easy to install and to provide long life. These installation instructions are intended to offer suggested application procedures for common building construction. No attempt is made to provide installation details for every application or possible use. Please contact Nor-Cal Metal Products for use of custom flashing details as they pertain to specific conditions or to discuss a specific project. Conformity to local building codes, details for specific applications, and use of safety and health procedures is the sole responsibility of the installer. Nor-Cal Metal Products, assumes no liability for the improper installation of the StreamLine™ panel nor for any personal injury or property damage that may occur with the product's use.

*\*Oil Canning - All light gauge metals can display waviness often referred to as "oil canning." This is caused by steel mill tolerances, substrate variation and relative reflectivity. "Oil canning" is an inherent characteristic of steel products, not a defect, and is not a cause for material rejection.*

## Handling

Handle materials with care when off loading or moving materials to avoid damage to panels or flashings. Long panels may require two or more pick-up points, properly spaced to avoid damaging panels. Plan ahead. Contact Nor-Cal Metals for recommendations on handling/hoisting long panels. Wear clean cotton gloves when handling copper or unpainted Zincolume® to avoid leaving fingerprints and smudges. While fingerprints or smudges will not harm the material, they will temporarily leave markings on the material until the material weathers. Wear clean, soft-soled shoes when walking on roofing panels to avoid damage to the painted finish. Take care that sand, gravel, dirt etc. sticking to your shoes is not carried onto the roof, scratching or otherwise damaging the finish on the roofing material. Walking on asphalt impregnated felt paper, especially on a hot day, can cause the asphalt to stick to your shoes and be tracked onto the roofing material. Do not walk on major ribs of panels. Do not walk on panels that have not been completely installed. Take care when painting to avoid getting over spray on the roofing material. Remember that wind can carry paint particles some distance. Over spray can cause the finish of the roofing material to look dull and may void your warranty. Do not allow panels to contact preservative-treated lumber. Water and ice shield material is effective in preventing a corrosive reaction between steel products and pressure-treated lumber.

## Storage

Store the panels, flashings, and accessories in a dry, well ventilated area, on level ground. Slightly elevate one end of bundles to allow drainage of wet materials. Support panels with blocks throughout escalation in elevation to prevent permanent deformation. If covering, allow ventilation around the panels. Protect panels against standing water and condensation between adjacent surfaces. If panels become wet, immediately separate sheets, wipe dry with clean cloth, and keep sheets separate for air-drying. Painted metal roofing panels will have a clear plastic film applied to the lower rib of the panel to protect the seam during transportation and handling. Flashing and flat sheet may have a plastic film for protection. Remove this film prior to installation of the panels. Products with film should not be stored in direct sunlight or under other UV source, and should not be left in extreme heat or cold for long periods. Secure materials on the ground or roof to prevent winds from moving the materials, especially when leaving the site. Wind-blown materials may cause damage to the material, property or persons. Avoid installing panels in windy conditions. Safety considerations are the responsibility of the installer and their crew. Be sure to **use common sense** and accepted industry standard safety practices when installing roofing materials. Always use proper safety equipment and attire to minimize risk of cuts or other injuries.

## Delivery Fleet

Nor-Cal Metal Products prides itself with quick lead times delivered with our fleet of semi trucks. Our fleet of trucks are owned and operated by NMP. All of our drivers are Nor-Cal Metal Products employees, so when your truck rolls in to deliver, you are dealing with Nor-Cal Metal Products.

Expect consistent and exceptional service with short lead times. The inhouse fleet allows for efficient and cost-effective delivery.



Mounted on the rear of our semitrailer, the trailer-mounted "piggy-back" forklift will accompany you right to your place of use, opening up unprecedented possibilities in terms of transportation. It can travel sideways, carrying panels up to 40' long, allowing delivery in locations that would typically be considered impossible to reach.

Save time and effort while avoiding potential loading and transport issues; have experienced NMP personnel deliver and unload your order.



## Delivery

We will make every attempt to deliver material to the desired location. We may be unable to gain access on tight corners or steep terrain. If the site is deemed inaccessible by our driver, the customer may choose an alternate delivery site within a reasonable proximity. If we are unable to make the alternate delivery, additional charges may be assessed.

The customer is responsible for:

- Determining adequate access for delivery ahead of time.
- Meeting the delivery at the agreed upon time.
- Providing adequate resources (1-4 people as needed) for off loading materials.

***A charge of \$100 per hour may be added for deliveries that go beyond their allotted time.***

- Checking the shipment at the time of delivery.
- Verifying material quantities against the shipping/packing list.
- Noting any damage or discrepancies upon the paper work at the time of delivery and notifying Nor-Cal Metal Products within 48 hours of delivery.

Delivery times are usually scheduled one day in advance. Nor-Cal Metal Products will make every effort to make the delivery at the scheduled time. Please be aware that there may be conditions beyond our control such as traffic, mechanical failures, road closures, etc. which may affect our schedule. If a delay is expected, you will be notified in advance of delivery.

## Will Call/Loading

Flatbed trailers and trucks are best suited to transport metal roofing materials. These can be loaded from the side with a forklift and tied down in a safe and secure manner.

We are not able to load materials onto vehicles and/or trailers which are not suitable or may be hazardous to load. Please be aware that if we find a vehicle to be inappropriate, we reserve the right to refuse to load your order.







Unacceptable examples include: boat trailers, vans, buses, motor homes, campers and box trailers. Pickup racks which do not have sufficient supports for the weight or are not long enough to support bundles are also unacceptable.

Nor-Cal Metal Products is **not** responsible to tie down loads nor do we provide any tie down materials. Please bring tie downs to secure your load (string or twine are **not** acceptable for this purpose).

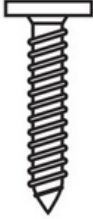
**Consider having your order delivered on one of our trucks with a piggy back forklift.**



NMP recommends the following fasteners:

FASTENER	DESCRIPTION	USE
	<p><b>Pancake Head, Sharp point</b> #10 x 1" #2 Phillips Head</p>	<p>The pancake head screw is recommended for panel attachment and is a concealed fastener.</p>
	<p><b>Waferhead Screw, Sharp point</b> #9-16 x 1" #2 Phillips/Square Drive #9-16 x 1-1/2" #2 Square Drive</p>	<p>Waferhead screws are used for attaching the panels to a wood deck or substrate. They are concealed fasteners and made of carbon steel coated with Zinc and an Oxyseal/Xylon Coating for long life.</p>
	<p><b>Lath Head Screw, Sharp Point</b> #8 x 9/16"</p>	<p>While generally not recommended for most applications, this concealed fastener is useful for areas where a longer fastener will penetrate the substrate and exhibit an objectionable appearance, such as exposed overhangs. The pull out rating for this fastener is less than the waferhead, so these fasteners need to be placed more often.</p>
	<p><b>Woodfast Screw, Sharp Point</b> #9-16 x 1" 1/4 Hex Drive-Color Match to wood in some cases metal to metal. They are exposed</p> <p>#9-16 x 1/2" 1/4"</p>	<p>Woodfast screws are recommended for attaching metal fasteners.</p>
	<p><b>Stitch Screw, Sharp Point</b> #12x3/4" 1/4 Hex Drive-Color Match</p>	<p>Stitch Screws are used to attach metal to metal such as lap joints in flashing. They can be used interchangeably with rivets.</p>
	<p><b>Rivets</b> #43 (1/8" x 1/8") Stainless Steel rivet Color Matched or non-painted</p>	<p>Rivets are used to attach metal to metal such as lap joints in flashing.</p>

## The following tools/safety equipment may be used for proper installation:

- Screw Gun: Clutch type, variable torque, cordless screw guns will give the best results.
  - Extra batteries
  - Bit holder - magnetic
  - #2 square drive bits or philips drive bits (for panel screws)
  - 1/4" Hex head - magnetic - bit driver (for woodfast flashing screws)
  - 1/8" drill bit (for rivets & pre-drilling fastener holes)
  - Belt & holster (keeps all the above tools safely on your hip)

### Cutting Tools:

- Cutters/Offset (curved jaw) left & right (for precision cutting, long cuts)
- Snips (straight jaw) left & right (for short cuts & circular cuts)
- Electric Shears (aids in long panel rips)

**CAUTION: POWER SAWS MAY CAUSE PANEL DAMAGE!**

**NMP recommends cutting panels and flashings with tin snips or shears.**

**We do *NOT* recommend the use of saw blades or abrasive wheels - use may void warranties and reduce longevity, especially in marine environments.**

***WARNING : Filings, debris and metal chips must be wiped off panels each day to avoid corroding the panels and causing rust specks or stains. Water can cause non-finished metal shaving to bind to panels after rust develops damaging panels. Failure to properly install panels and remove debris may void the warranty.***

### Other Tools:

- DeBurring Tool
- Hole Punch (for pre-punching holes in metal)
- Rubber Mallet - SoftType (for adjusting panels & flashings)
- Quick Square, Framing Square & Bevel Square (aids in squaring flashings & panels) Duck Bill Vise Grips/Pliers (for various bending)
- Upender Tools (used for panel-prep, available at NMP)
- Tape Measure
- Rivet Tool (for riveting flashings)
- Marking pen or grease pencil
- Chalk Line (for marking long panel rips and to align panels)
- Protective gloves to protect hands
- Cotton gloves for working with copper (to protect against fingerprints on finish)
- Ear plugs
- Safety harness kit

## New Construction

Nor-Cal Metal Products StreamLine™ Standing Seam roofing products can be installed for either new or re-roofing applications. We recommend installing the StreamLine™ Standing Seam over a rigid continuous substrate such as plywood sheathing or decking. We recommend that the plywood be 15/32" or thicker or 22 ga metal deck. For best results the substrate should be smooth, flat and free of debris. Cover the entire roof area with 30 lb. ASTM rated felt paper. Apply the felt by rolling it out horizontally across the roof starting at the eave. Allow a 3" overlap for each course. Lap end joints 6". Maintain the rule of keeping uphill courses lapped on top of downhill courses of felt. Tears and cuts should be replaced with new felt or repaired with roofing lap cement. To prevent bonding between the copper and roofing felt, a layer of smooth building paper or a rosin sized slip sheet should be laid over the felt before installing the copper roofing.

## Re-Roofing

The StreamLine™ Standing Seam can be installed with felt over most existing asphalt, composition, fiberglass shingles or rolled roofing. Tile, gravel, wood shingles/shake, metal or any other type of roofing material should be removed to the bare sheathing. Inspect the substrate for damage or rot and replace sheathing as necessary. Apply the underlayment as described above.

Consider the following when installing the metal roofing over existing roofing materials:

- Building Codes: Local building codes will typically limit the number of layers of roofing allowed. Check with your agency.

- Solid Fastening: Check the condition of the substrate.

Damaged or rotted plywood or decking will not provide for secure fastening. Repair or replace damaged or rotted substrates.

- Appearance: Irregular substrates may affect the overall appearance of the metal roofing product. Panel deformation may occur, however, product integrity will not be affected.

- Roof surface: Any warped or loose shingles must be nailed down along with any protruding nail heads. Remove all moss and other debris, including existing starter strips. Cut off all overhanging shingles and remove hip and ridge caps.
- Ventilation: Trapped moisture can cause premature failure of the metal roofing product as well as substrate, insulation etc. Provide adequate ventilation and appropriate moisture protection.

## Ventilation

Proper ventilation is necessary for full roof life. Check local codes for venting requirements. To provide for ridge and/or hip ventilation, remove (for retrofit) or leave out (for new construction) 2" of sheathing on both sides of the ridge center. Cover opening with flyscreen and secure the flyscreen with staples. Apply felt paper up to the edge of opening as explained in "Underlayment" section. Nor-Cal Metal Products recommends allowing ventilation between the outer roof deck and the insulation. Lack of ventilation may trap moisture. The rib of the panel is not a source of ventilation for the area beneath the roofing panels.

## Insulation

Check with your design professional or insulation consultant for applications or design details. Also check local building codes to ensure compliance.

## Touch-Up Paint

Most of the time touch-up paint is supplied in spray cans. Spray cans are useful for painting large areas such as downspouts, pipe flashings, and other pre-existing areas.

### Scratches and scuffs in the finish should be

**touched-up but not sprayed.** The paint should be well mixed and sprayed into a small container, then applied to scratches with a very fine brush or toothpick, just filling in the scratch. If the area is sprayed over, the differences in the chemical makeup will likely cause the touch-up paint to fade differently than the baked-on finish and cause a blotchy appearance over time.

Paint pens are offered in most Kynar® colors and work best for covering minor scratches, please inquire for color options. Paint pens not available for ArmorTech™ panels.

It is important to get the roofing panels installed straight and you can't always depend on the gable/rake edge to be straight. After the underlayment has been applied you must now lay out an alignment line at the gable edge to align your first panel. You can use either of the following methods to check the gable edge to ensure the first panel gets started straight.

## Method #1: 3-4-5 Triangle

The first method utilizes the 3-4-5 triangle method. After the underlayment has been applied, you must now lay out a grid line along the gable edge to align your first panel. Here we are using a 3-4-5 triangle in increments of 9'-12'-15' (e.g.  $3 \times 3 = 9$ ,  $3 \times 4 = 12$ ,  $3 \times 5 = 15$ ). For longer panels use larger multipliers ( $5 \times 3 = 15$ ,  $5 \times 4 = 20$ ,  $5 \times 5 = 25$ ).

**Step 1:** Snap an alignment line 2 feet from the eave.

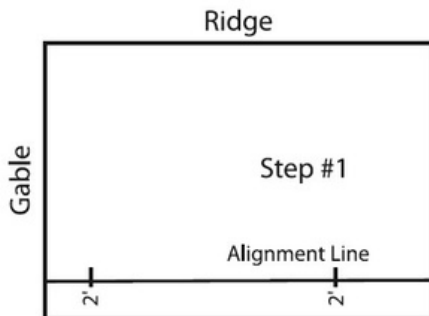

**Step 2:** Start from a point (datum) on the alignment line 1/4" to 1/2" from the left (or right depending on which edge you're starting from). Establish a 12' arc from datum point.

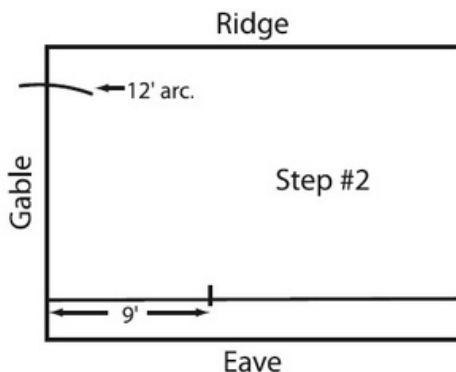

**Step 3:** Measure 9 feet from the datum point along the alignment line and establish a reference point there.

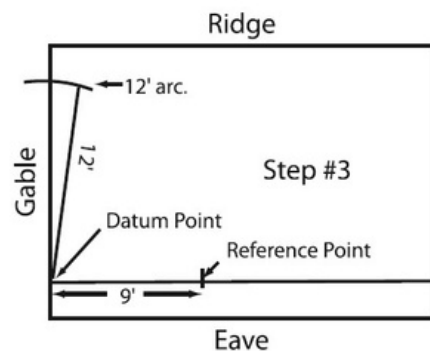

**Step 4:** From the reference point make a 15-foot arc to intersect the 12-foot arc. Snap a chalk line from the intersection point to the datum point. You now have a straight edge to align your first panel along the gable.

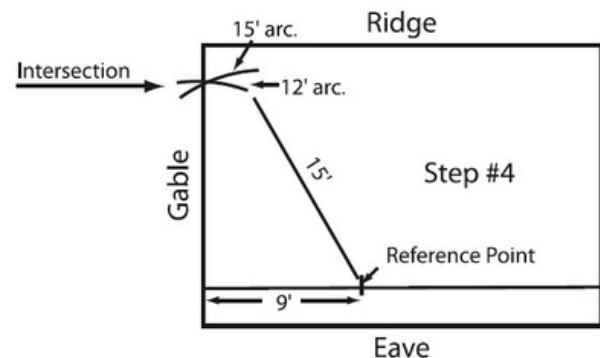

**Step 5:** If you have valleys: Since your underlayment will cover the true center line of your valleys, snap lines at these areas for aligning valley flashings.

## Method #2: Framing Square

The second method utilizes a framing square. Begin by stretching a string line from corner to corner at the eave edge. After the eave flashings are installed, lay down your first panel and square it at the eave using a framing square along the screw flange edge of the panel and squaring to the string line. Once square, secure alignment panel by putting one panel screw in at the bottom and at the top. If a gable roof, check for the gable side of the panel to be no more than 3/8" off square. The standard gable flashing will compensate up to 3/8". If more than 3/8", a compensating gable flashing will need to be used.

Another method is to rip the first panel at the correct angle and to up-end the ripped edge 1" at 90 degrees and use the standard gable flashing. It may be required to rip the last panel. For extreme out of square conditions, consider using a Prow Flashing.

## ProwRoofs

For a prow roof, use the same procedure above to square the first panel. Go to the top and measure the distance from the prow side of the first full panel to the top of the prow edge. (The prow flashing should be installed first; allow for 2" between the prow pan up-leg and the rib of the first full panel).

For example, if your measurement was 3' - make a pencil mark on the framing square for this measurement.

It is critical to maintain and square with the eave. Snap a chalk line from the top mark to the bottom mark. This will be the actual line you will set your first prow panel on. Also, it will give you the angle required to rip your first, second and third prow panels.

Install the first two prow panels and remove the first full-length panel before installing the third prow panel. If you're accurate on your squaring, cuts and alignment, your first full-length panel will be square to the eave line. (See (a) Dotted line is 2" gap.)

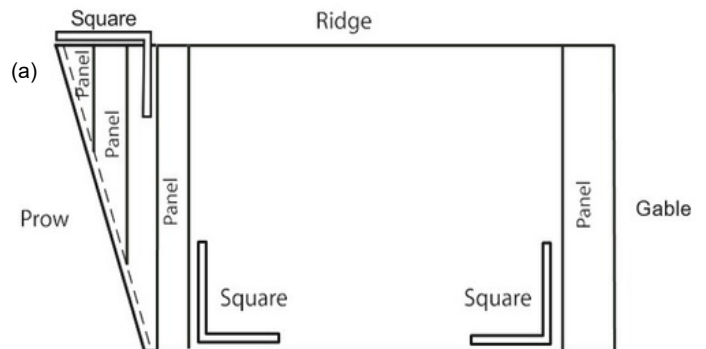

## Hip Roofs

Hip roofs present some challenges to panel alignment. The easiest method of aligning panels on a hip roof is to start in the center of the roof area and use the "Reversing Strip" (see page 13) to install the panels starting at center and installing panels in both directions (left & right).

Use either method of panel alignment to be sure the panels are straight and centered. Position the reversing strip at the center point and fasten into place. Then install the panels as indicated. Incidentally, you can also start the panels at center on a gable roof and work both directions.

Alternately you can align panels on a hip roof by starting with a longer panel (5' to 7') in length. Place the panel in the appropriate spot (usually 5' to 7') from the left or the right and use either method of aligning the panels to get a straight line to work from. Install this panel, and then work back to install the shorter panels and then the rest of the panels as usual.

**\*Reversing Strip suitable for use with StreamLine™ or Easy-Lockpanels ONLY.**

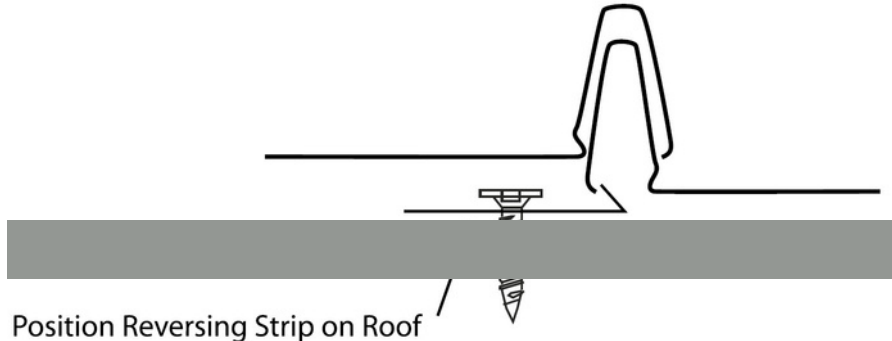

The reversing strip allows the StreamLine™ panels to be installed working both left and right. The reversing strip is most commonly used on hip roof applications although it can be used on other roof styles.



### Reversing Strip Application

**Step 1:** Locate the center of the roof section you are working on. Use 3-4-5 Triangle or Framing Square Method. See (a)

Snap a straight line on the mark perpendicular to the eave line. It is important that the line is straight, so that the panels will be straight.

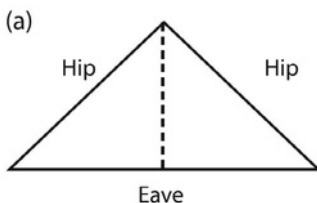

Position the turned edge of the reversing strip along the center-line and fasten to the sheathing every 18" to 24" with a waferhead screw. It won't matter which direction the strip faces.

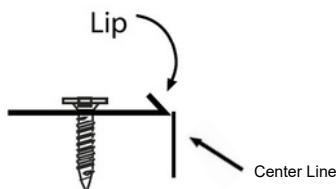

**Step 2:** Place a panel of the appropriate length on the roof and hook the lock lip of the panel (located on the upper/female rib) to the lip of the reversing strip. See (b)

Pull the panel so it fits tightly into reversing strip and fasten the panel to the sheathing with waferhead screws.

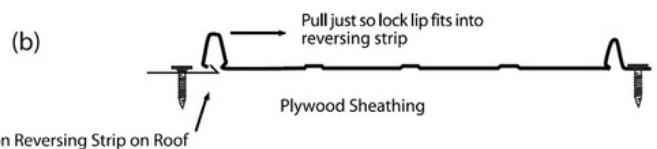

**Step 3:** Position the next panel so that the female rib is over the female rib of the previous panel laying the opposite direction. Press down until the panel is locked onto the previous panel. Fasten that panel in place.

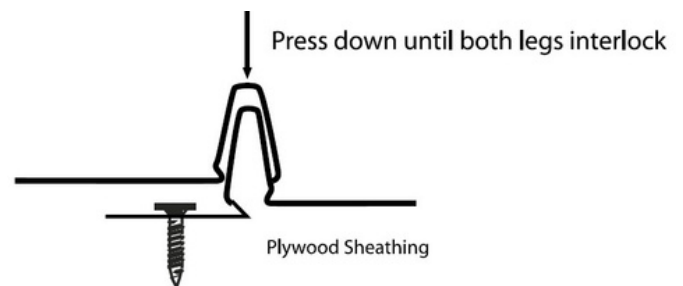

**Caution:** We do not recommend reversing panels on the same pitch when using metallic colors (i.e. weathered zinc or copper penny) or Zinalume®. The paint/coating will reflect differently when the panels are reversed and could look like a different color.

## Top of Panel - Upend

To up-end panels, snip the pan  $7/8$ " beside the female rib, and  $7/8$ " at  $1/4$ " from the inside of the male leg. The up-end tool makes an accurate marking template. After snipping  $7/8$ " cuts, place up-end tool into pan and bend up to just over 90 degrees. The up-end acts as a baffle. The  $1/4$ " gap at the screw flange allows for clearance to snap in the next panel. You will need to fill the gap at each side of the upended panel with flex seal. (Figure 1)

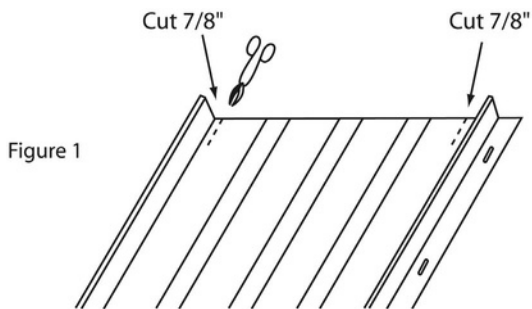

## Bottom of Panel

Snip off the corner of the fastening flange approximately  $45^\circ$  for appearance. (Figure 2)

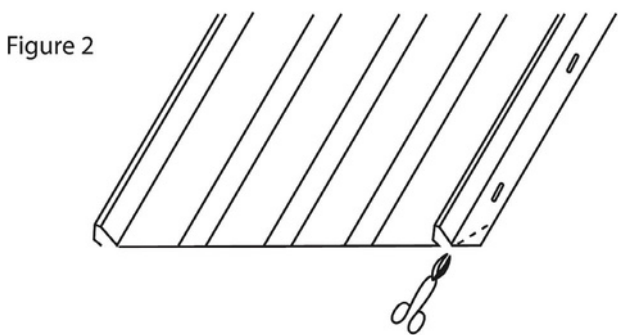

## For Low Pitch Applications

### Alternate #1

On pitches of less than  $3/12$ , place up-end tool into pan, bend down and under to form an open hem under the pan. This step brings the pan edge below the eave flashing edge which stops any potential wicking or siphoning. (Figure 3)

If using this method, allow for an additional  $1/2$ " of panel length.

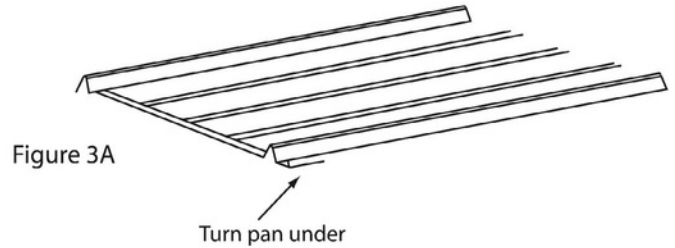
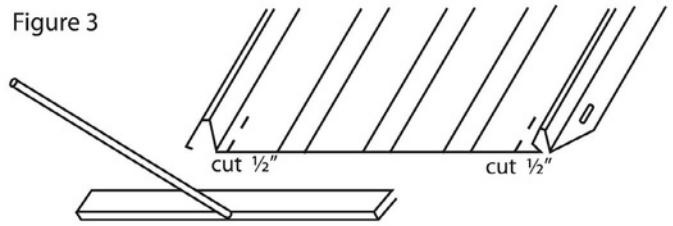

### Alternate#2

On pitches of less than  $3/12$ , use a  $1/2$ " bending tool or other bending tool and make a  $30^\circ$  bend (down) to form a drip edge on the pan of the panel. (Figure 4)

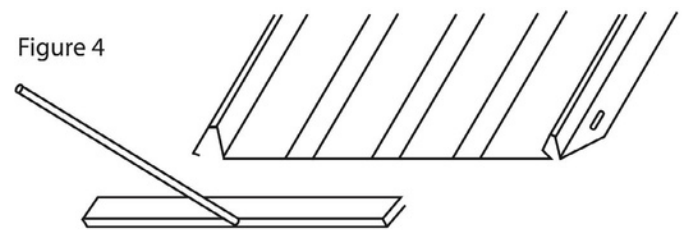

**Note: Nor-Cal Metal Products minimum slope recommendation is  $3/12$  pitch.** On projects less than  $3/12$ , contact a Nor-Cal Metal Products sales representative with project specifics.

## Prior to Panel Installation:

**Before you can install the panels you need to install Underlayment (i.e. Felt Paper), Flyscreen, Eave Flashing, Valley Flashing, Prow Gable Flashing, and other flashings as conditions apply.**

Consider the following before ordering and/or installing roofing panels or flashing. The roof area will rarely come out to the even foot. If working on a gable roof and the incremental distance from gable end to gable end is 4" or less (i.e. 48' 4") consider using the compensating gable flashing. This flashing is used to compensate up to 2" on either one or both ends of the roof. The beginning panel can be started 2" in for the edge and end 2" for the opposite edge. Although to maintain a visually consistent appearance on each gable end, NMP recommends using compensation gable on both ends, rather than standard gable on one end and compensating gable on the other. Using the compensation gable flashing will keep you from having to cut a narrow panel for one end of the roof and will produce a more appealing visual appearance. Compensating gable flashing is also useful if the roof is out of square and can take up 2" of top to bottom differential. In the rare case that you should experience difficulty installing a panel due to a factory defect **stop immediately** and contact Nor-Cal Metal Products. Roof longevity may be compromised and warranty voided by knowingly installing faulty panels. NMP will not be responsible for panels installed with defects. NMP reserves the right to correct the issue before providing replacement panels.

## First Panel Installation:

You may install the panels working from left to right or right to left. It is a matter of choice and convenience. Determine which direction the panels are to be installed before preparing the panel.

Align the upper (female) leg of the panels along the alignment line you made along the gable edge. Allow the panel to overhang at the eave edge 1" to 1-1/4". Apply double row of non-skinning butyl or single row of double bead butyl tape along the eave flashing, position the panel and fasten the panel into place using the waferhead screws. Be certain screw heads are level and flush to the screw flange or they may dent or show through the next panel.

## Second and Successive Panels:

Apply the bead of caulking on the eave flashing (see Eave Section, page 16) and place panels flush along the eave edge maintaining the overhang established on the first panel.

Position the female leg of the next panel over the male leg of the panel previously installed and lock the panels into place using light hand pressure, foot pressure or tap in place with a rubber mallet. Lock the panels from the bottom up. When the rib is locked into place and in the proper position, fasten the panel into place with waferhead screw s.

Repeat for successive panels.

## LOW PITCH EAVE DETAIL

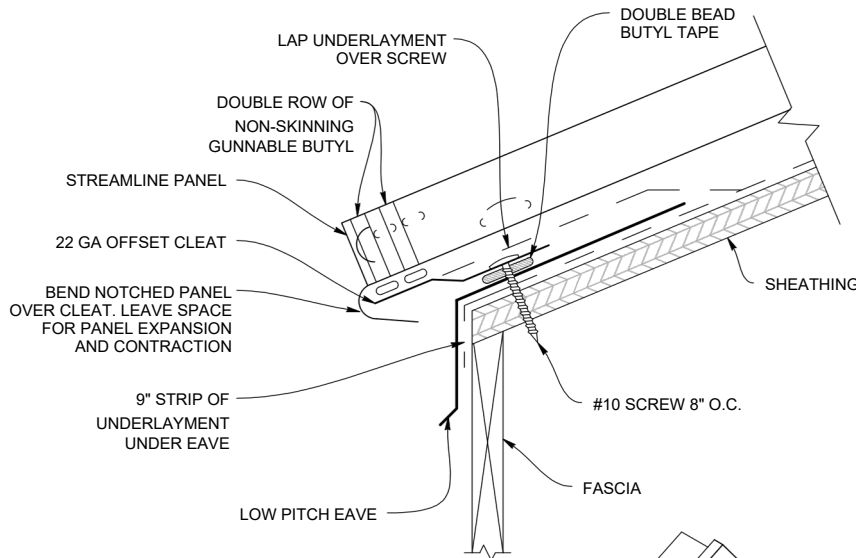

## LOW PITCH EAVE (SLELP)

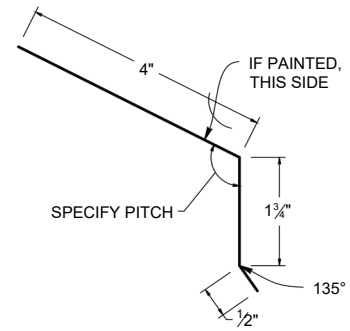

SEALANT REQUIRED UNDER FLAT AS SHOWN IN WET ENVIRONMENTS ONLY (COASTAL / MARINE AND WEST CASCADE MTNS)

#10 SCREW 8" O.C.

NON-SKINNING GUNNABLE BUTYL

2" GAP IN BUTYL

STREAMLINE PANEL

UNDERLAYMENT SHEET

SHEATHING

9" UNDERLAYMENT SHEET

HOOK EAVE

FASCIA BOARD

### Low Pitch Eave Flashing Application

- Install eave flashing prior to panel installation. (If gutters are installed you may need to notch out for gutter fasteners.)
- Use Waferhead Screws and fasten to substrate 18" to 24" or as needed.
- Allow 1" to 2" lap and apply sealant to overlap.
- Apply 2-1/4" beads of sealant along top of leg of eave flashing, 1" +/- from outside edge. (You may also use butyl mastic.)
- Install fascia leg into gutter.
- Insulate between dissimilar metals.

**Note: Customize flashing for more or less coverage.**

**Note: If you experience panel crowning, back bend panels at bottom of panel or turn down edge.**

## HOOK EAVE DETAIL

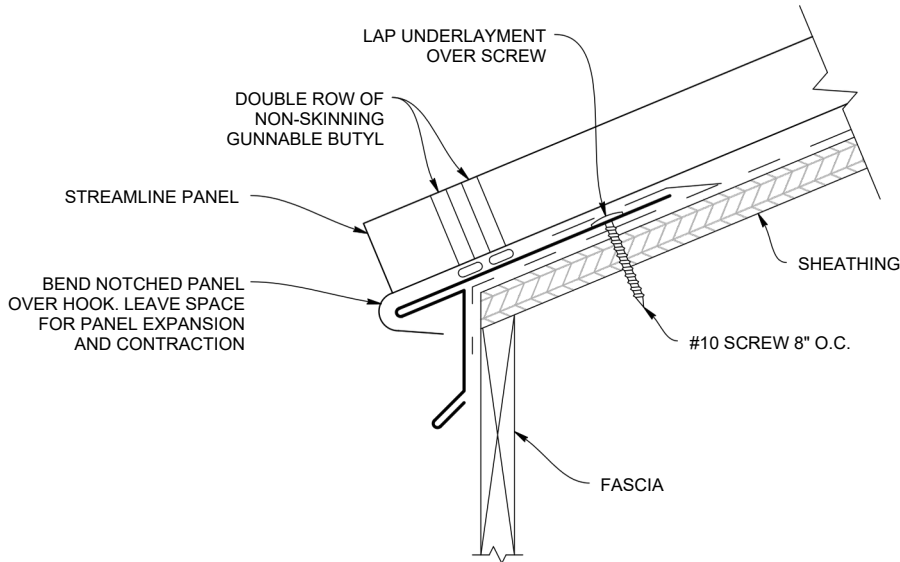

## HOOK EAVE (SLEH)

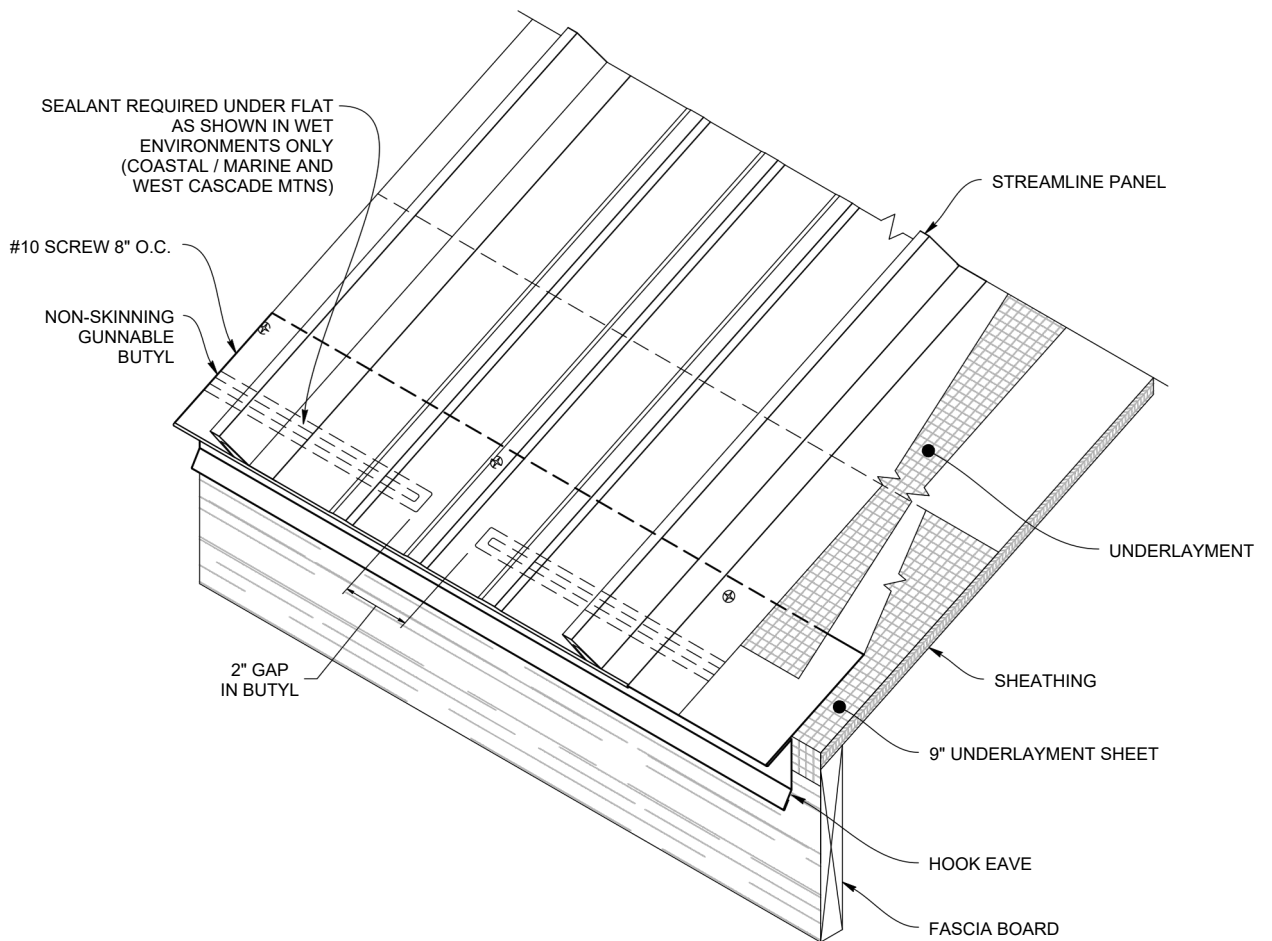
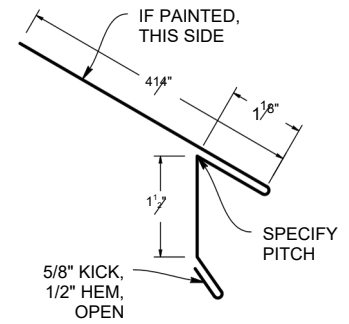

## GUTTER HOOK EAVE DETAIL

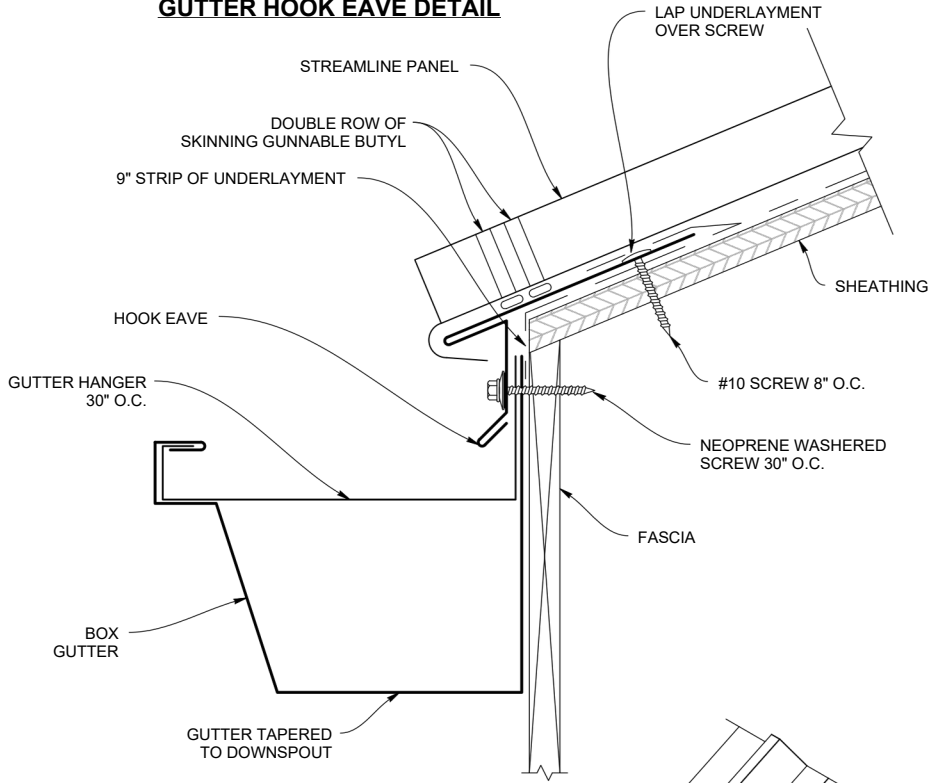

## BOX GUTTER (SL65BG)

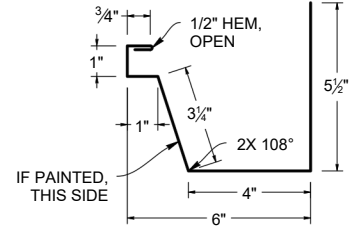

## HOOK EAVE (SLEH)

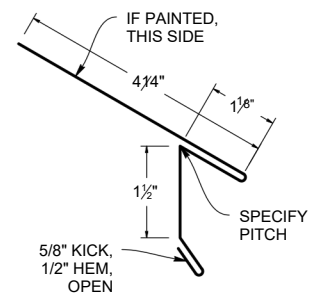

## BOX GUTTER HANGER (AGH6)

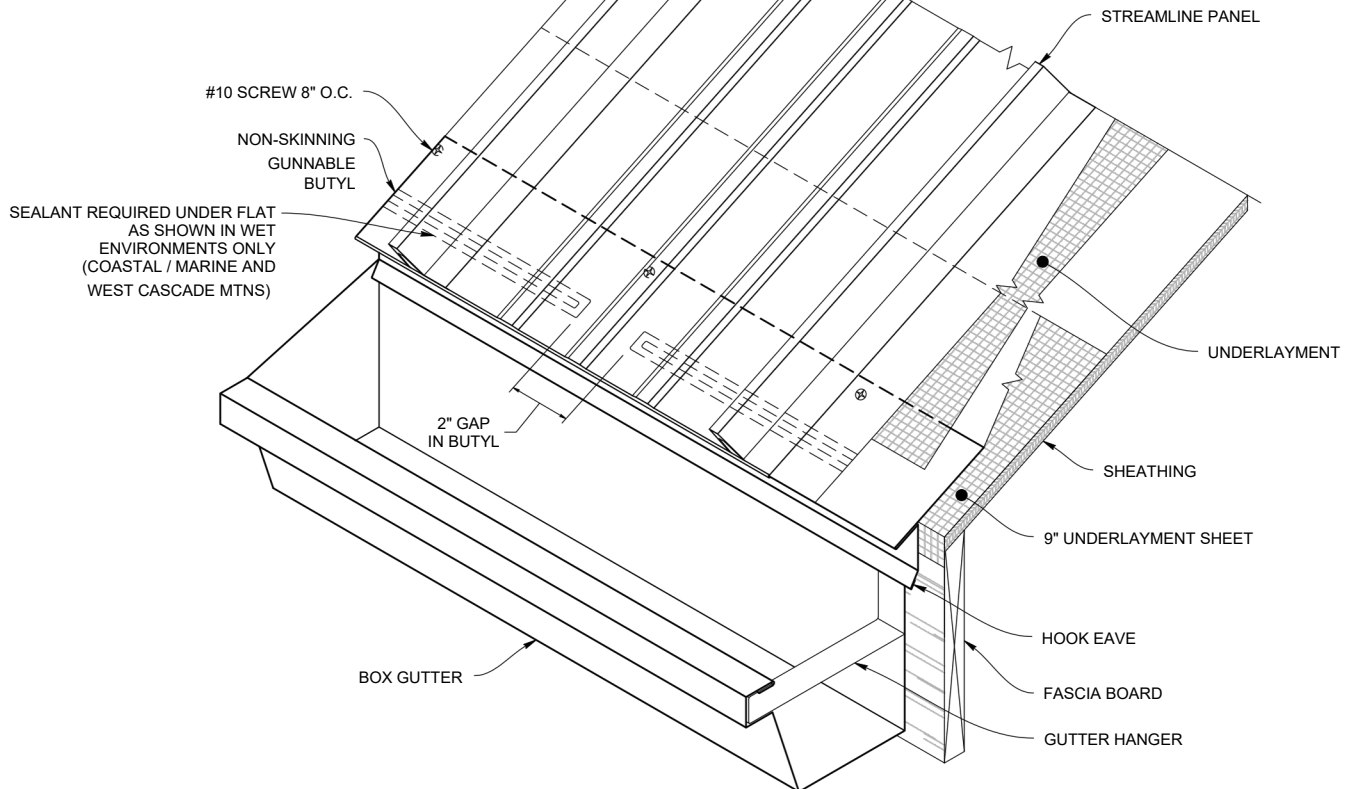
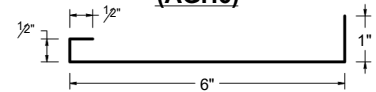

## HIP / RIDGE DETAIL

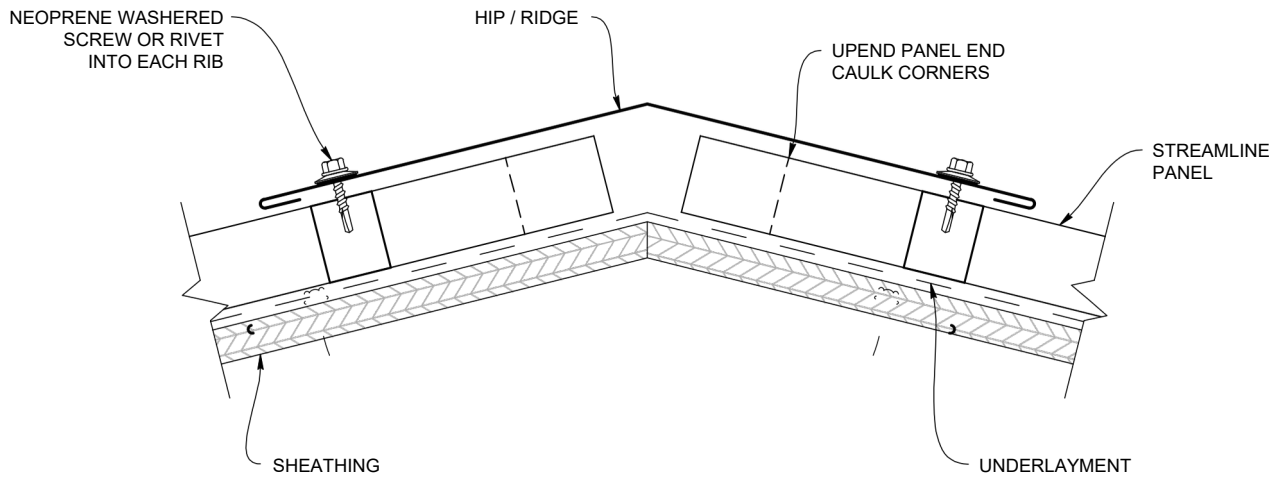

### Hip / Ridge Application

- Outstanding seam panel to match angle of hip/ridge.
- Install panels and upend; caulk the corners.
- Notch hip/ridge cap (as required) for ribs on panel(s). Notch with snips to match rib alignment.
- Allow hip/ridge cap to overhang the bottom corner at least 1-1/2".
- Box in the lower end to match angle of corner.
- Overlap hip/ridge cap, top to bottom, 2" to 3" and caulk each lap.
- Attach hip/ridge cap to each rib of panels with woodfast screw, pop rivet, or stich screw.

**Note: If ribs are over 24" apart on panel angles, use "Z" Strip for secure fastening.**

### HIP / RIDGE FLASHING (SLHR5.625)

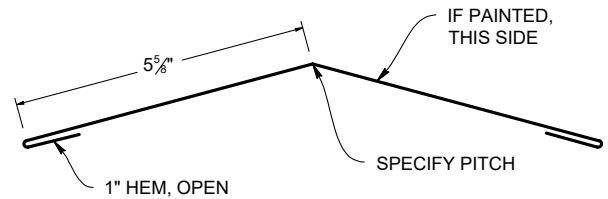

### HIP / RIDGE FLASHING (SLHR7)

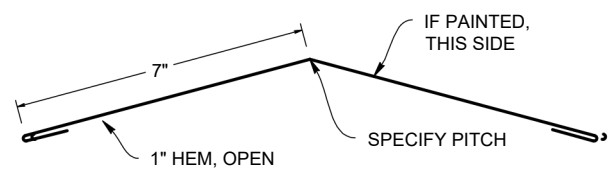

### HIP / RIDGE LAP

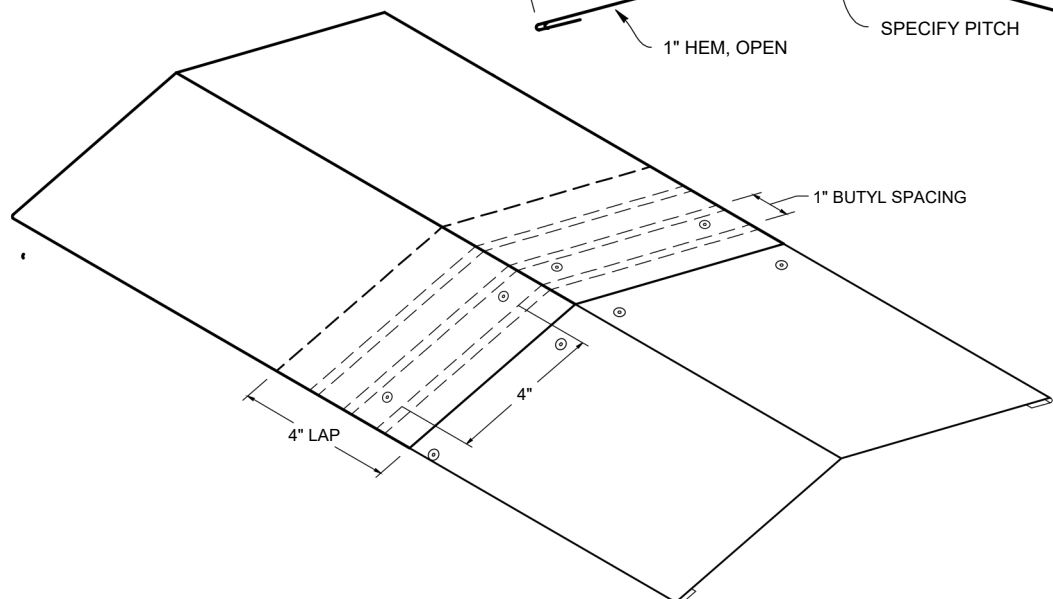

## RIDGE W/ VENTED CLOSURE DETAIL

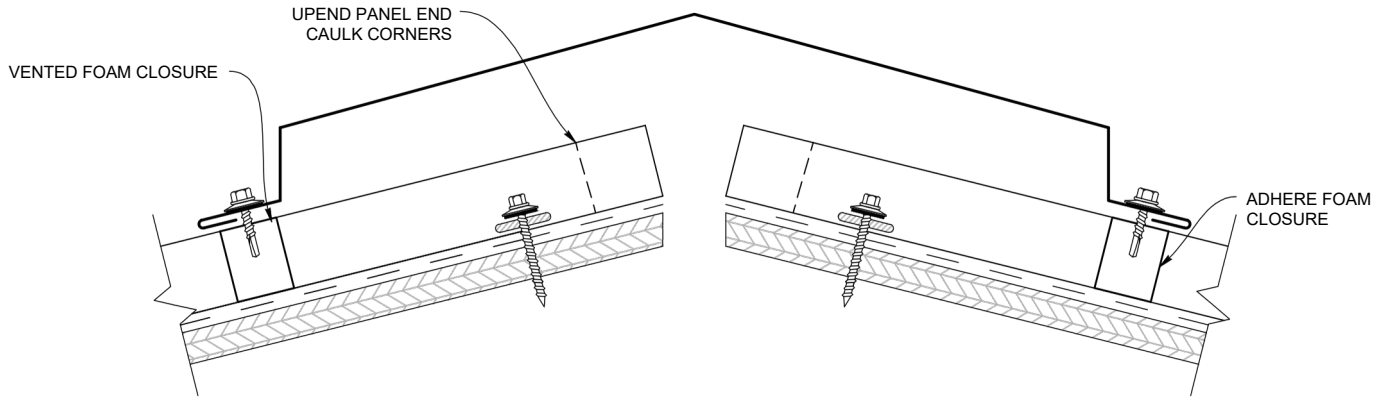

### R17 RIDGE (SLR17)

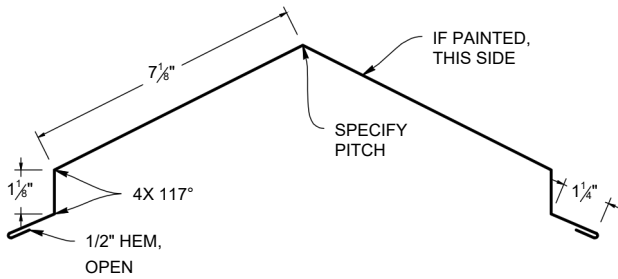

### FIELD NOTCHED RIDGE (SLRS)

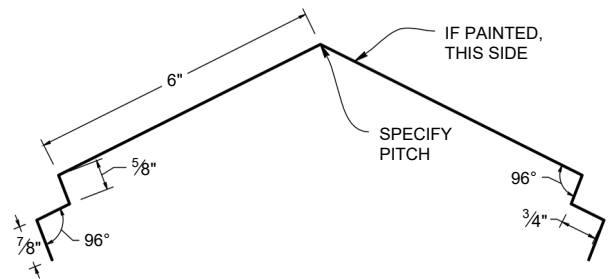

## RIDGE LAP

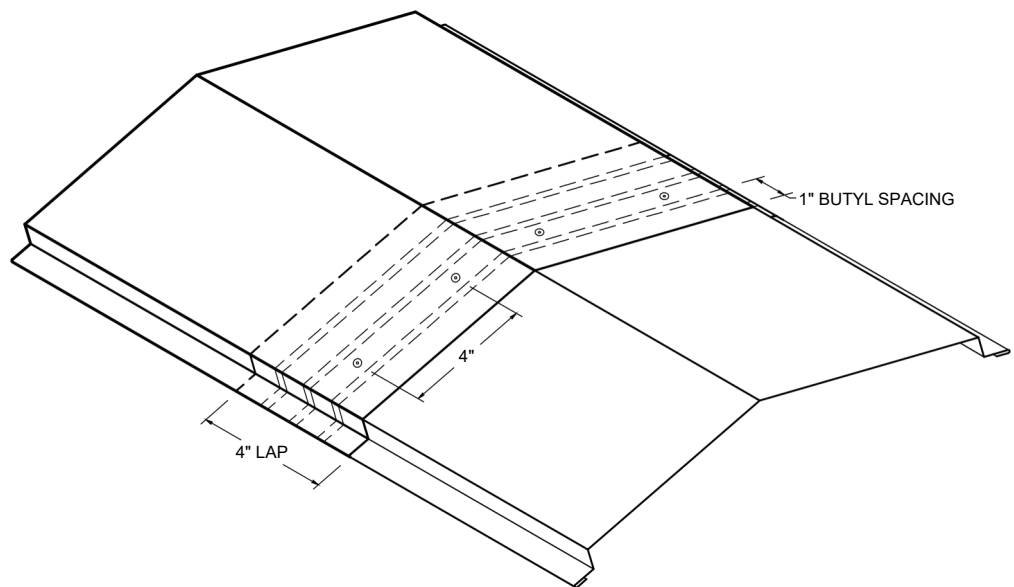

## WT RIDGE VENTED DETAIL

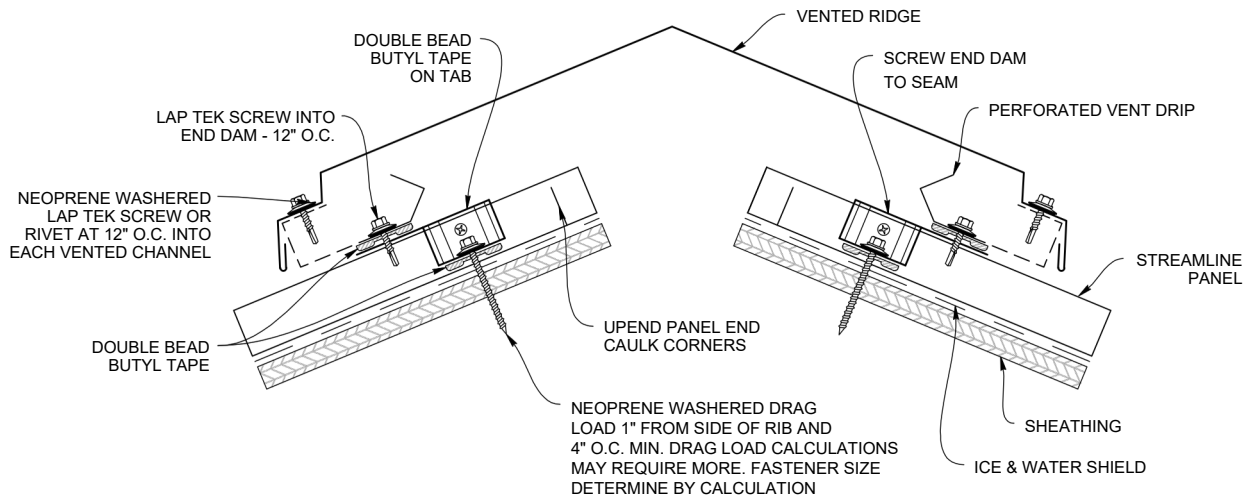

## WT RIDGE FULL VENTED (WTRFV)

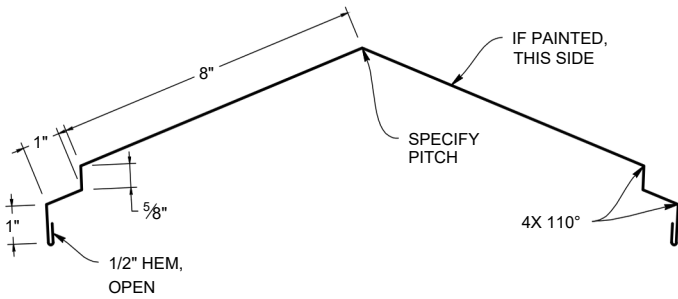

## PERFORATED VENT DRIP: E2886 EMBER RESISTANT (PVD)

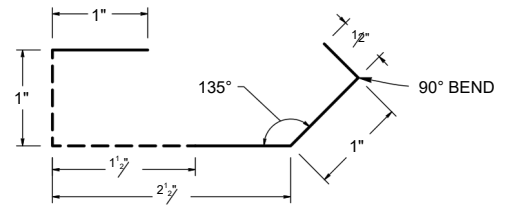

**\*\*NOTE: PERFORATED VENT DRIP IS COMPATIBLE WITH WT VENTED RIDGE ONLY\*\***

**\*\*14.5" Freeairper LFT for Ridge\*\***

## VENTED RIDGE LAP

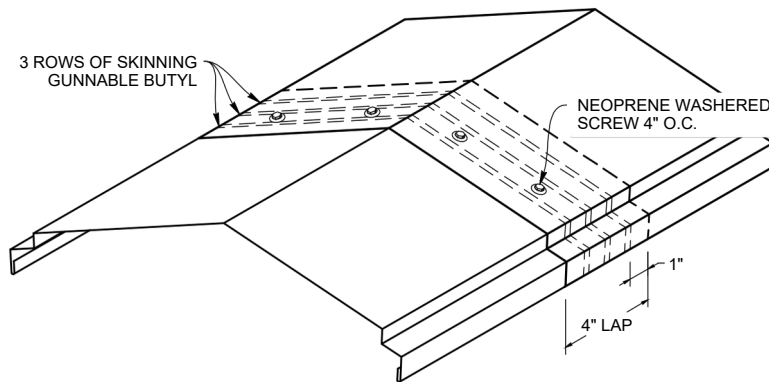

**Note:** All screws must be fastened into solid substrate.  
Flashing must be lapped 4" with 3 rows of sealant.

**STANDARD VALLEY FLASHING DETAIL**  
(3:12 or Greater Pitch)

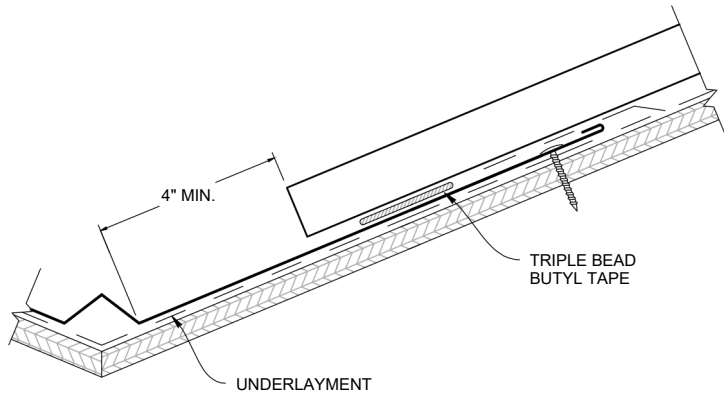

**VALLEY FLASHING (SLVF24)**

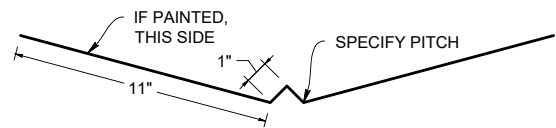

**WIDE VALLEY FLASHING (SLVFW)**

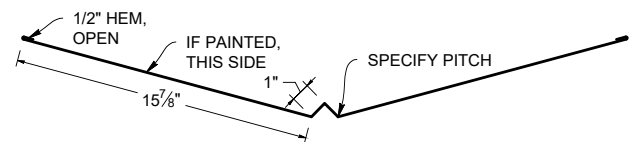

**ALTERNATE VALLEY FLASHING DETAIL**  
(Less Than 3:12 Pitch - Not Recommended)

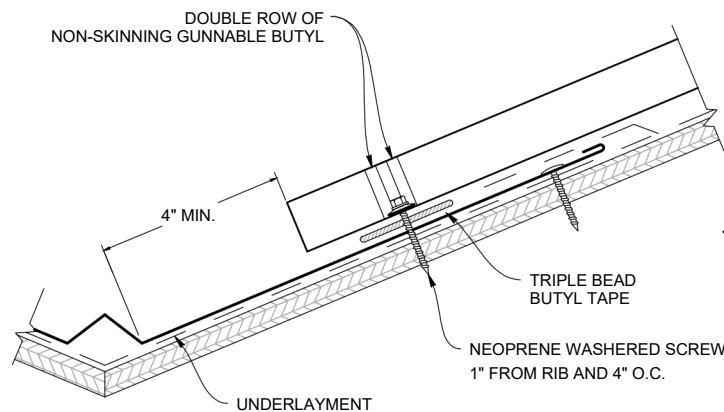

**VALLEY LAP**

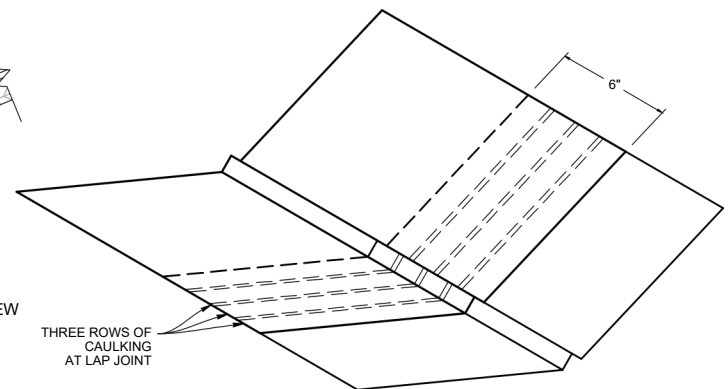

### Valley Flashing Application

- Install valley flashing by fastening through the pan as near to the outside edge (near the hem) as possible every 18" to 24" on each side. Cover fastener heads with sealant/caulking.
- Cut hems 6" back on each side of the next valley flashing. Apply three 1/4" beads of caulking between the valley pans.
- Form valley flashing over the ridge as necessary.
- Trim panels for angle of valley 4" minimum from the valley center point.
- **Note: Be sure to remove any burrs from the cut edge of panels and use a damp cloth to wipe any filings from the panel.**
- If the panels crown (pan of panel raising up) back bend panel or use the 1/2" down ending tool and bend the panel end down 30 degrees.
- Apply butyl mastic tape, or a 1/4" bead of sealant/caulking, up 1" from panel edge.
- **If using a wide valley, the panels may be set farther from the center of the valley pan, depending on climate conditions.**
- **Place butyl tape so it is 1" from end of panel.**
- **Heavy snow conditions require a wider valley pan. Leave more space between the end of the valley panels and the valley center line.**
- Consider using wide valley flashings for low pitch roofs.
- Apply a bead of sealant/caulking on top of the hems of the valley flashing.
- For standard valley install panels being sure to fasten panels through the fastening flange into substrate, as close as possible to hemmed edge of valley flashing. Do not penetrate the valley flashing with panel screws.

## BOX GABLE DETAIL

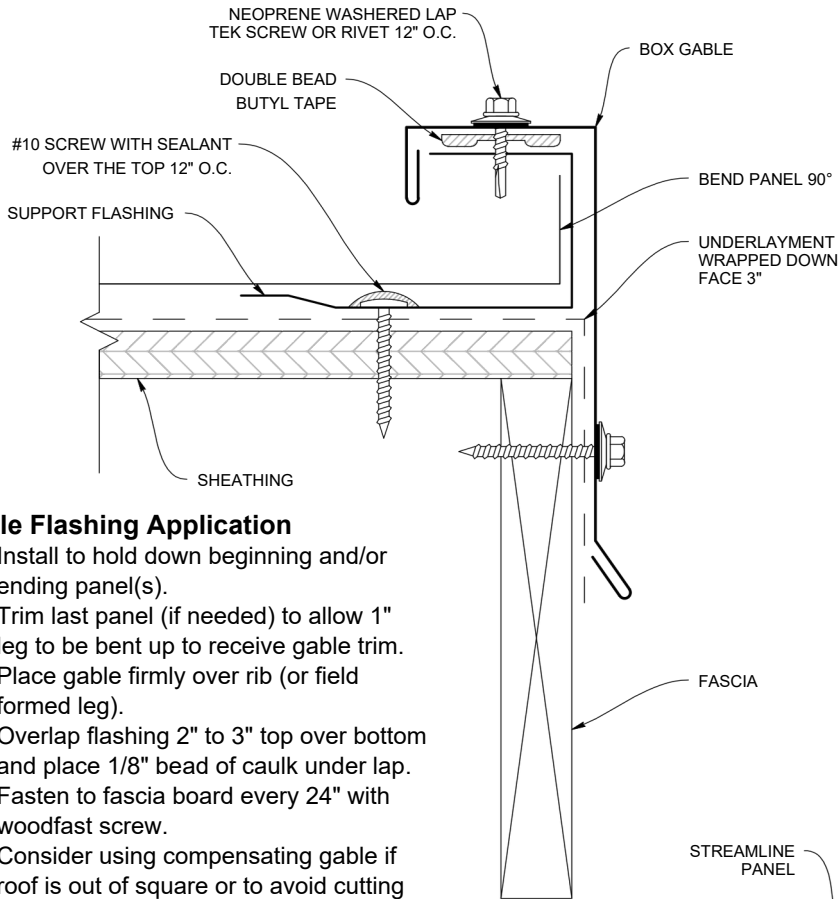

## BOX GABLE (SLGB)

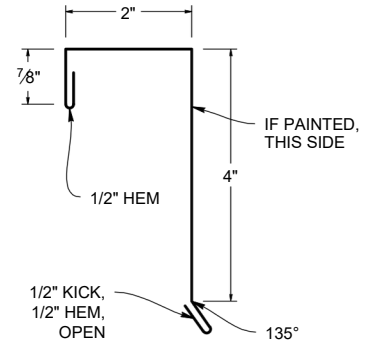

## SUPPORT FLASHING (SLSF)

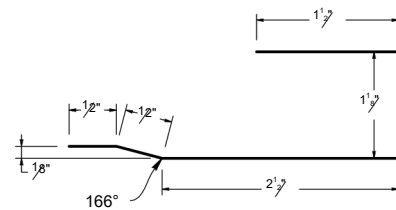

### Gable Flashing Application

- Install to hold down beginning and/or ending panel(s).
- Trim last panel (if needed) to allow 1" leg to be bent up to receive gable trim.
- Place gable firmly over rib (or field formed leg).
- Overlap flashing 2" to 3" top over bottom and place 1/8" bead of caulk under lap.
- Fasten to fascia board every 24" with woodfast screw.
- Consider using compensating gable if roof is out of square or to avoid cutting very narrow panel for the ending panel.
- Compensating gable flashing will allow installation to begin or end up to 2" from gable edge.

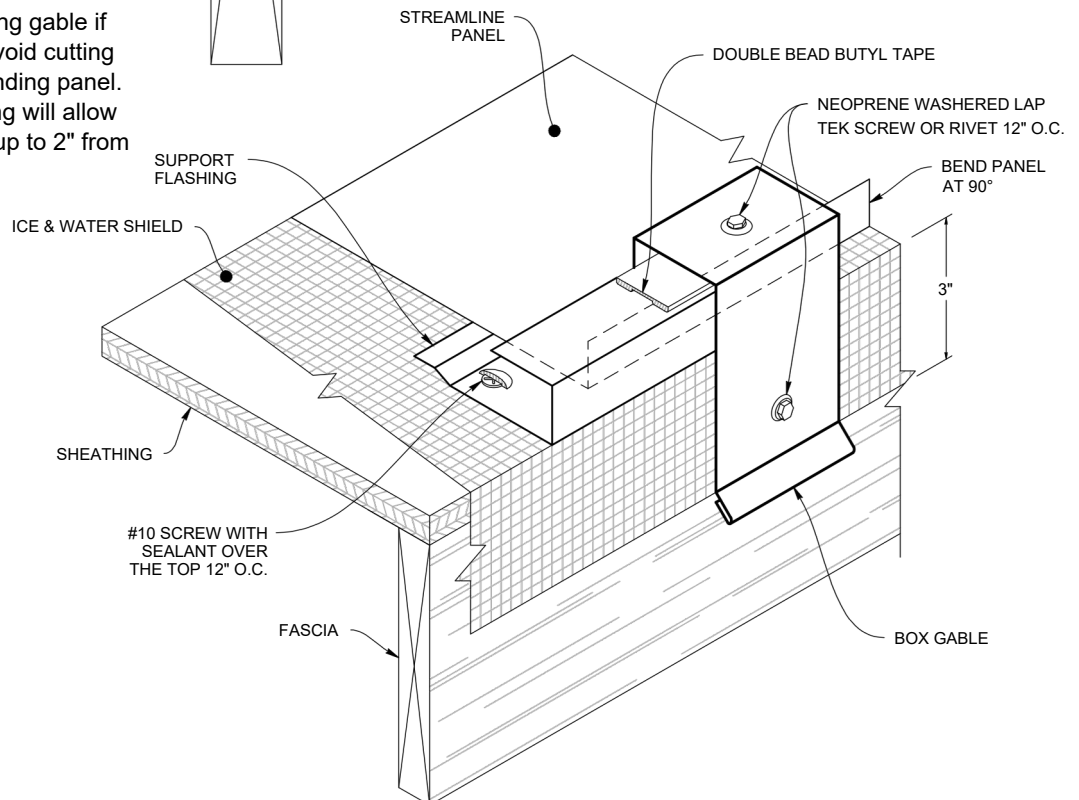

## ALTERNATE GABLE DETAIL

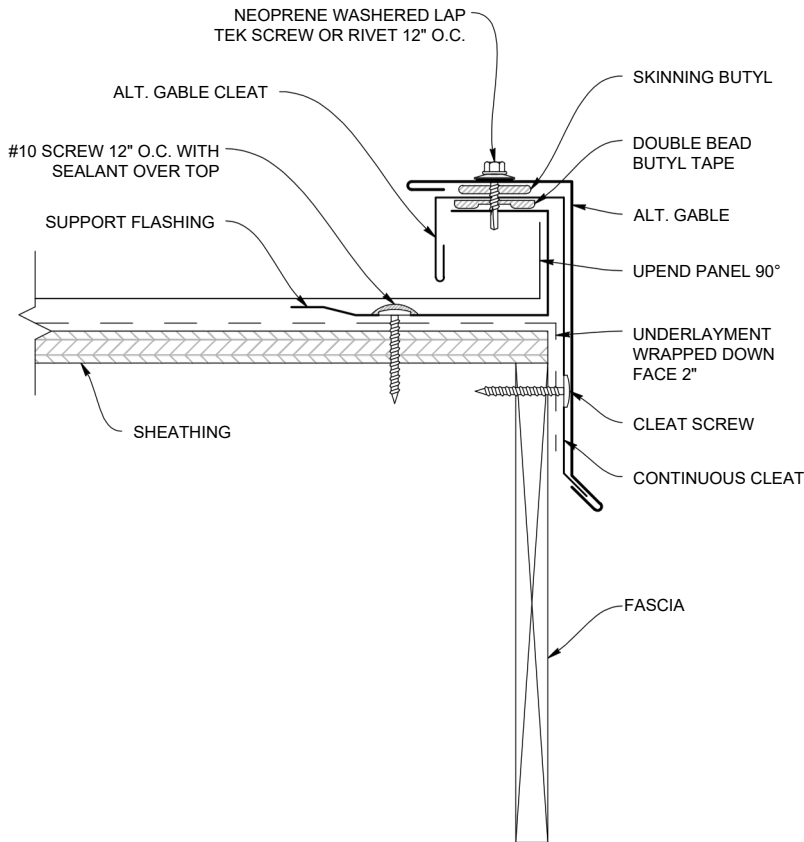

## ALTERNATE GABLE (SLAG)

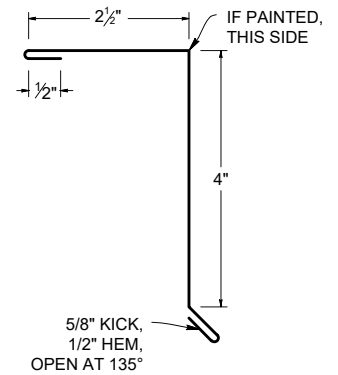

## SUPPORT FLASHING (SLSF)

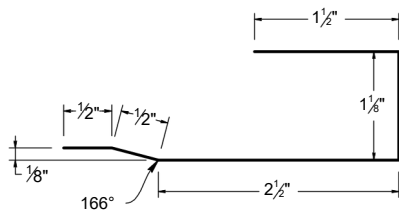

## ALTERNATE GABLE CLEAT (SLAGT)

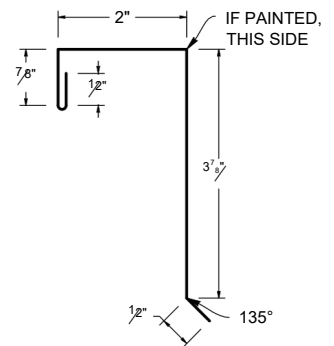

## PROW DETAIL

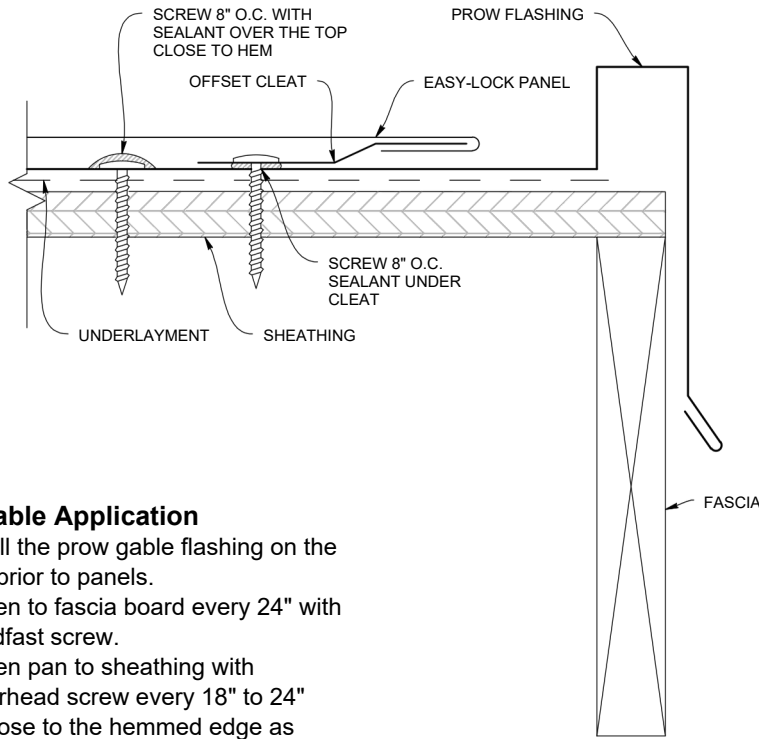

## PROW FLASHING (SLPF)

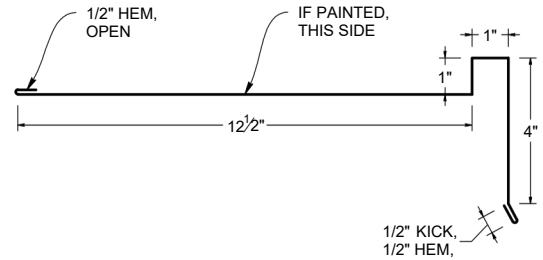

## OFFSET CLEAT (SLOC)

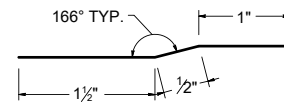

### Prow Gable Application

- Install the prow gable flashing on the roof prior to panels.
- Fasten to fascia board every 24" with woodfast screw.
- Fasten pan to sheathing with waferhead screw every 18" to 24" as close to the hemmed edge as possible. Cover screw heads with sealant/caulking.
- Trim panels to angle of prow, 2" from the edge of the raised portion of the flashing.

**Note: Be sure to remove any burrs on the cut edge of the panel and use a damp cloth to wipe any filings from the panel.**

- Apply butyl tape or 1/4" bead of sealant/caulking 3" from the raised edge of the prow flashing, (1" under end of panels). Apply a 1/4" bead of sealant/caulking to the top of the hem of the prow flashing. Fasten the panels as close to the hemmed edge of the prow flashing as possible. Due to the long cuts typical of the angle of the prow, using the 1/2" upending tool, bend the cut edge down 30 degrees or turn the edge under forming a hem.

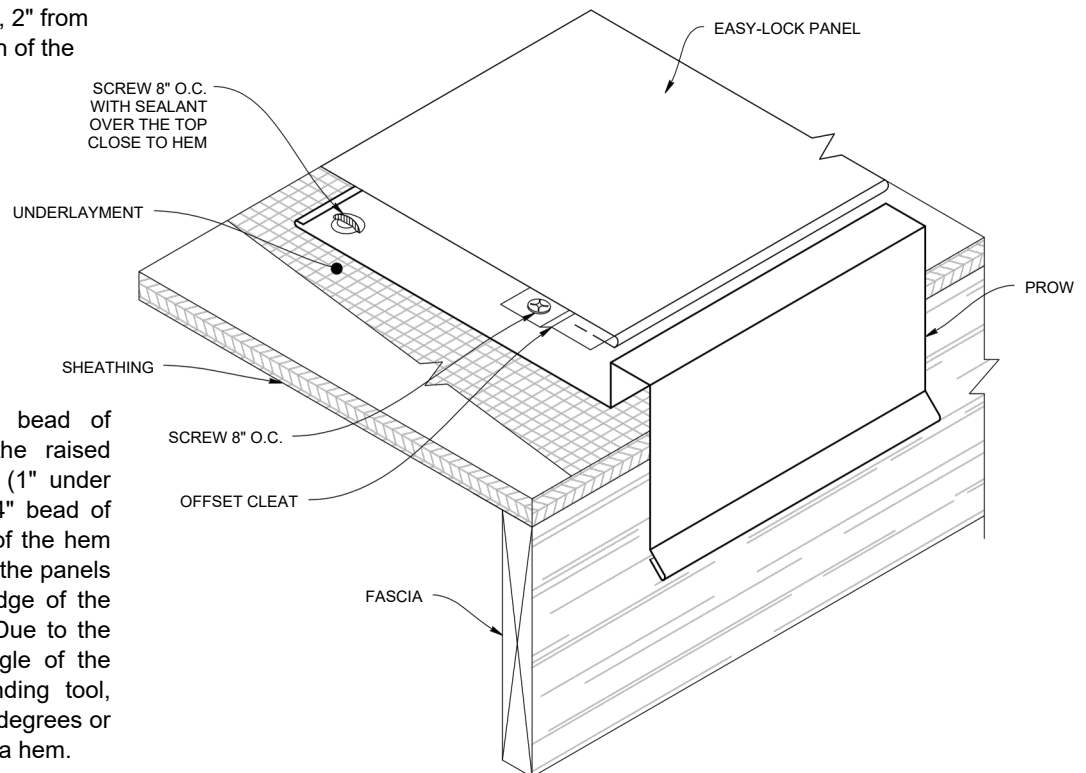

## SIDEWALL DETAIL

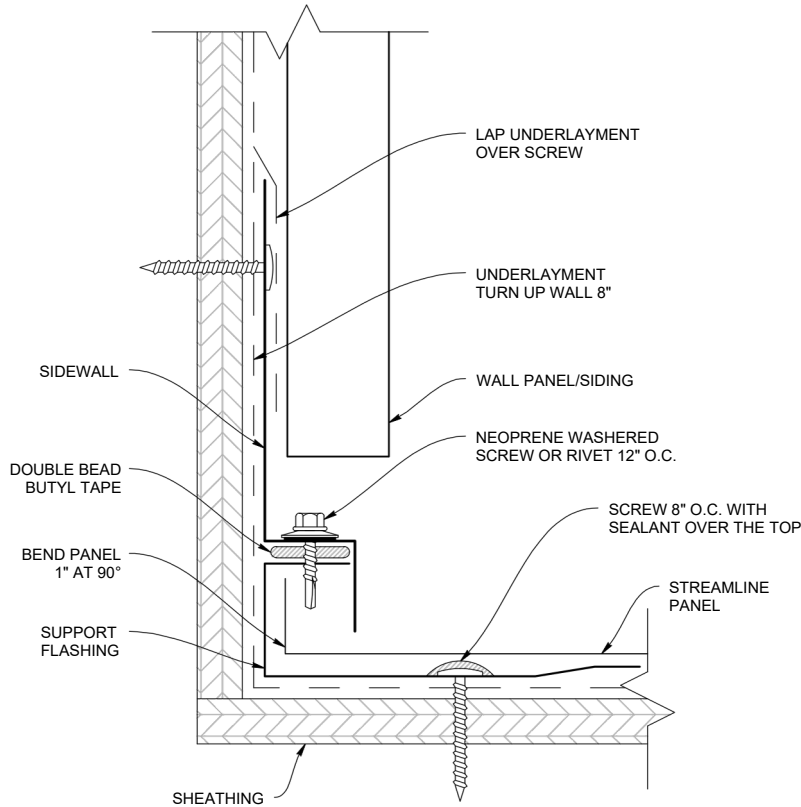

## SIDEWALL & COMPENSATING SIDEWALL (SLSW) (SLSWC)

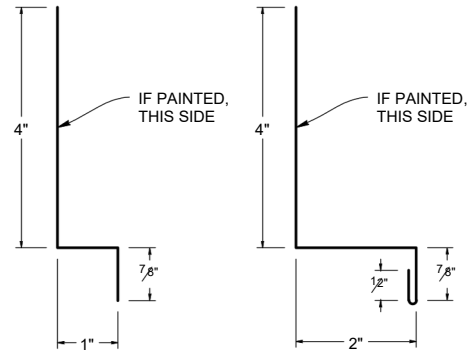

## SUPPORT FLASHING (SLSF)

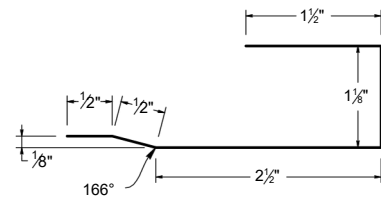

### Sidewall Application

- Sidewall flashing is used where wall runs parallel with slope.
- Install roofing panel first.
- Flash over rib if starting panels at wall or over upended edge of panel (pictured).
- Install flashing under siding (pictured). Attach to wall with waferhead screw for this option. **OPTION:** Siding is cut 1/4" deep and lip is caulked into the cut to seal. Attach to wall with woodfast screw every 24".

**Note: Specify with lipifusing**

**this method of installation.**

- Overlap flashing end to end 2" to 3" and caulk at lap.

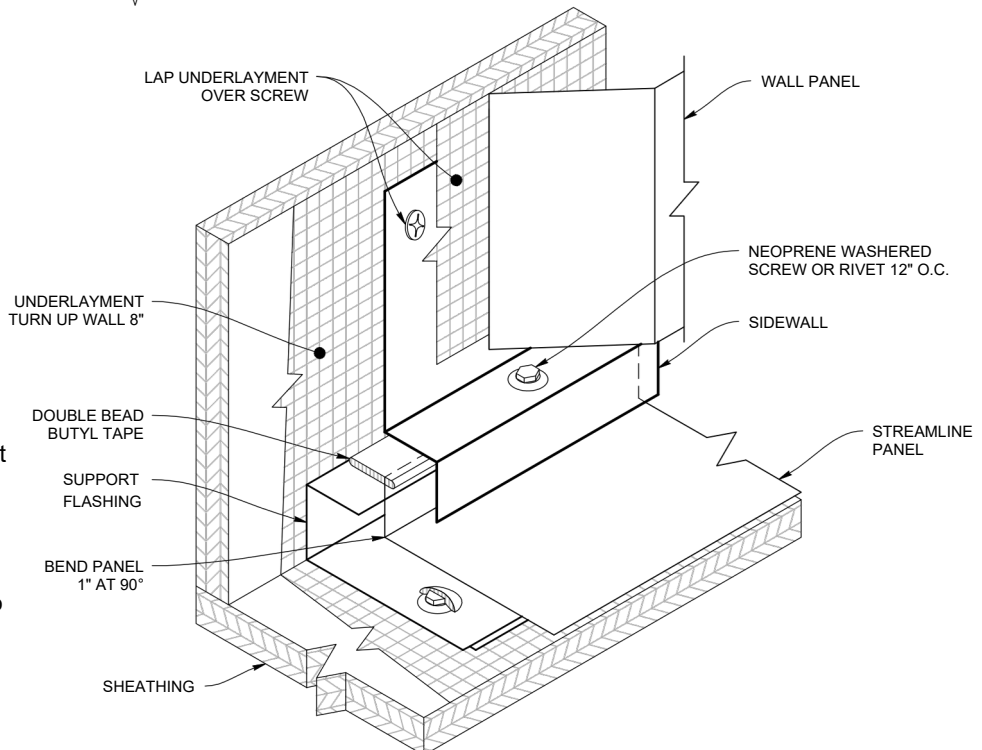

### PEAK FLASHING DETAIL (RIDGE END CAP)

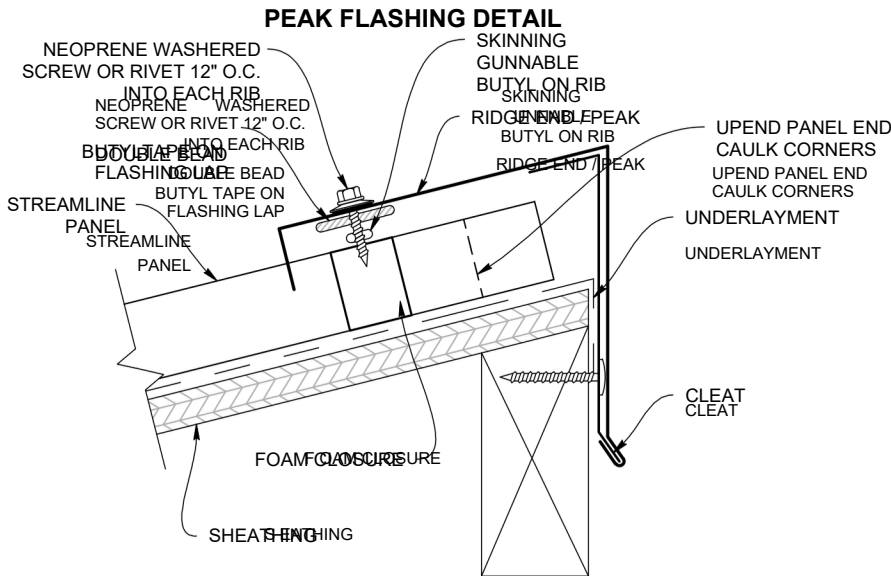

### FIELD NOTCHED PEAK FLASHING (SLREC)

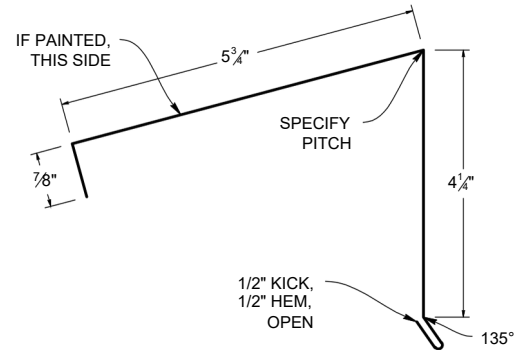

### PEAK CLEAT (SLRECC)

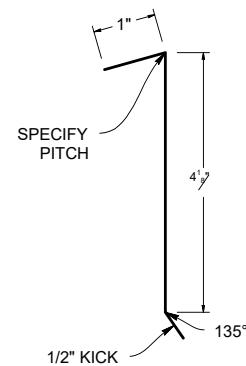

### Peak Flashing (Ridge End Cap) Application

- Notch 1" leg to fit over rib of panel.
- Fasten through peak flashing into ribs of panel every 24" with woodfast screw or rivet.
- Fasten through 4-3/4" leg of peak flashing into fascia board every 24" with woodfast screw.
- Overlap flashing end to end 2" to 3". Place 1/4" bead of caulk under lap.
- Fasten peak flashing at lap with rivet or woodfast screw.

### PEAK LAP

#### HEMMED PEAK FLASHING (SLRECH)

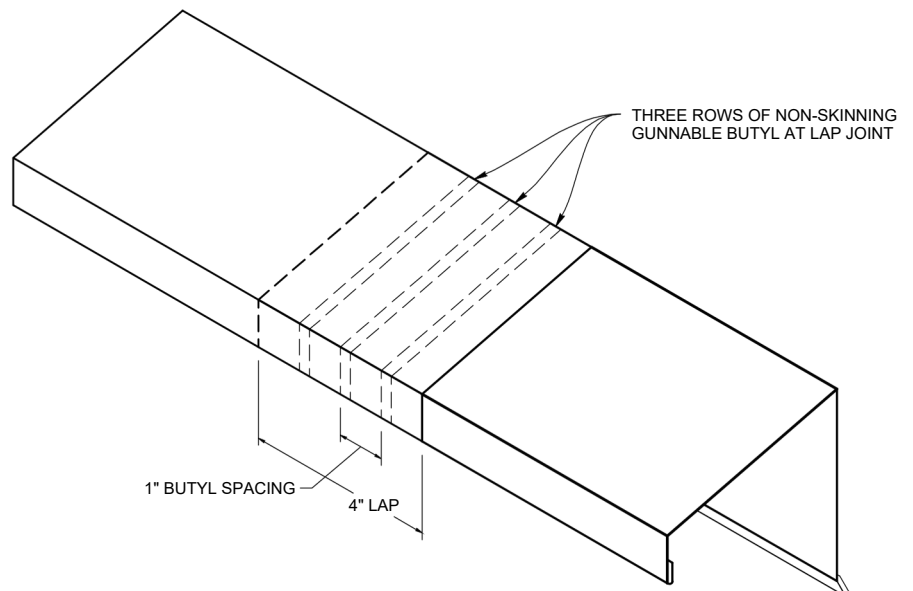
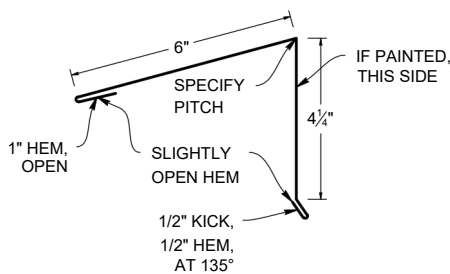

## PITCH CHANGE DETAIL

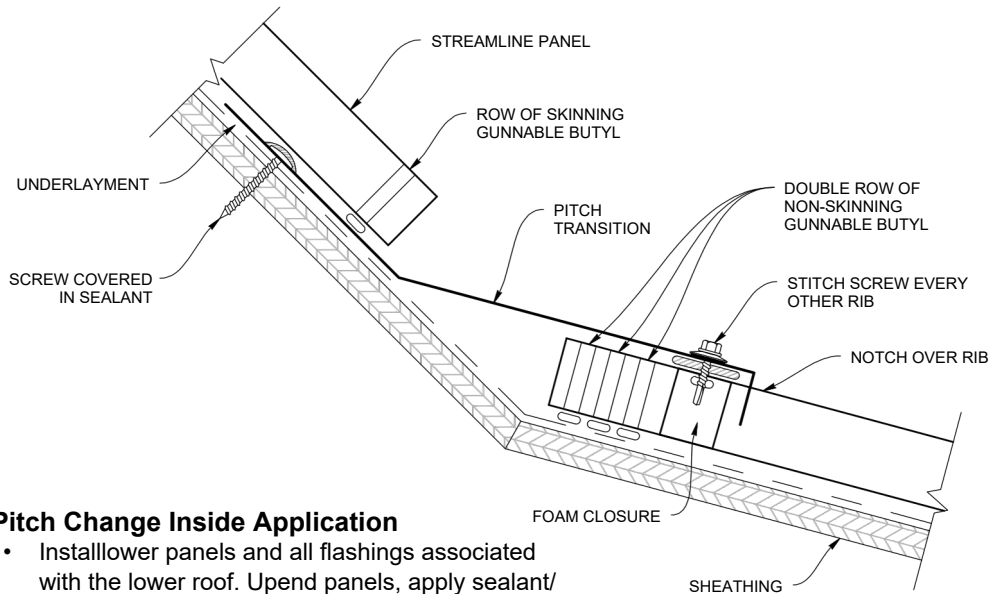

## INSIDE PITCH CHANGE (SLPCIN)

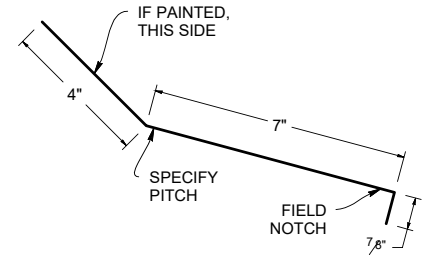

### Pitch Change Inside Application

- Install lower panels and all flashings associated with the lower roof. Upend panels, apply sealant/caulking to corners of up-ended pan.
- Notch 1" leg of flashing to fit over rib of panels.
- Attach upper leg of flashing to sheathing with a waferhead screw on the upper leg every 18" to 24" or as needed. Place sealant/caulking on screw head.
- Allow 3" overlap on flashing, apply three 1/4" beads of sealant/caulking under lap.
- Attach lower leg of flashing to every other rib, with a woodfast screw, rivet or stitch screw.
- Place a 1/4" bead of sealant/caulking on the upper leg of the flashing 1-1/2" from the break.
- Install the panels 1/2" from the break.

**Note: Custom flashings may be required**

**when pitches are close, e.g. 3:12 to 1:12.**

## PITCH CHANGE LAP

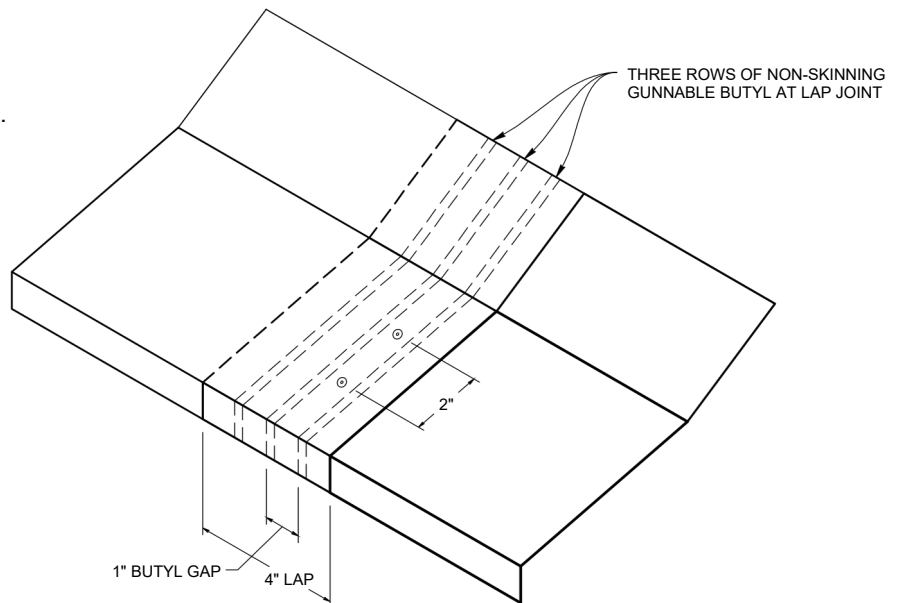

## WT VENTED PEAK FLASHING DETAIL (Vented Ridge End Cap)

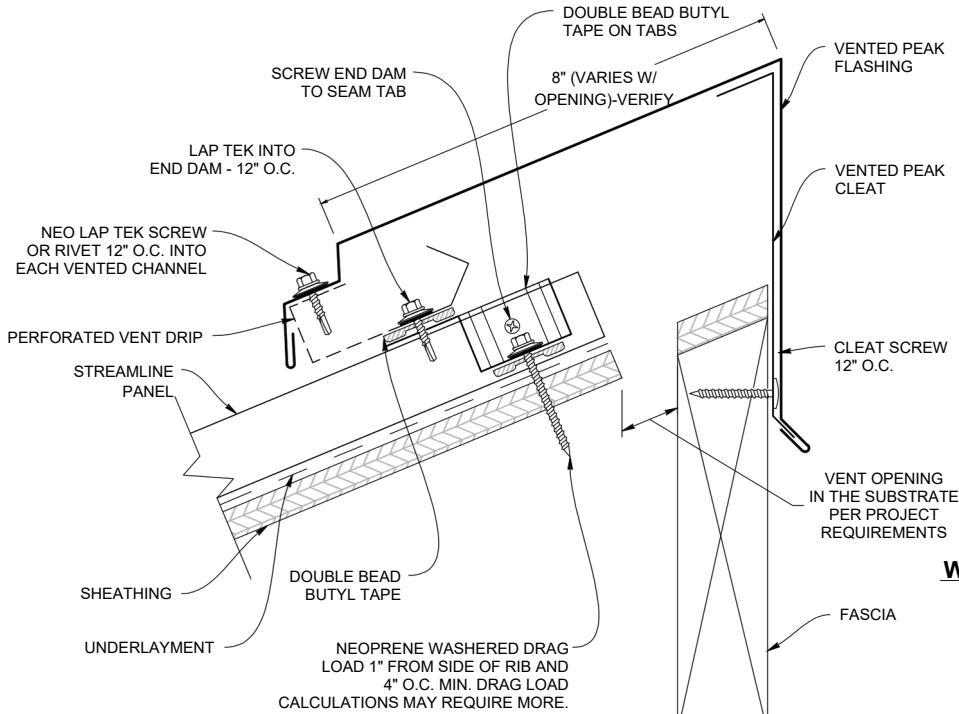

## VENTED PEAK CLEAT (VRECC)

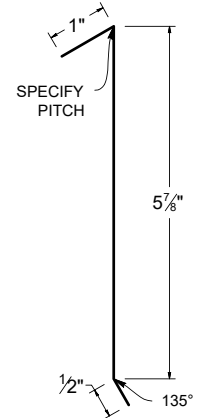

## WT VENTED PEAK FLASHING (WTRECV)

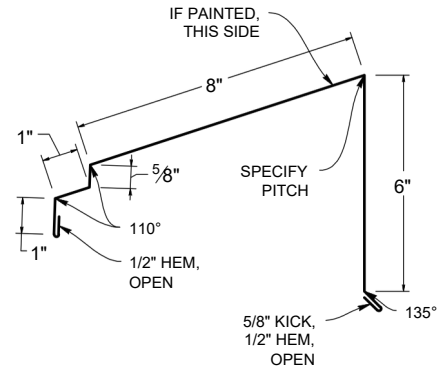

## VENTED PEAK FLASHING LAP

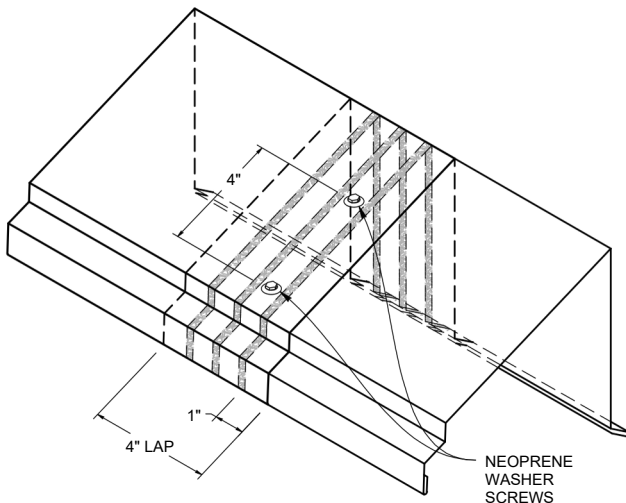

## PERFORATED VENT DRIP : E2886 EMBER RESISTANT (PVD)

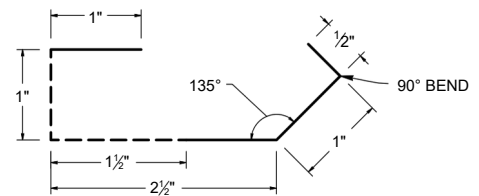

**\*\*NOTE: PERFORATED VENT DRIP IS COMPATIBLE WITH WT VENTED PEAK FLASHING ONLY\*\***

**\*\*7.25" Freeairper LFT for Ridge\*\***

**Note:** All screws must be fastened into solid substrate. Flashing must be lapped 4" with 3 rows of sealant.

## HEMMED ENDWALL DETAIL

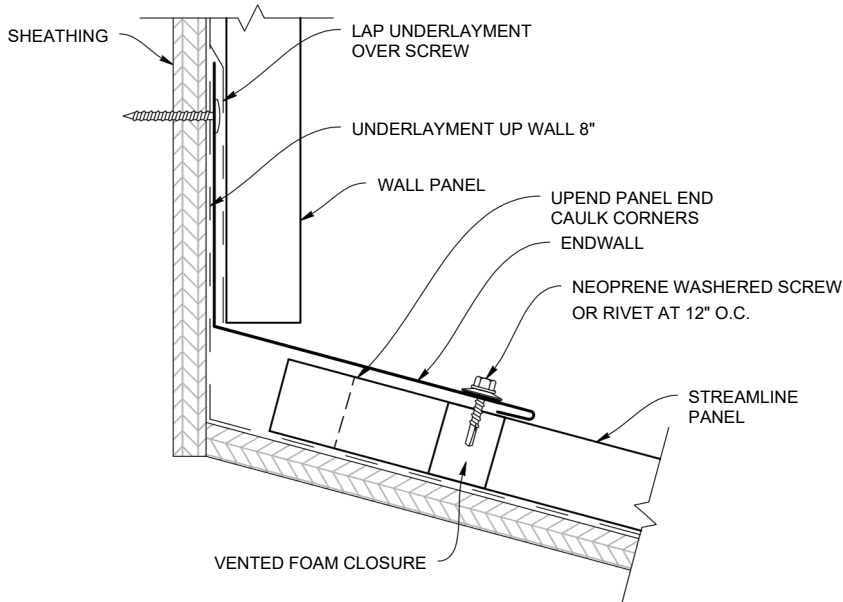

## HEMMED ENDWALL FLASHING (SLEWH)

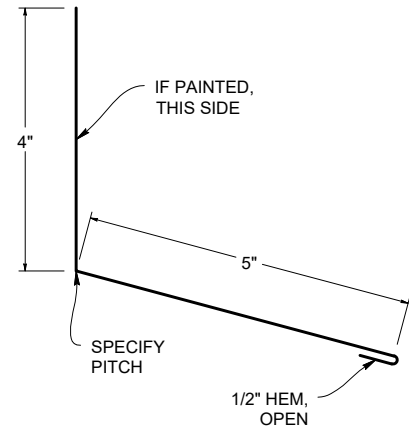

### Endwall Application

- Endwall flashing is used where the roof slopes away from a wall (i.e., clerestory or shed roof.) Up-end top of panel and apply sealants/ caulking to the corner of the up-ended pans before installing flashing. Notch 1" leg of endwall to fit over ribs of panels. Upper leg (2- 1/2") is placed under siding. **OPTION:** Siding is cut 1/4" deep and the lip is caulked into the cut to seal. **Note: Specify with lip if using this method of installation.**
- Attach flashing to every other rib of panel with rivet, woodfast screw or stitch screw. Overlap flashing end to end 2" to 3". Place 1/4" bead of sealant/caulking under lap.

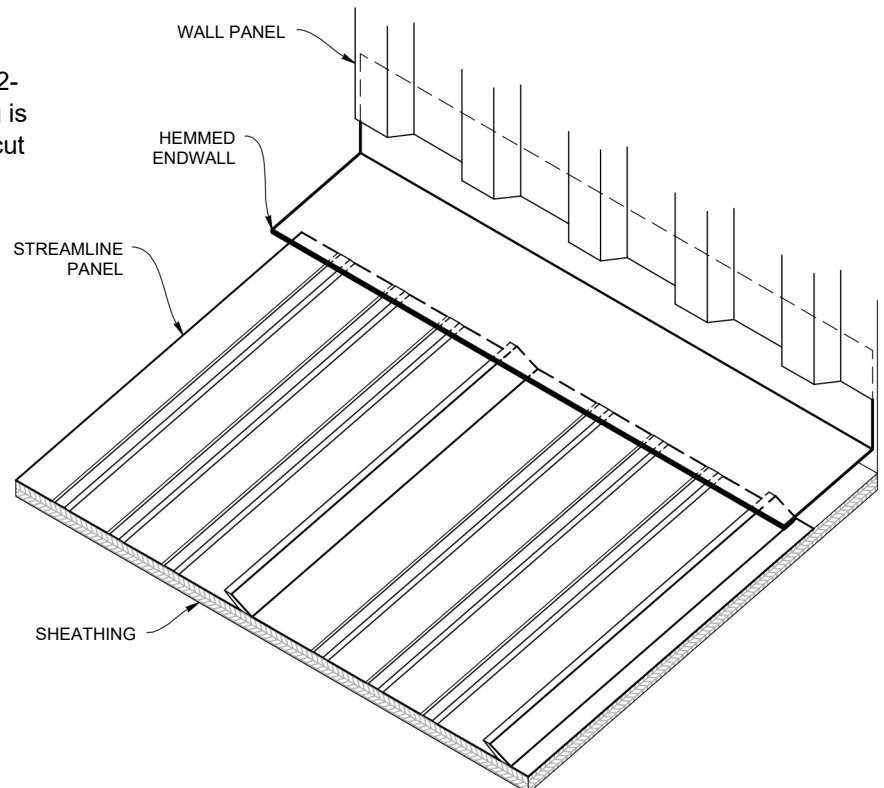

## Vented Endwall Plan Details

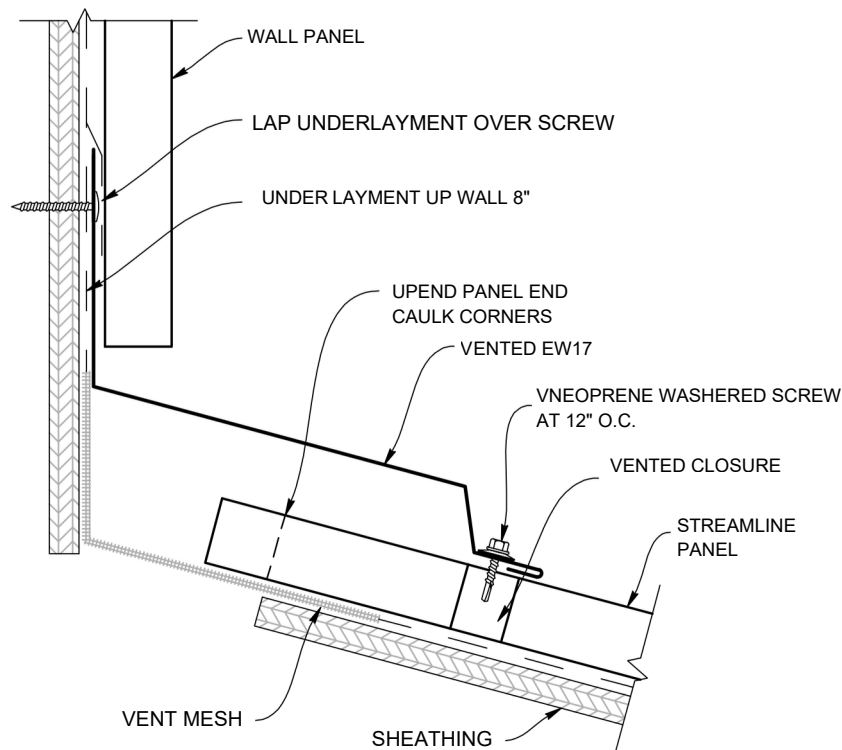

## EW17 ENDWALL FLASHING (SLEW17)

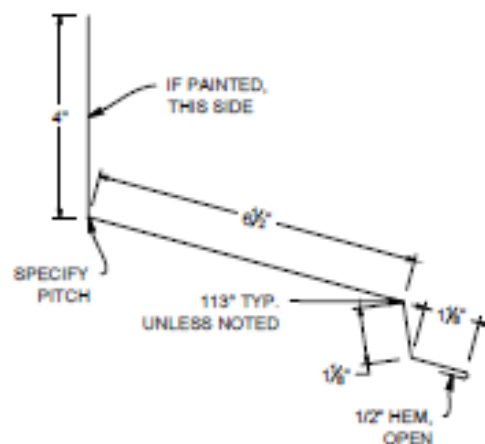

## ENDWALL LAP

### Vented Endwall Application

- Vented endwall flashing is used to provide ventilation at the wall. Cut out or leave the sheathing back 2" from the wall and cover with vent mesh/flyscreen.
- Upend top of panel and caulk the corners before installing the flashing.
- Place the vented endwall flashing on top of the ribs of the panels. The upper leg (2-1/2") is placed under the siding.
- OPTION: Siding is cut 1/4" deep and the lip is caulked into the cut to seal.
- Note: Specify with lip if using this method of installation.
- Attach flashing to every other rib of panel with rivet, woodfast screw or stitch screw.
- Overlap flashing end to end 2" to 3". Place 1/4" bead of sealant/caulk under lap.

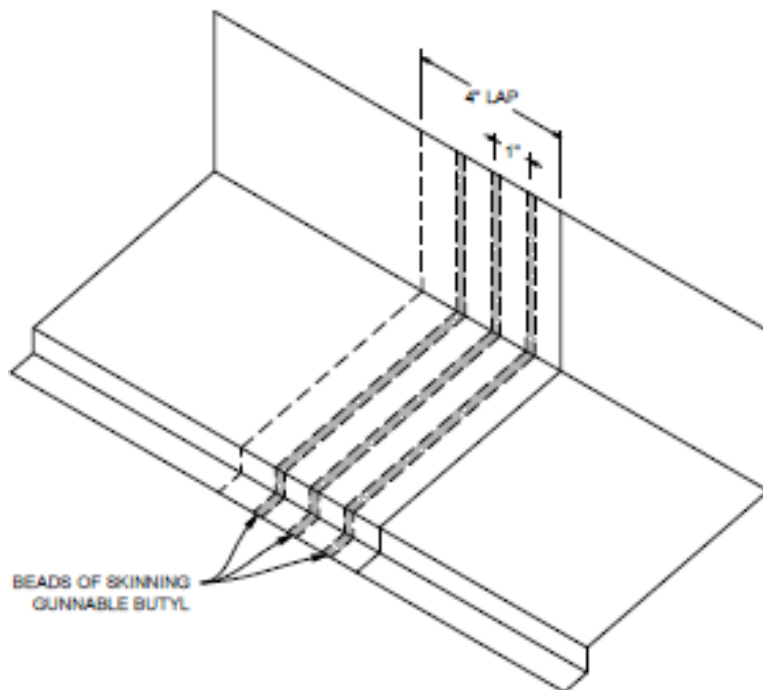

## WT VENTED ENDWALL DETAIL

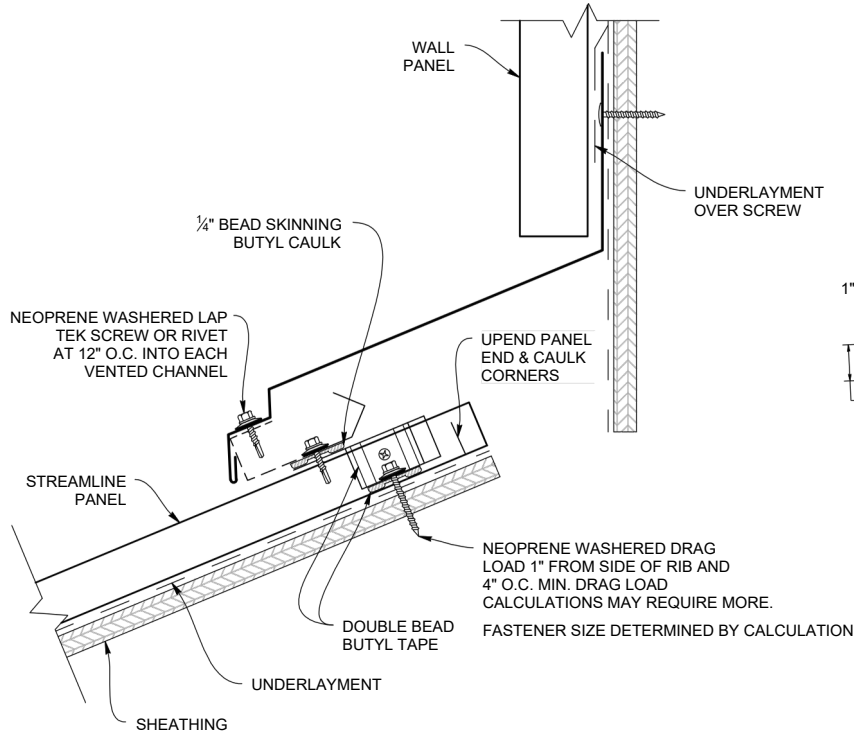

## VENTED ENDWALL LAP

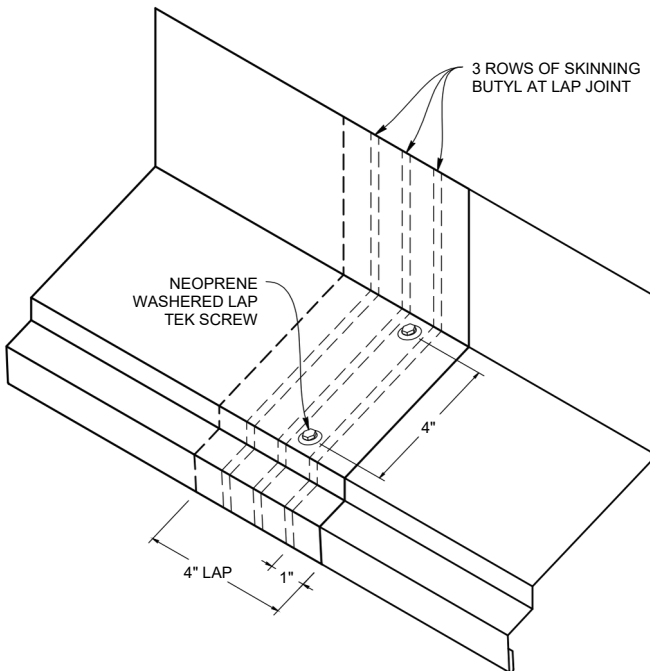

## WT VENTED ENDWALL FLASHING (WTEWV)

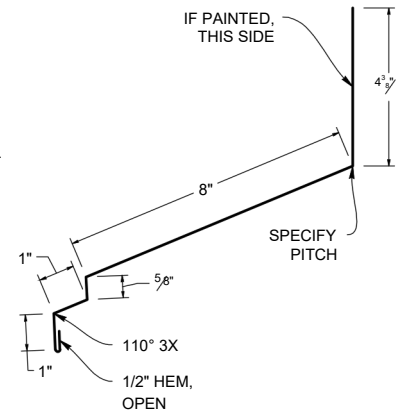

## PERFORATED VENT DRIP: E2886 EMBER RESISTANT (PVD)

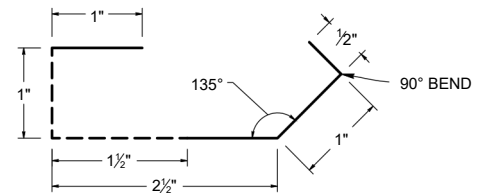

**\*\*NOTE: PERFORATED VENT DRIP IS COMPATIBLE WITH WT VENTED ENDWALL ONLY\*\***

**\*\*7.25" Freeairper LFT for Ridge\*\***

**Note:** All screws must be fastened into solid substrate.  
Flashing must be lapped 4" with 3 rows of gunnable sealant.

## EAVE TO GABLE TRANSITION

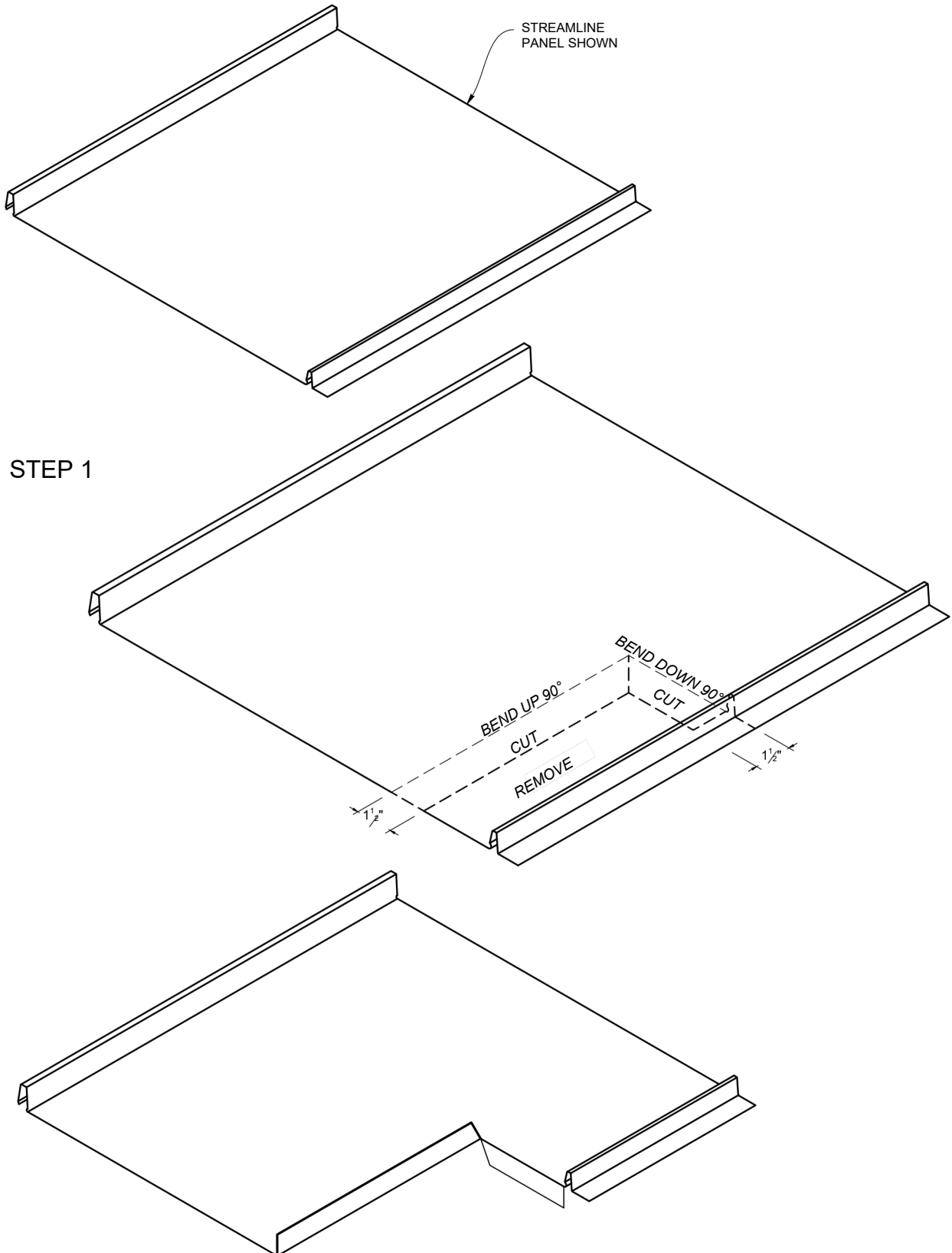

## STEP 2

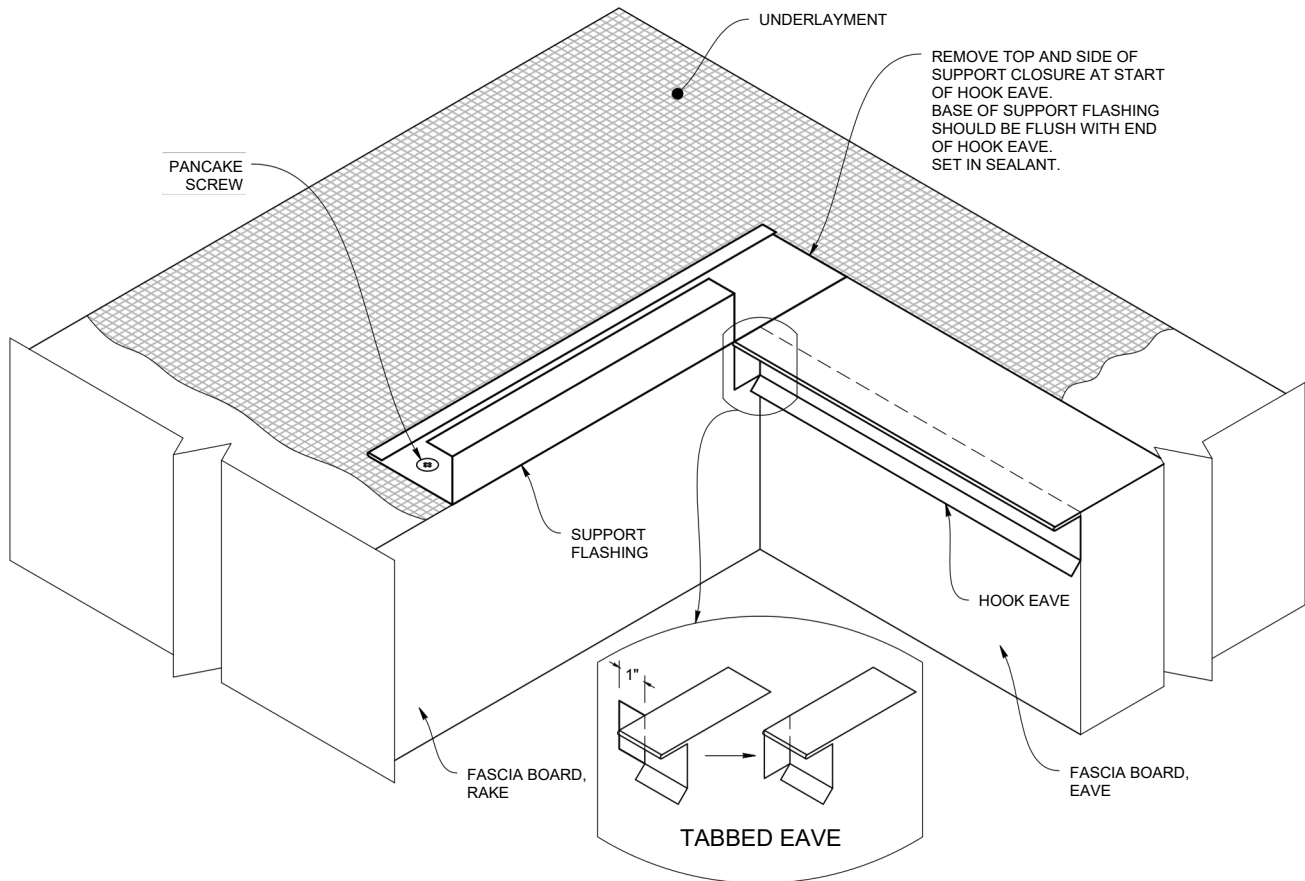

## STEP 3

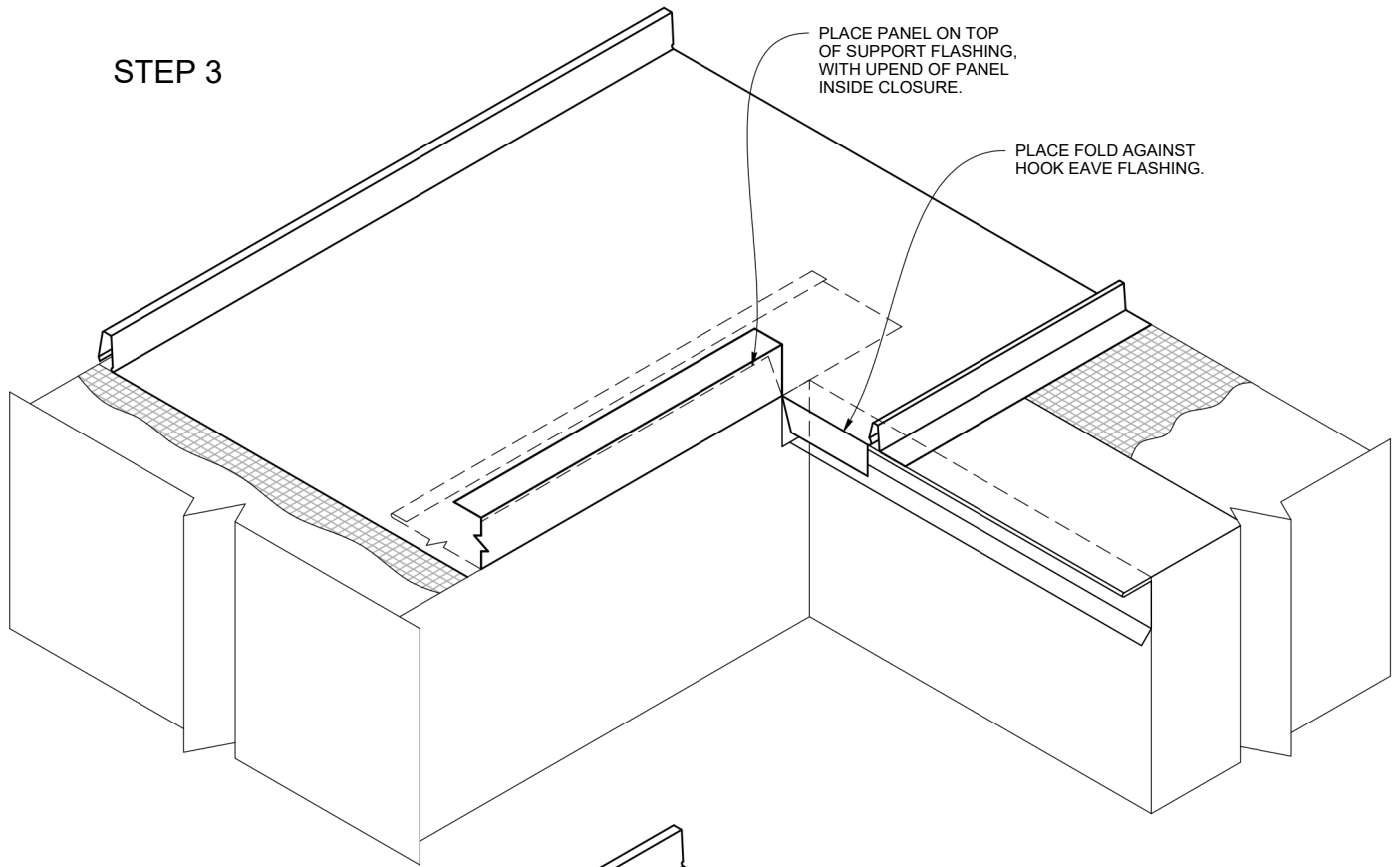

## STEP 4

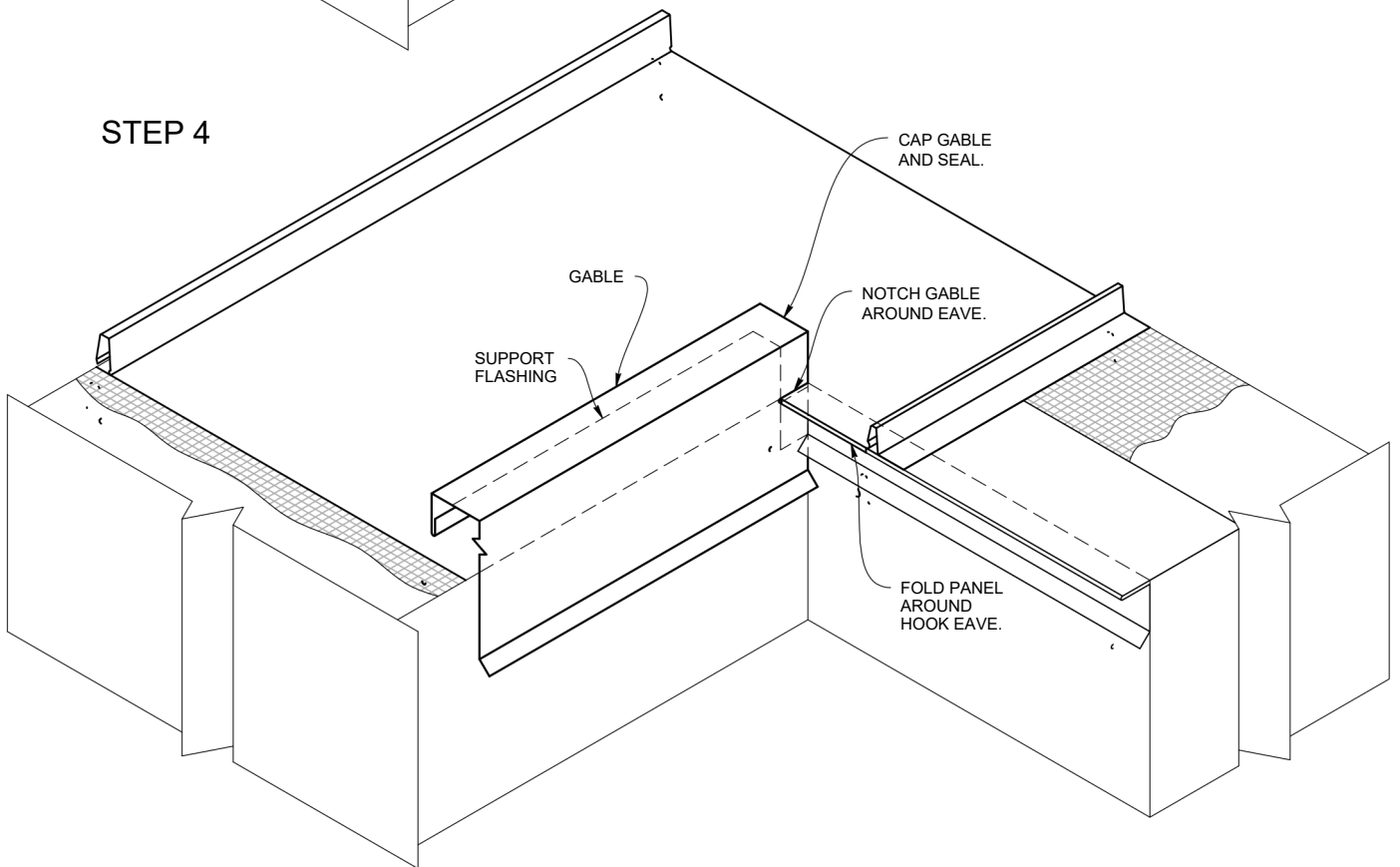

## SKYLIGHT / CHIMNEY TRIM

### For 2" X 4" Curbing

### For 2" X 6" Curbing

3-1/2" PAN FLASHING (SLP3)

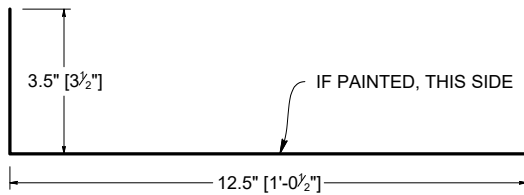

5-1/2" PAN FLASHING (SLP5)

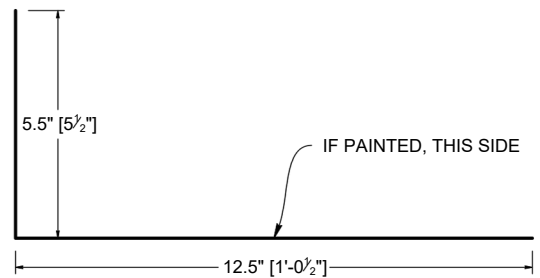

2-1/2" SIDE AND BOTTOM FLASHING (SLSB3)

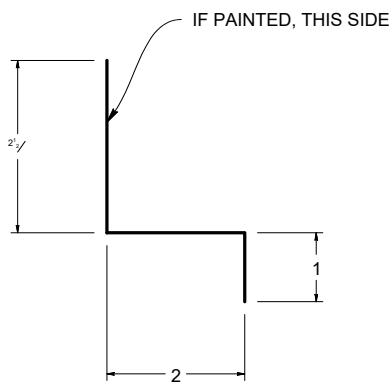

5-1/2" SIDE AND BOTTOM FLASHING (SLSB5)

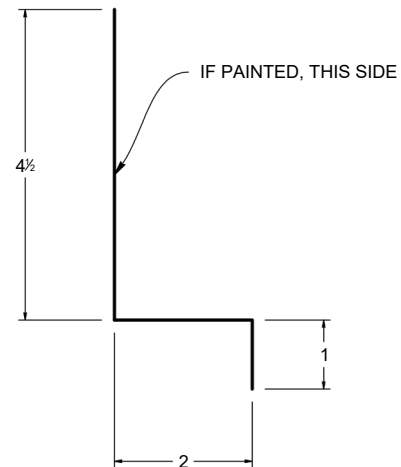

Apply parts as described on the following pages. Please note that the 12-inch leg of the pan flashing used on a chimney application will need to be bent to the pitch of the roof.

The following instructions are applicable to most typical skylight or chimney applications. However, your individual application may be unique and require custom flashing and/or special installation. Be sure to check with the skylight manufacturer to determine recommended flashing and whether deviation will result in nullifying your warranty. The use of a cricket is advised in some situations, especially where the drainage is into a curb that exceeds 2'6", or if the roof area will have a lot of debris falling on it. Crickets are specially made to fit the curb/chimney and are used in place of the pan/head flashing. Installation information for the cricket and the pan/head flashing is the same.

## SKYLIGHT / CHIMNEY APPLICATION

*Dotted lines show where to cut.*

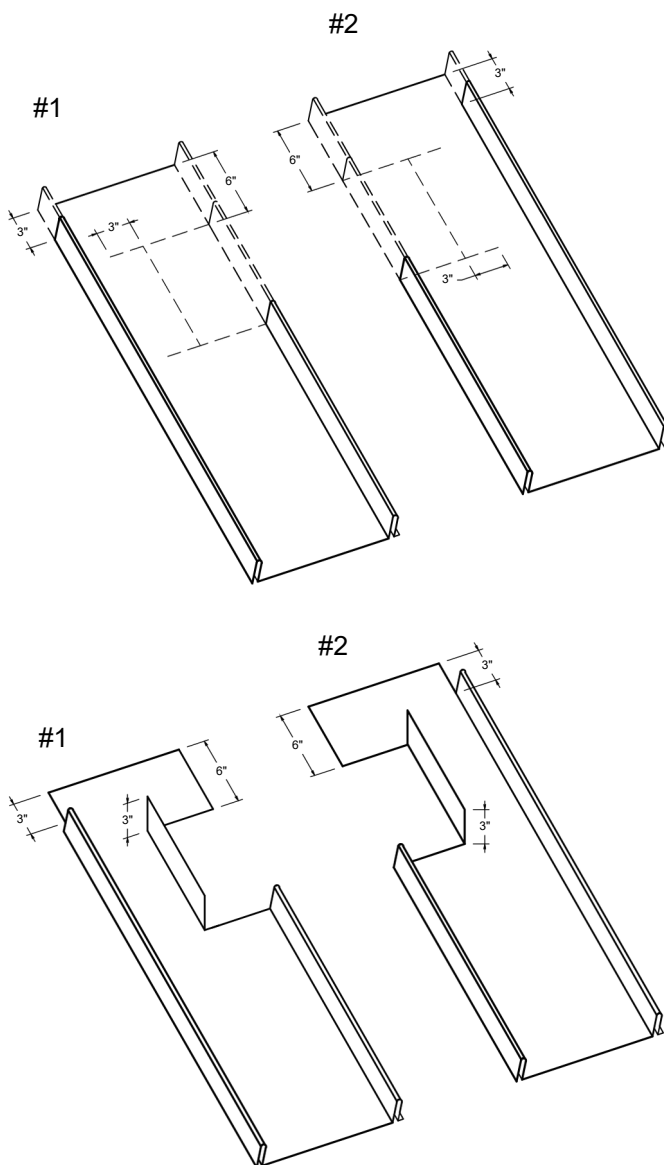

*Parts shown after they have been cut and bent.*

**Step 1:** Working from left to right, cut to fit, bend and install panel #1.

**Step 2:** Cut to fit, bend and install panel #2. *(Install additional panels as normal, between panels #1 and #2, as needed to cover width of skylight/chimney opening).*

**Step 3:** The next piece to install is the pan flashing #3. First place a bead of skinning butyl sealant on top of panel #1 and #2 to stop any water from siphoning at the joint. Next, cut and bend the pan flashing to fit. The artificial ribs should be 1/2" high. Set and fasten.

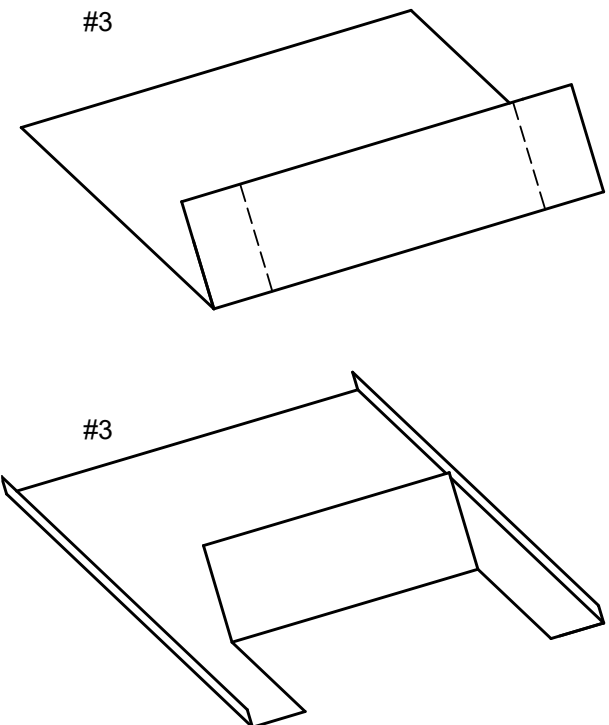

**#3 is the Pan flashing. Order the proper size for the curb height of your skylight, 5-1/2" (SLP5) or 3-1/2" (SLP3).**

**Parts #6, #7 and #8 are all the Sidewall flashing (SLSW). The only difference is the way they are cut and bent on the job. Again, order the proper size curb height of your skylight.**

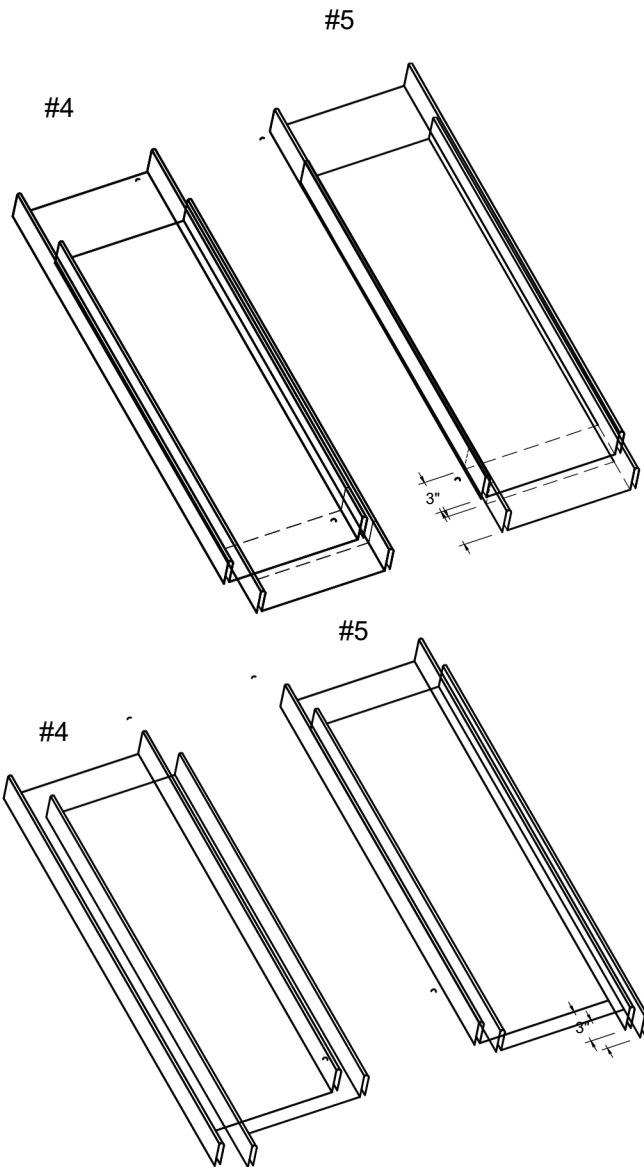

*Parts shown after they have been cut.*

**Step 4:** Working from left to right, cut and install panel #4, snapping it into place and continue fastening as usual.

**Step 5:** Cut and install panel #5. (Install additional panels as normal, between panels #1 and #2, as needed to cover width of skylight/chimney opening).

**Step 6:** Install the bottom flashing #6 as you would the standard endwall flashing. Next, apply sidewall flashing #7 and #8 finishing off around the curb of the skylight.

*Note: Skinning butyl sealant should be used at all joints and where the metal is to be overlapped.*

*Note: The care and attention to detail that is used when installing the flashings determines the overall finished appearance.*

*Note: The preceding information is designed as a general guideline to be used and is not the only acceptable method to flash a skylight.*

*Dotted lines show where to cut*

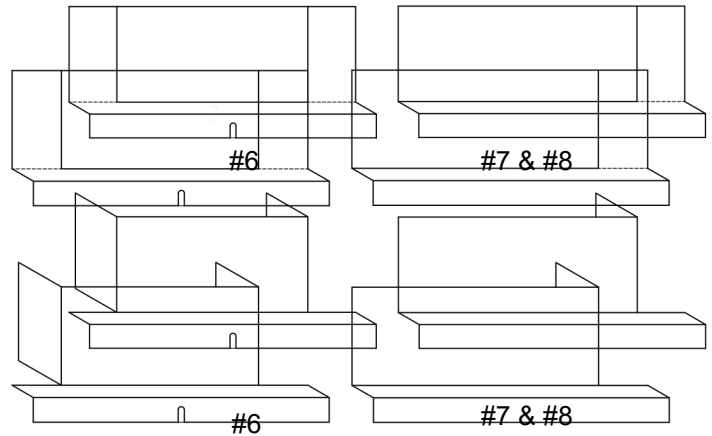

*Parts shown after they have been cut and bent.*

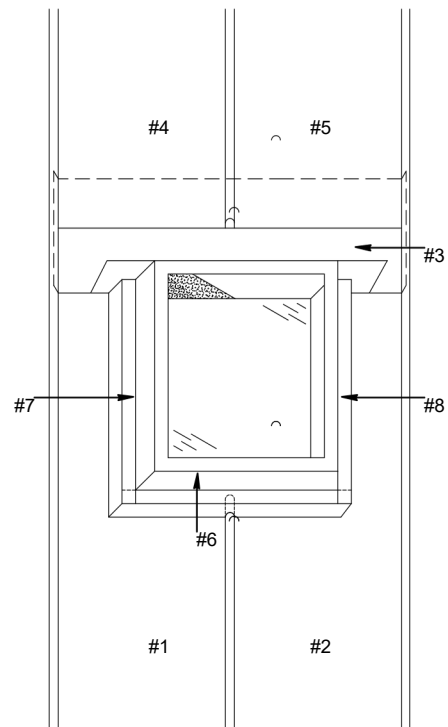

***Diagram of part placement around the skylight.***

FOR PIPES LOCATED 20' OR GREATER FROM PIN POINT

Allows panel and pipe flashing to move with temperature change.

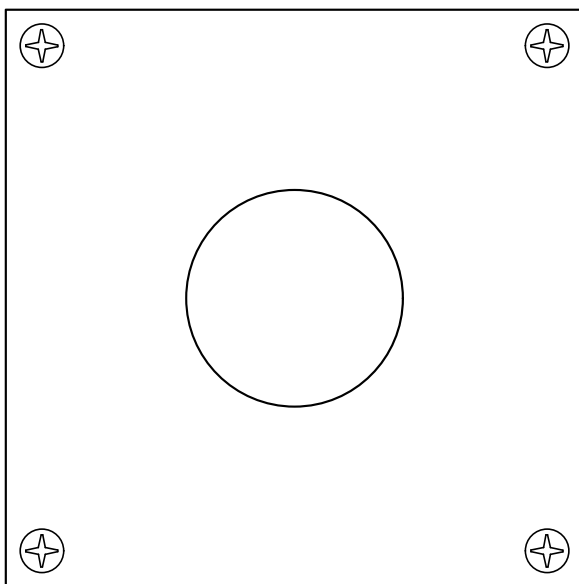
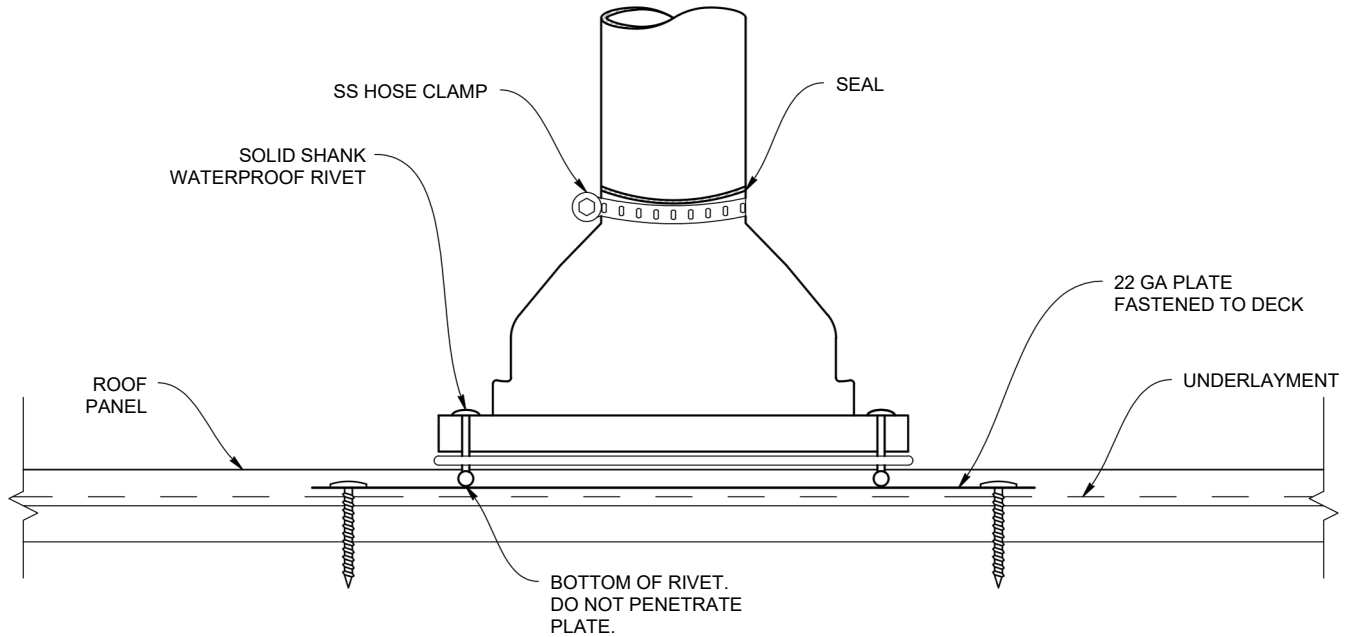

SINGLE 22 GAUGE PLATE

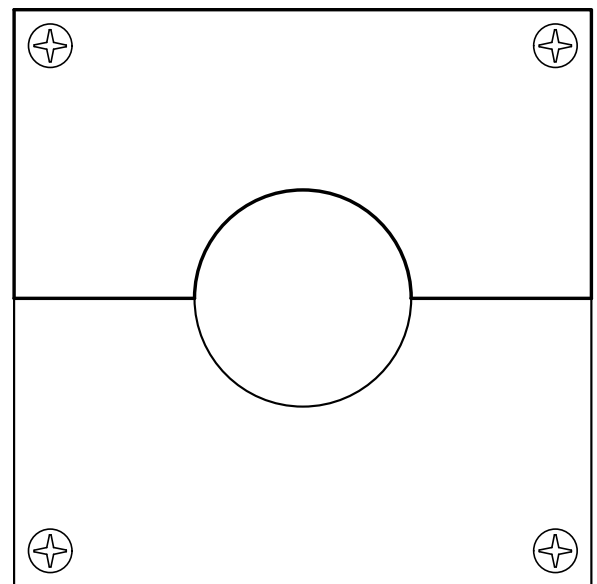

TWO OVERLAPPING 22 GAUGE PLATES

STEP 1

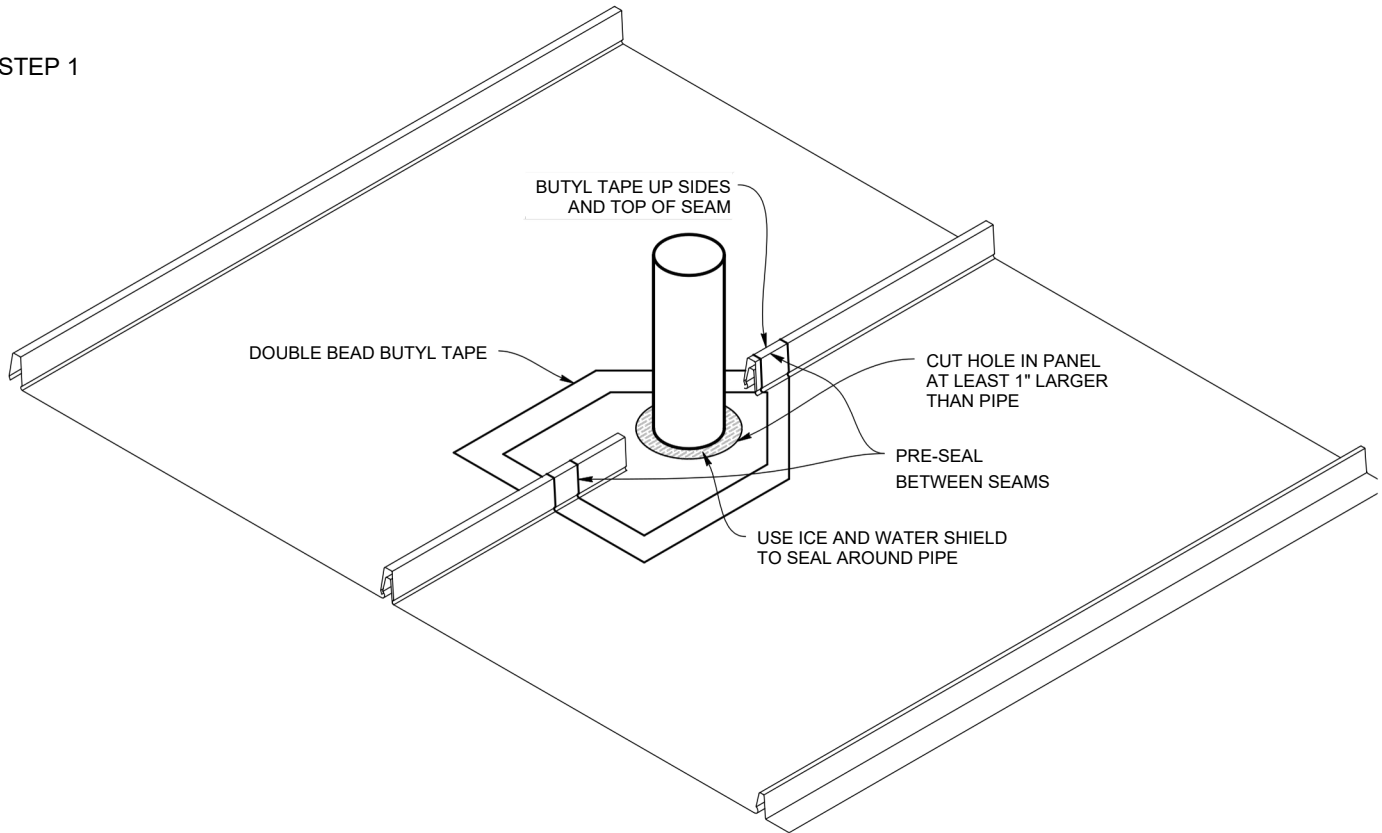

STEP 2

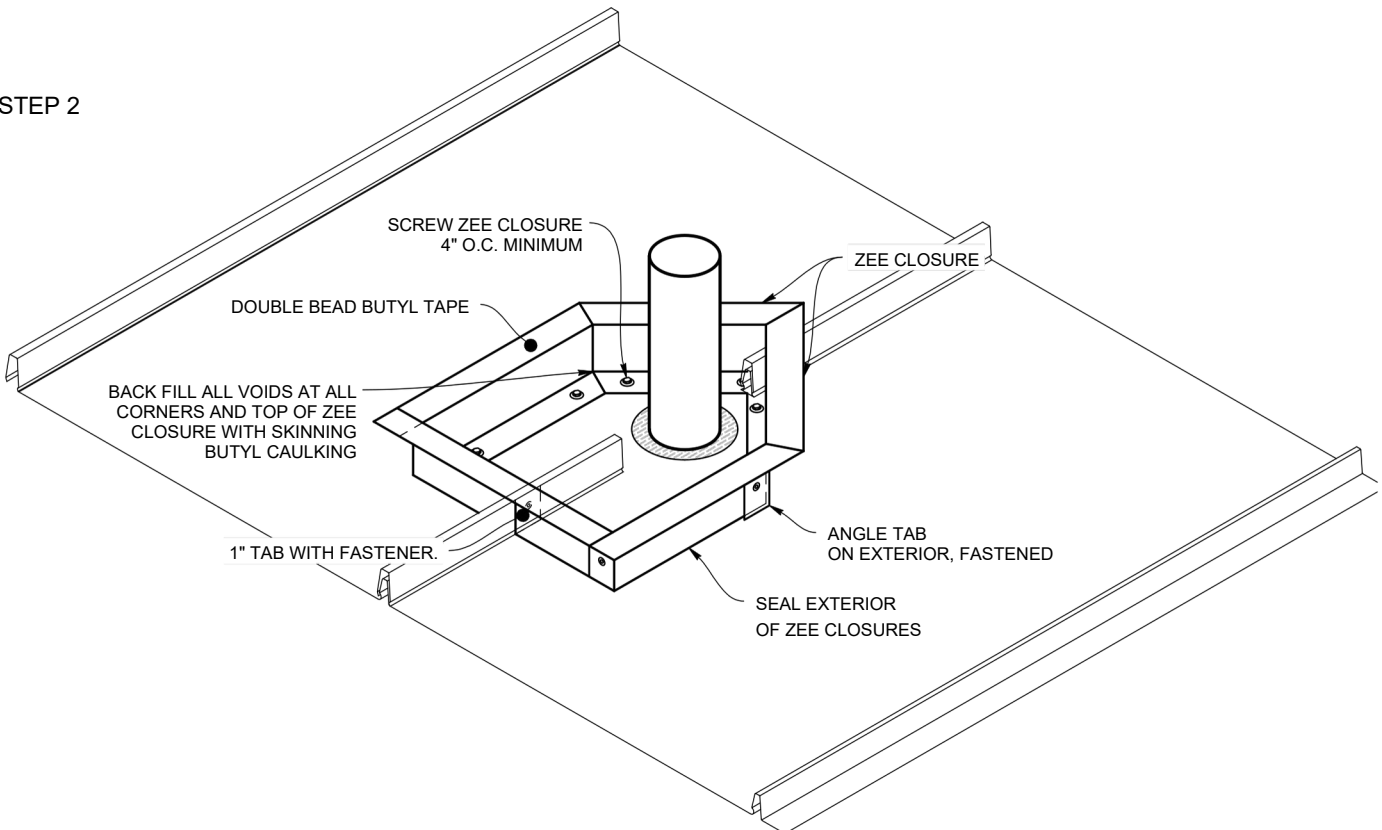

STEP 3

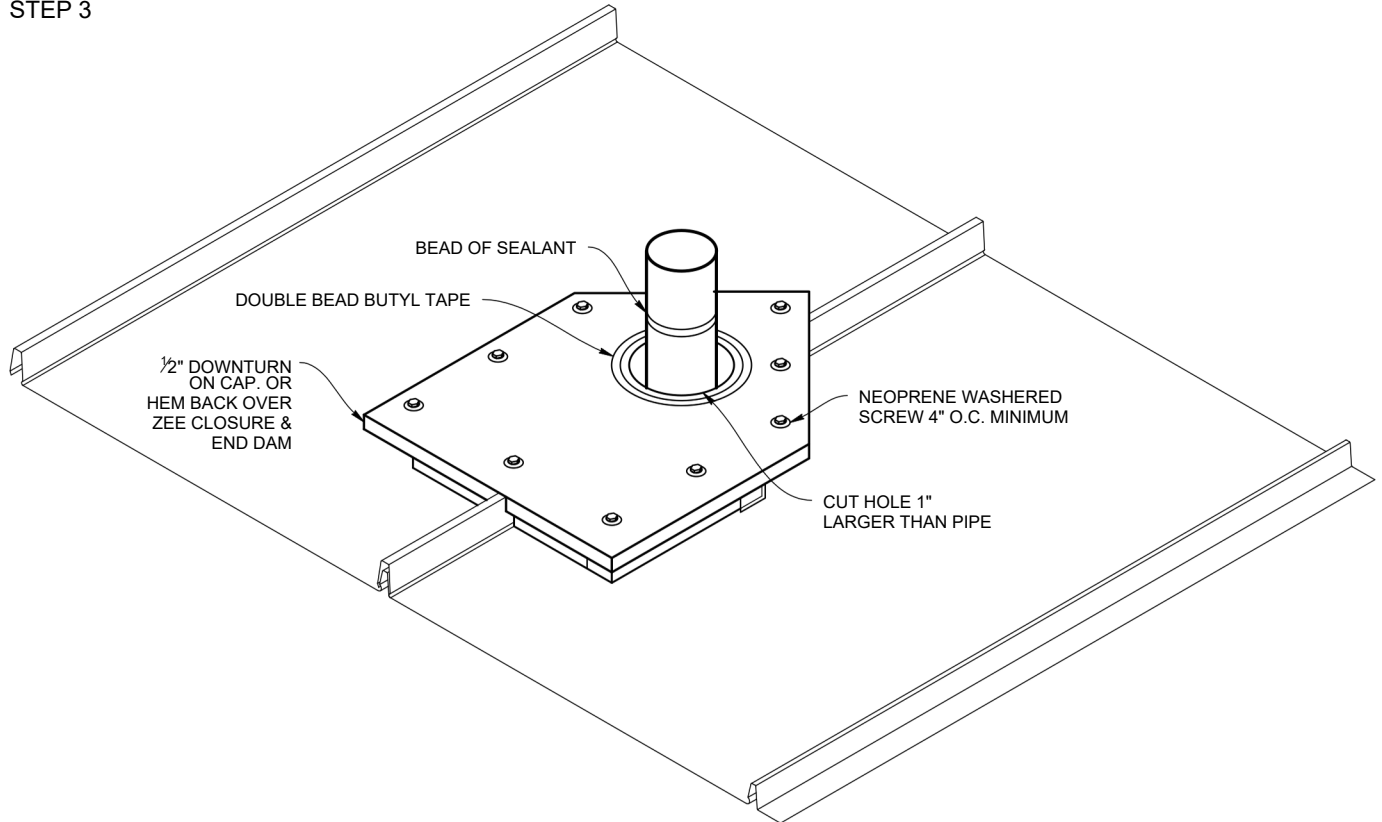

STEP 4

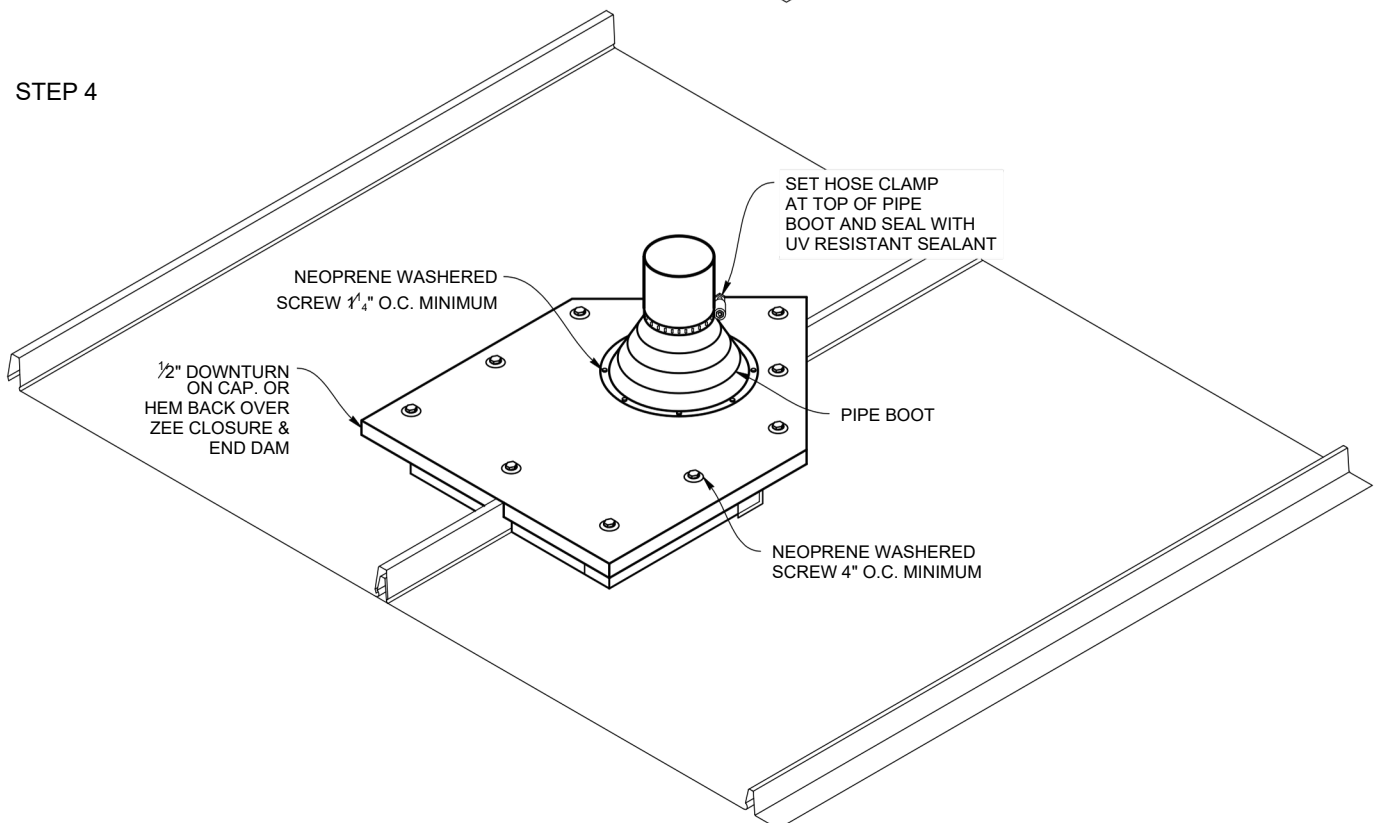

STEP 1

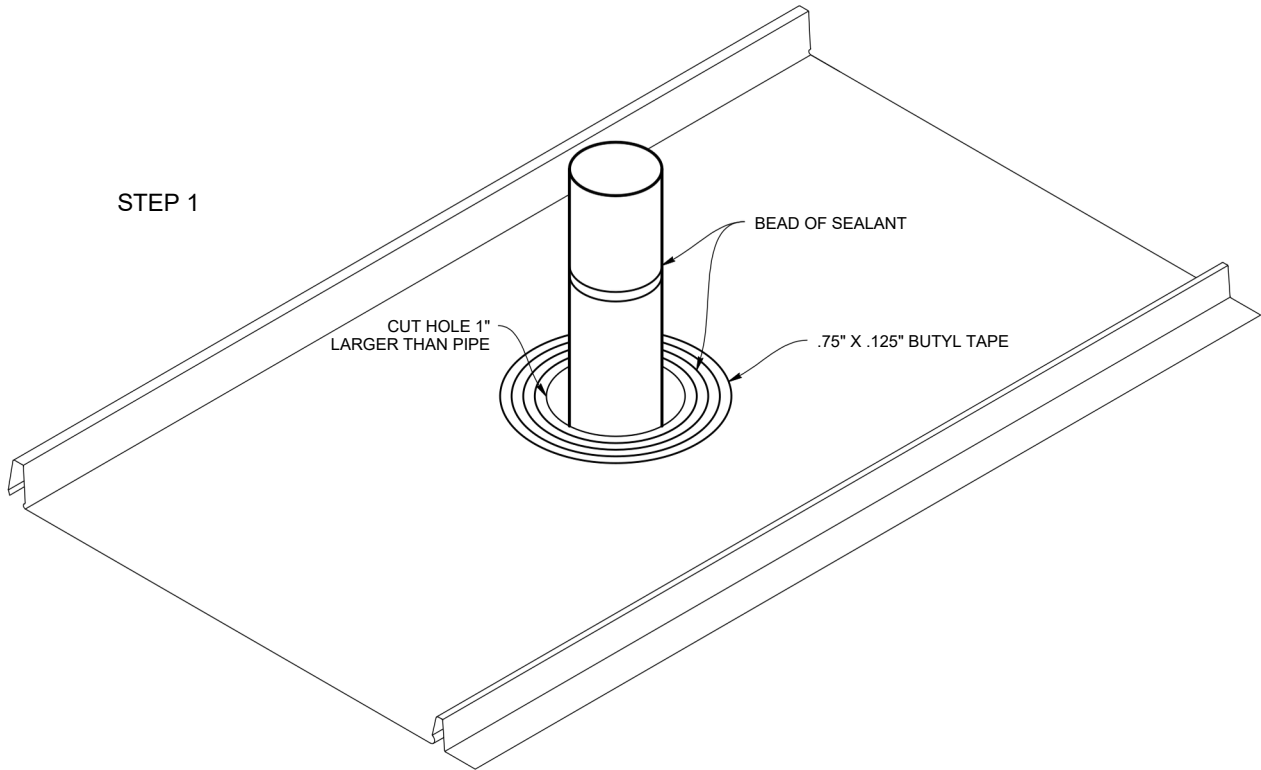

STEP 2

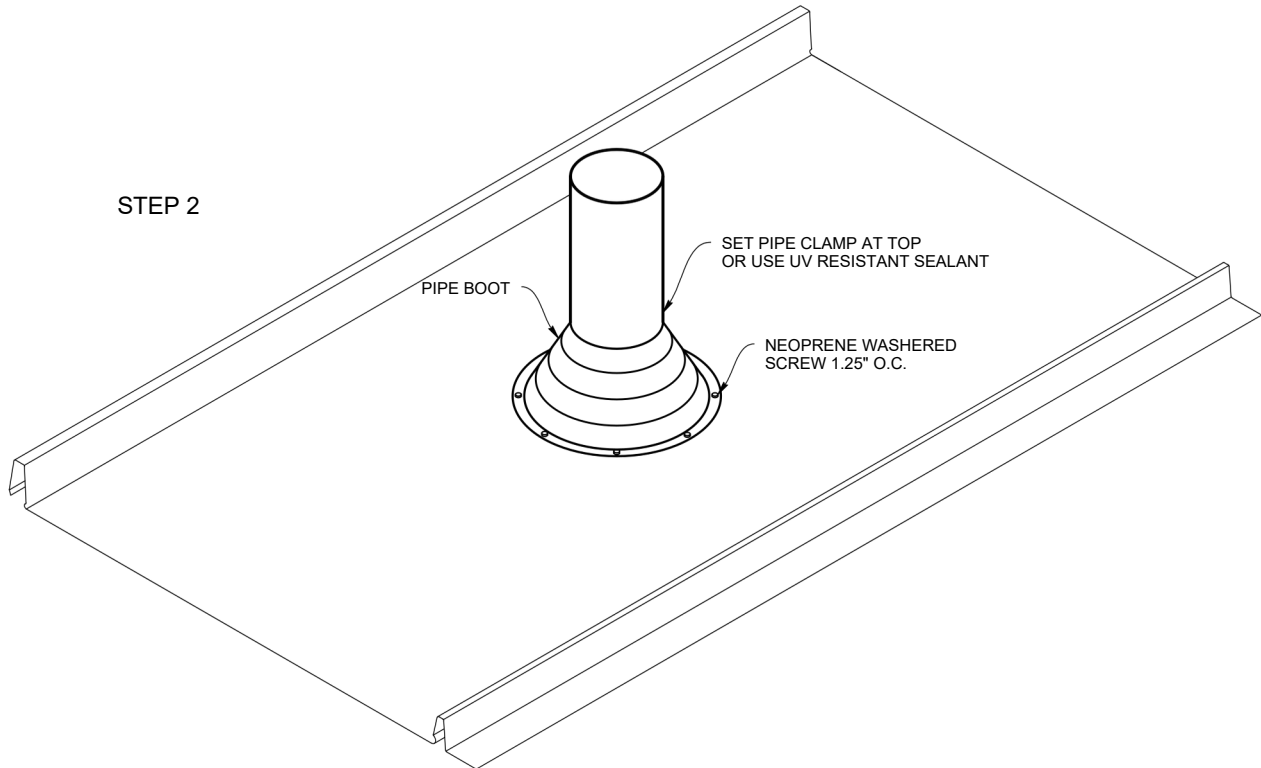

<p><b>EAVELOW PITCH (SLELP)</b></p> <p>SCALE 1:2      S.O. 6.25"      WEIGHT: 5.0 LBS.</p>	<p><b>1 1/2" EAVE (SLE1.5)</b></p> <p>SCALE 1:2      S.O. 6.5"      WEIGHT: 5.8 LBS.</p>	<p><b>HOOK EAVE (SLEH)</b></p> <p>SCALE 1:2      S.O. 8"      WEIGHT: 6.9 LBS.</p>
<p><b>EL 1"X3" EAVE FLASHING (SLE13)</b></p> <p>SCALE 1:2      S.O. 4.5"      WEIGHT: 3.4 LBS.</p>	<p><b>OFFSET CLEAT (10') (SLOC)</b></p> <p>NON-VISIBLE / SUB-FLASHING ARE NOT PROVIDE IN SPECIFIC COLORS UNLESS SPECIFIED</p> <p>SCALE 1:2      S.O. 3"      WEIGHT: 2.6 LBS.</p>	<p><b>BOXGUTTER (SL65BG)</b></p> <p>SCALE 1:4      S.O. 16"      WEIGHT: 13.1 LBS.</p>
<p><b>NARROW GABLE (SLGN)</b></p> <p>SCALE 1:3      S.O. 5.5625"      WEIGHT: 5.4 LBS.</p>	<p><b>COMPENSATING GABLE (SLGC)</b></p> <p>SCALE 1:3      S.O. 7.9375"      WEIGHT: 7.0 LBS.</p>	<p><b>COMPENSATING GABLE HEMMED (SLGCH)</b></p> <p>SCALE 1:3      S.O. 8.9375"      WEIGHT: 7.9 LBS.</p>

<p><b>GABLE G-17</b> (SLGG17)</p> <p>IF PAINTED, THIS SIDE</p> <p>2X 120°</p> <p>2 1/4"</p> <p>3/4"</p> <p>1 1/4"</p> <p>1/2" HEM, OPEN</p> <p>4"</p> <p>1/2" KICK, 1/2" HEM, OPEN</p> <p>135°</p> <p>SCALE 1:3      S.O. 9.75"      WEIGHT: 8.5 LBS.</p>	<p><b>BOXGABLE</b> (SLGB)</p> <p>IF PAINTED, THIS SIDE</p> <p>2"</p> <p>7/8"</p> <p>1/2" HEM</p> <p>4"</p> <p>1/2" KICK, 1/2" HEM, OPEN</p> <p>135°</p> <p>SCALE 1:3      S.O. 8.375"      WEIGHT: 7.2 LBS.</p>	<p><b>BOXGABLE NO HEM</b> (SLGBNH)</p> <p>IF PAINTED, THIS SIDE</p> <p>2"</p> <p>7/8"</p> <p>4"</p> <p>1/2" KICK</p> <p>135°</p> <p>SCALE 1:3      S.O. 7.375"      WEIGHT: 7.2 LBS.</p>
<p><b>GABLECLEAT (10')</b> (SLGCL)</p> <p>NON-VISIBLE / SUB-FLASHING ARE NOT PROVIDE IN SPECIFIC COLORS UNLESS SPECIFIED</p> <p>1"</p> <p>3 7/8"</p> <p>1/2" KICK</p> <p>135°</p> <p>SCALE 1:2      S.O. 5.375"      WEIGHT: 4.5 LBS.</p>	<p><b>ALTERNATE GABLE</b> (SLAG)</p> <p>IF PAINTED, THIS SIDE</p> <p>2 1/2"</p> <p>1/2"</p> <p>4"</p> <p>5/8" KICK, 1/2" HEM, OPEN AT 135°</p> <p>SCALE 1:3      S.O. 8.125"      WEIGHT: 6.6 LBS.</p>	<p><b>ALTERNATE GABLE CLEAT</b> (SLAGT)</p> <p>IF PAINTED, THIS SIDE</p> <p>2"</p> <p>7/8"</p> <p>1/2"</p> <p>3 7/8"</p> <p>1/2" KICK</p> <p>135°</p> <p>SCALE 1:3      S.O. 7.75"      WEIGHT: 6.3 LBS.</p>
<p><b>SUPPORT FLASHING (10')</b> (SLSF)</p> <p>NON-VISIBLE / SUB-FLASHING ARE NOT PROVIDE IN SPECIFIC COLORS UNLESS SPECIFIED</p> <p>1 1/2"</p> <p>1 1/8"</p> <p>1/2"</p> <p>1/2"</p> <p>1/8"</p> <p>2 1/2"</p> <p>SCALE 1:2      S.O. 6.125"      WEIGHT: 5.0 LBS.</p>	<p><b>PROW</b> (SLPF)</p> <p>IF PAINTED, THIS SIDE</p> <p>1/2" HEM, OPEN</p> <p>12.5"</p> <p>1"</p> <p>1"</p> <p>4"</p> <p>1/2" KICK, 1/2" HEM,</p> <p>SCALE 1:6      S.O. 20"      WEIGHT: 13.8 LBS.</p>	<p><b>FIELDNOTCHED RIDGE (UNVENTED)</b> (SLRS)</p> <p>IF PAINTED, THIS SIDE</p> <p>6"</p> <p>5/8"</p> <p>7/8"</p> <p>SPECIFY PITCH</p> <p>3/4"</p> <p>SCALE 1:6      S.O. 16.5"      WEIGHT: 13.1 LBS.</p>

<p><b>RIDGEFULL VENTED (SLRFV)</b></p> <p>IF PAINTED, THIS SIDE</p> <p>SPECIFY PITCH</p> <p>4X 96°</p> <p>5/8"</p> <p>3/4"</p> <p>SCALE 1:5      S.O. 16.75"      WEIGHT: 13.1 LBS.</p>	<p><b>R-17RIDGE (SLR17)</b></p> <p>IF PAINTED, THIS SIDE</p> <p>SPECIFY PITCH</p> <p>7 1/2"</p> <p>4X 117°</p> <p>1/2" HEM, OPEN</p> <p>1 1/2"</p> <p>SCALE 1:5      S.O. 20"      WEIGHT: 15.6 LBS.</p>	
<p><b>VENTEDPEAK FLASHING (SLRECV)</b></p> <p>IF PAINTED, THIS SIDE</p> <p>SPECIFY PITCH</p> <p>6"</p> <p>3/4"</p> <p>1 1/2"</p> <p>5 1/2"</p> <p>SLIGHTLY OPEN HEM</p> <p>1/2" KICK, 1/2" HEM AT 135°</p> <p>S.O. 14.625"</p> <p>WEIGHT: 11.80 LBS.</p> <p>SCALE 1:4</p>	<p><b>PEAK CLEAT (SLRECC)</b></p> <p>SPECIFY PITCH</p> <p>1"</p> <p>4 1/2"</p> <p>1/2" KICK</p> <p>135°</p> <p>S.O. 5.625"</p> <p>WEIGHT: 4.5 LBS.</p> <p>SCALE 1:4</p> <p>NON-VISIBLE SUB-FLASHING ARE NOT PROVIDE IN SPECIFIC COLORS UNLESS SPECIFIED</p>	
<p><b>HEMMEDPEAK FLASHING (SLRECH)</b></p> <p>IF PAINTED, THIS SIDE</p> <p>SPECIFY PITCH</p> <p>6"</p> <p>1"</p> <p>4 1/4"</p> <p>SLIGHTLY OPEN HEM</p> <p>1/2" KICK, 1/2" HEM AT 135°</p> <p>S.O. 11.75"      WEIGHT: 10.75 LBS.</p> <p>SCALE 1:4</p>	<p><b>FIELDNOTCHED PEAK FLASHING (SLREC)</b></p> <p>IF PAINTED, THIS SIDE</p> <p>SPECIFY PITCH</p> <p>5 1/2"</p> <p>7/8"</p> <p>4 1/2"</p> <p>1/2" KICK, 1/2" HEM AT 135°</p> <p>135°</p> <p>S.O. 11.875"      WEIGHT: 8.4 LBS.</p> <p>SCALE 1:4</p>	<p><b>FIELDNOTCHED HIP (SLHS)</b></p> <p>IF PAINTED, THIS SIDE</p> <p>SPECIFY PITCH</p> <p>5"</p> <p>5/8"</p> <p>3/4"</p> <p>7/8"</p> <p>6X 96°</p> <p>S.O. 14.5"      WEIGHT: 12.1 LBS.</p> <p>SCALE 1:6</p>
<p><b>HIP/RIDGE (SPECIFY) (SLHR5.625)</b></p> <p>IF PAINTED, THIS SIDE</p> <p>SPECIFY PITCH</p> <p>5 1/2"</p> <p>1" HEM, OPEN</p> <p>S.O. 13.25"      WEIGHT: 10.1 LBS.</p> <p>SCALE 1:4</p>	<p><b>HIP/RIDGE (SPECIFY) (SLHR7)</b></p> <p>IF PAINTED, THIS SIDE</p> <p>SPECIFY PITCH</p> <p>7"</p> <p>1" HEM, OPEN</p> <p>S.O. 16"      WEIGHT: 13.1 LBS.</p> <p>SCALE 1:4</p>	

**VALLEY FLASHING 24" HEMMED**  
(SLVF24H)

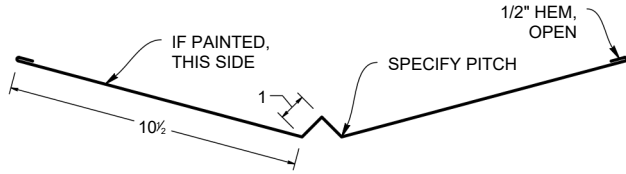

SCALE 1:7

S.O. 24"

WEIGHT: 19.6 LBS.

**VALLEY FLASHING 24"**  
(SLVF24)

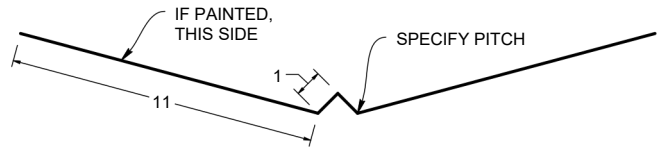

SCALE 1:7

S.O. 24"

WEIGHT: 19.6 LBS.

**VALLEY WIDE FLASHING**  
(SLVFW)

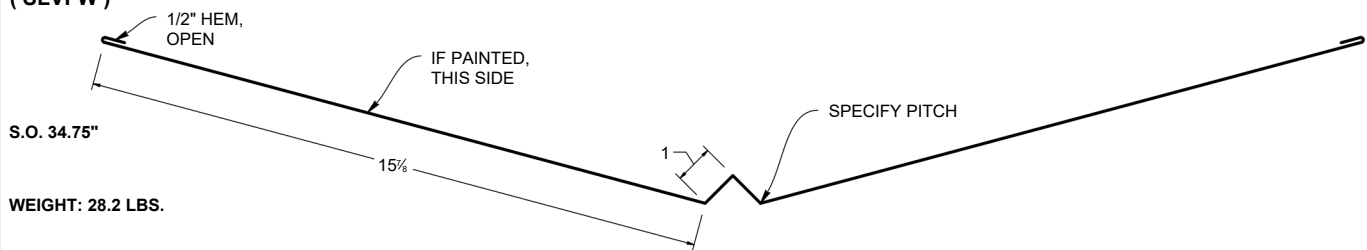

S.O. 34.75"

WEIGHT: 28.2 LBS.

SCALE 1:5

**FIELD NOTCHED INSIDE PITCH CHANGE**  
(SLPCIN)

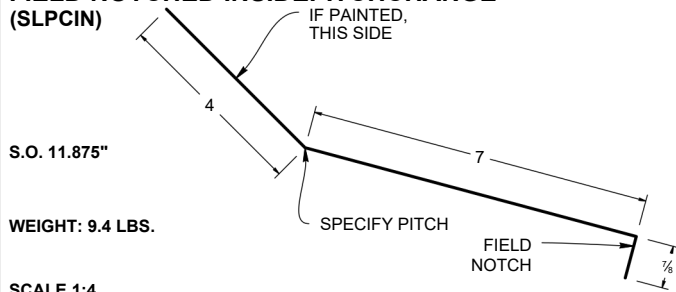

S.O. 11.875"

WEIGHT: 9.4 LBS.

SCALE 1:4

**FIELD NOTCHED OUTSIDE PITCH CHANGE**  
(SLPCON)

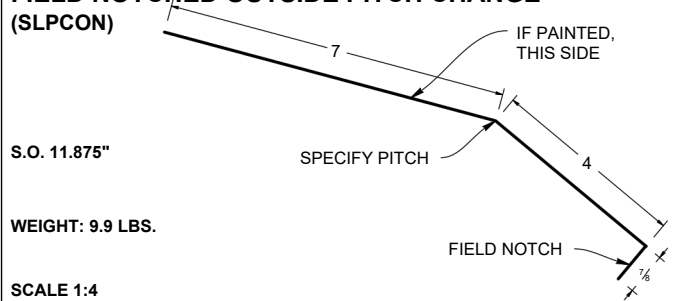

S.O. 11.875"

WEIGHT: 9.9 LBS.

SCALE 1:4

**OUTSIDE PITCH CHANGE HEMMED**  
(SLPCOH)

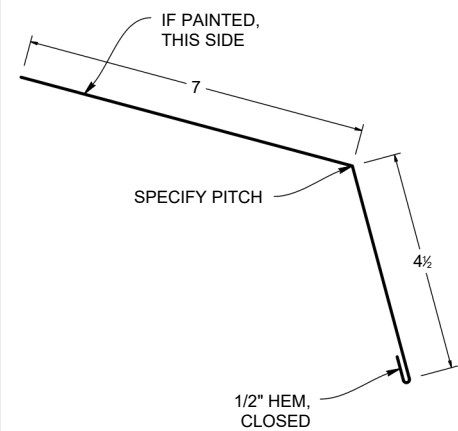

SCALE 1:4

S.O. 12"

WEIGHT: 9.9 LBS.

**INSIDE PITCH CHANGE HEMMED**  
(SLPCIH)

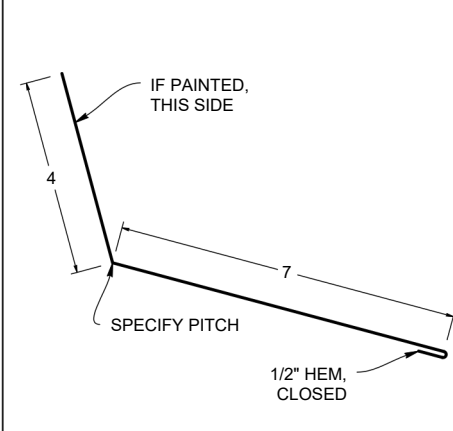

SCALE 1:4

S.O. 11.5"

WEIGHT: 9.1 LBS.

<p><b>HEMMED ENDWALL (SLEWH)</b></p> <p>SCALE 1:3      S.O. 9.5"      WEIGHT: 7.9 LBS.</p>	<p><b>FIELDNOTCHED ENDWALL (SLEWN)</b></p> <p>SCALE 1:3      S.O. 9.625"      WEIGHT: 8.1 LBS.</p>	<p><b>EW-17VENTED ENDWALL (SLEW17)</b></p> <p>SCALE 1:4      S.O. 13.25"      WEIGHT: 11.5 LBS.</p>
<p><b>SIDEWALL (SLSW)</b></p> <p>SCALE 1:3      S.O. 5.875"      WEIGHT: 5.0 LBS.</p>	<p><b>COMPENSATING SIDEWALL (SLSWC)</b></p> <p>SCALE 1:3      S.O. 7.375"      WEIGHT: 5.8 LBS.</p>	<p><b>PAN (SLPAN)</b></p> <p>SCALE 1:3      S.O. 18"      WEIGHT: 14.6 LBS.</p>
<p><b>5.5" PAN FLASHING (SLP5)</b></p> <p>S.O. 18"</p> <p>WEIGHT: 14 LBS.</p> <p>SCALE 1:5</p>	<p><b>3.5" PAN FLASHING (SLP3)</b></p> <p>S.O. 16"</p> <p>WEIGHT: 13 LBS.</p> <p>SCALE 1:5</p>	
<p><b>GUTTER HANGER (AGH6)</b></p> <p>NON-VISIBLE SUB-FLASHING ARE NOT PROVIDE IN SPECIFIC COLORS UNLESS SPECIFIED</p> <p>S.O. 8"</p> <p>WEIGHT: 6.5 LBS.</p> <p>SCALE 1:2</p>		

<p><b>C-FLASHING (SLCF)</b></p> <p>SCALE 1:2      S.O. 5.375"      WEIGHT: 4.5 LBS.</p>	<p><b>ZEE CLOSURE (SLZC)</b></p> <p>SCALE 1:2      S.O. 2.875"      WEIGHT: 2.64 LBS.</p>	
<p><b>4" PERF STRIP (SLPS)</b>      ONLY IN 24 GA ZINCALUM</p> <p>NON-VISIBLE SUB-FLASHING ARE NOT PROVIDE IN SPECIFIC COLORS UNLESS SPECIFIED</p> <p>SCALE 1:2      S.O. 4"      WEIGHT: 2.5 LBS.</p>	<p><b>REVERSING STRIP (SLSR)</b></p> <p>SCALE 1:1      S.O. 2"      WEIGHT: 1.8 LBS.</p>	
<p><b>OFFSET CLEAT (10') (SLOC)</b></p> <p>NON-VISIBLE SUB-FLASHING ARE NOT PROVIDE IN SPECIFIC COLORS UNLESS SPECIFIED</p> <p>SCALE 1:2      S.O. 3"      WEIGHT: 2.6 LBS.</p>	<p><b>GABLE CLEAT (10') (SLGCL)</b></p> <p>NON-VISIBLE SUB-FLASHING ARE NOT PROVIDE IN SPECIFIC COLORS UNLESS SPECIFIED</p> <p>SCALE 1:2      S.O. 5.375"      WEIGHT: 4.5 LBS.</p>	<p><b>PEAK CLEAT (10') (SLRECC)</b></p> <p>NON-VISIBLE SUB-FLASHING ARE NOT PROVIDE IN SPECIFIC COLORS UNLESS SPECIFIED</p> <p>SCALE 1:2      S.O. 5.625"      WEIGHT: 4.5 LBS.</p>
<p><b>END DAM</b></p> <p>S.O. 8"</p> <p>WEIGHT: 6.5 LBS.</p>		

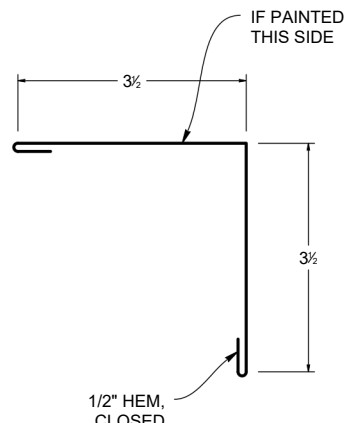
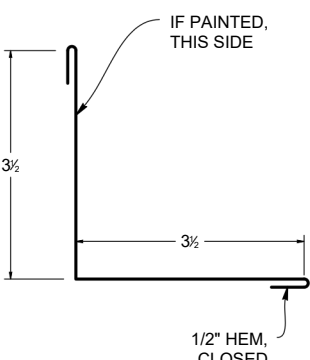
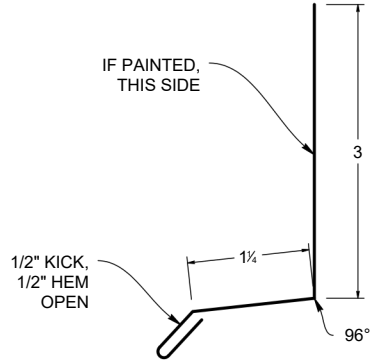
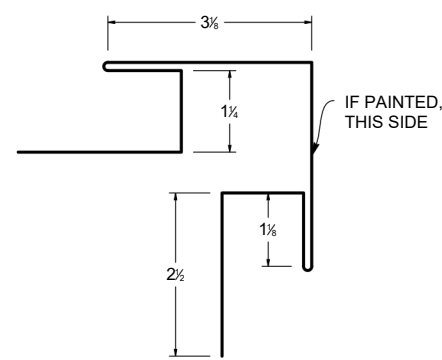
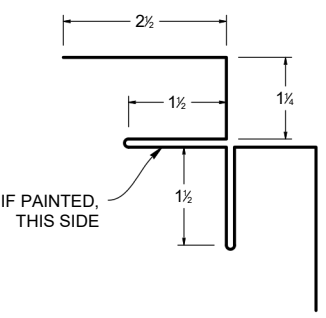
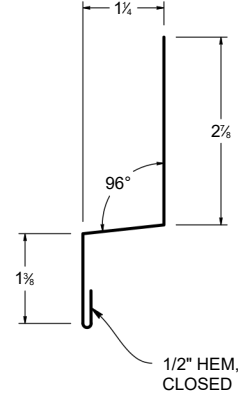
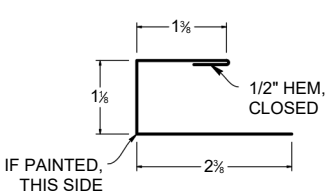
<p><b>OUTSIDE CORNER</b> (SLCOA)</p>  <p>IF PAINTED, THIS SIDE</p> <p>3 1/2</p> <p>3 1/2</p> <p>1/2" HEM, CLOSED</p> <p>SCALE 1:3      S.O. 8"      WEIGHT: 7.3 LBS</p>	<p><b>INSIDE CORNER</b> (SLCIA)</p>  <p>IF PAINTED, THIS SIDE</p> <p>3 1/2</p> <p>3 1/2</p> <p>1/2" HEM, CLOSED</p> <p>SCALE 1:3      S.O. 8"      WEIGHT: 7.3 LBS</p>	<p><b>BASE FLASHING</b> (SLBF)</p>  <p>IF PAINTED, THIS SIDE</p> <p>3</p> <p>1/2" KICK, 1/2" HEM OPEN</p> <p>1/4</p> <p>96°</p> <p>SCALE 1:3      S.O. 5.25"      WEIGHT: 4.3 LBS</p>
<p><b>OUTSIDE CORNER POST</b> (SLCPO)</p>  <p>IF PAINTED, THIS SIDE</p> <p>3 1/2</p> <p>1 1/4</p> <p>1 1/8</p> <p>2 1/2</p> <p>SCALE 1:3      S.O. 16"      WEIGHT: 7.3 LBS</p>	<p><b>INSIDECORNER POST</b> (SLCPI)</p>  <p>IF PAINTED, THIS SIDE</p> <p>2 1/2</p> <p>1 1/2</p> <p>1 1/4</p> <p>1 1/2</p> <p>SCALE 1:3      S.O. 13.5"      WEIGHT: 7.3 LBS</p>	<p><b>ZEEFLASHING HEMMED</b> (SLZFH)</p>  <p>1 1/4</p> <p>2 1/4</p> <p>96°</p> <p>1 3/8</p> <p>1/2" HEM, CLOSED</p> <p>SCALE 1:3      S.O. 6"      WEIGHT: 4.5 LBS</p>
<p><b>C-FLASHING HEMMED</b> (SLCF)</p>  <p>IF PAINTED, THIS SIDE</p> <p>1 1/4</p> <p>1 1/4</p> <p>1/2" HEM, CLOSED</p> <p>2 1/4</p> <p>SCALE 1:3      S.O. 5.375"      WEIGHT: 4.5 LBS</p>		