

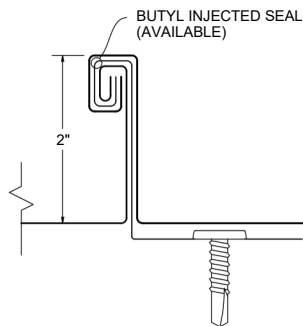

MS-200™ Installation Guide

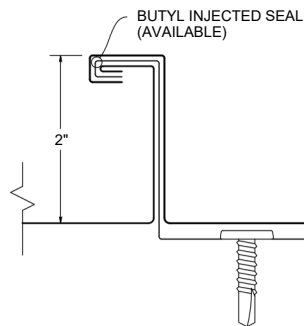

● Panel Specifications.....	4-5	● Peak Flashing (R.E.C).....	23
● Floating Panel Clip.....	6	● Vented Peak Flashing (R.E.C).....	24
● Delivery & Will Call/Loading.....	7-8	● Pitch Change.....	25
● Notes to Designer/Installer.....	9-10	● Endwall.....	26
● Handling & Storage.....	1.1	● Vented Endwall.....	27
● Standard Eave.....	1.2	● Saw Cut Endwall.....	28
● Hook Eave.....	13	● Curb Back Pan/Cricket.....	29-31
● Gutter/Hook Eave.....	14	● Curb Sidewall.....	32
● Standard Ridge.....	15	● Curb Endwall.....	33
● Vented Ridge.....	16	● Curb/Pan Cricket.....	34
● End Dam.....	17	● Eave to Gable Transition.....	35-37
● Valley - High Pitch.....	18	● Pipe Penetration - On Plate.....	38
● Valley - Low Pitch.....	19	● Pipe Penetration - On Rib.....	39-40
● Box Gable.....	2.0	● Pipe Penetration - On Pan.....	41
● Alternate Gable.....	21	● Flashing Selection.....	42-46
● Sidewall.....	22		

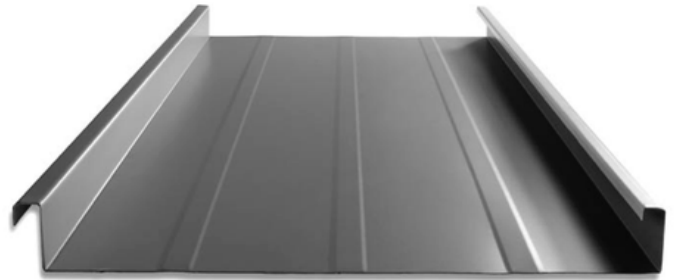
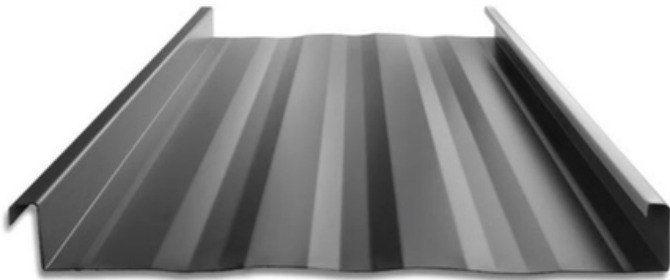
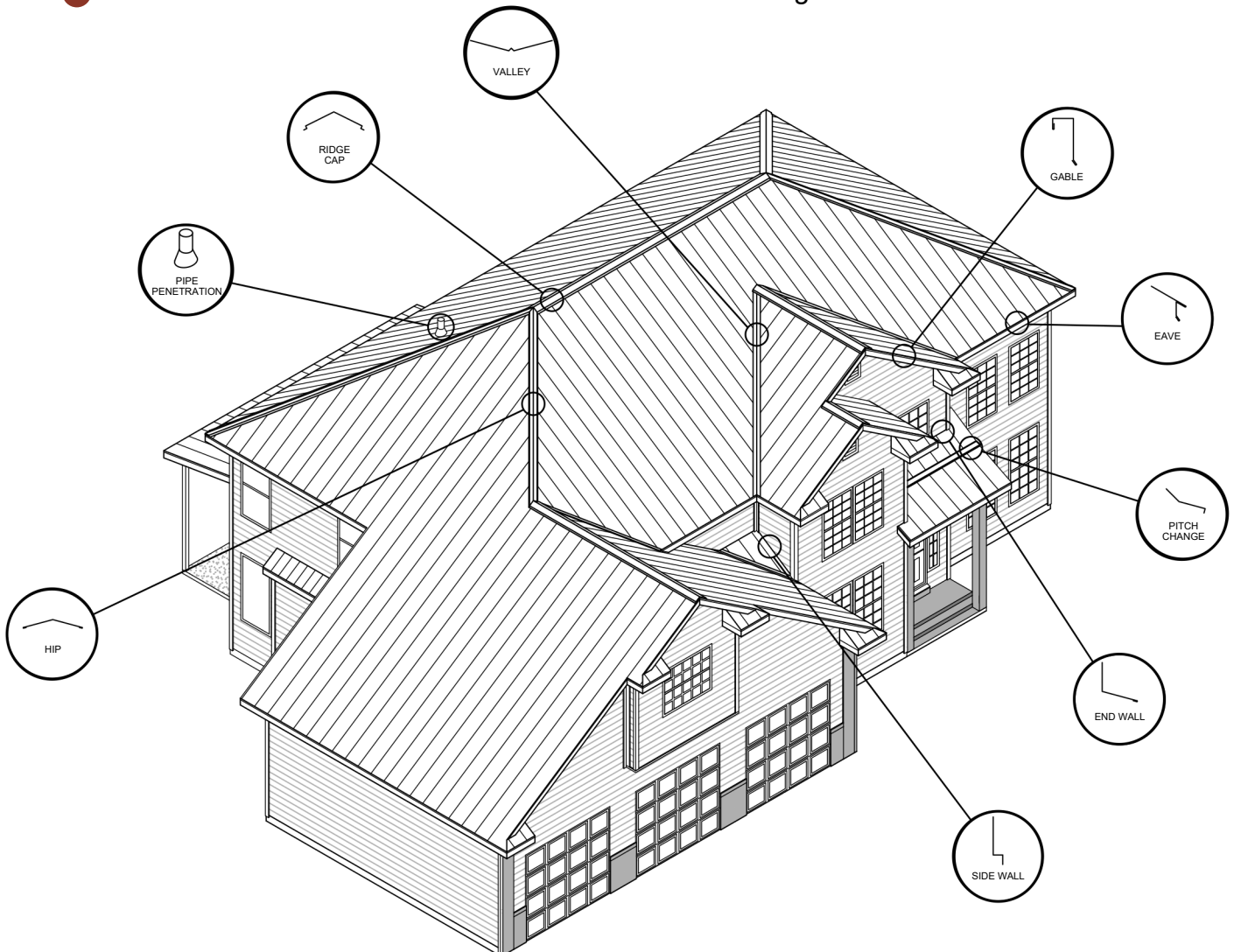



ICC-ES EVALUATION REPORT #5046 with CBC-CRC Supplement

12", 14" 16" & 18" coverage options

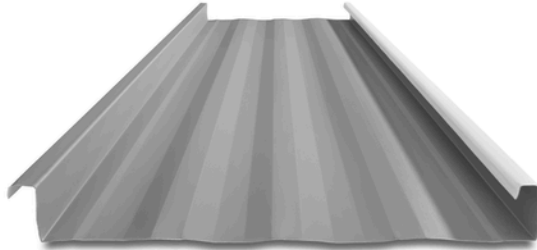

STRIATIONS

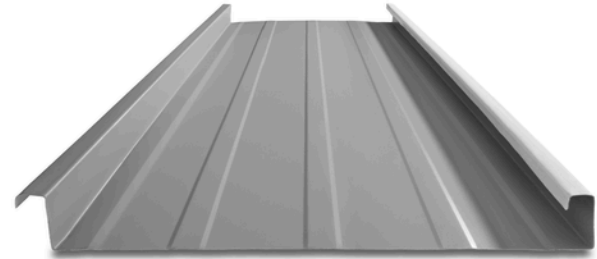

ACCENT RIBS

2 Accent ribs for 12" & 14" panels (Salem & Riverside)
3 Accent ribs for 16" & 18" panels

2 Accent ribs for all panels (Sacramento)

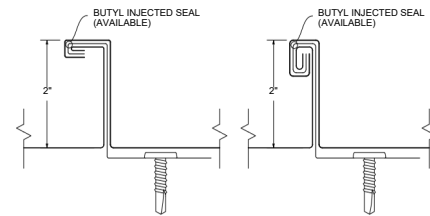



90° SEAM DETAIL 180° SEAM DETAIL

The MS-200™ is a mechanically seamed roof that is perfect for high wind areas and snow country. The butyl injected seam prevents water from entering the system, giving you a worry free roof for a lifetime.

KEY FEATURES

- 12", 14", 16" & 18" coverage options
- 24 and 22 Tru-Gauge™ and .032" and .040 Aluminum
- Zinc Coil (inquire for thickness)
- Floating clip system: allows for expansion and contraction of panels in longer lengths
- 2" vertical rib, factory notching available
- 1/2:12 minimum pitch recommended (For lower pitches, please inquire)
- Standard panel lengths 1' to 60' (For longer length panels, please inquire)
- On-site roll forming available for longer panels
- Factory injected Butyl sealant available
- Clip Relief is not standard, available upon request
- Concealed fastener: fasteners cannot leak
- Weathertightness warranty available (Contact NMP representative for details)
- OverEZee retro-fit system available
- Panel options: Striations, Accent Rib, Flat Pan
- Manufactured in Sacramento CA

TESTING

-  ICC-ESR #5046 with CBC-CRC Supplement
-  Code compliance UL Evaluation Report UL ER #25913-01
- UL Construction No. 90, 176, 180, 238, 238A, 238B, 238C, 312, 335, 403, 435, 435A, 437, 449, 451, 487, 506, 506A, 506B, 576, 577, 583, 608 & 610
- UL 580 Class 90 - Wind Uplift
- UL 790 Class A (ASTM E108) - Fire rated
- UL 2218 Class 4 - Impact (hail) rated
- FM Class 4471 - 1-75/120 wind uplift, Class A fire spread, severe hail & foot traffic
- ASTM E1680 - Air infiltration (roof)
- ASTM E1646 - Water infiltration (roof)
- ASTM E1592 - Structural uniform static air pressure
- ASTM E331 - Water infiltration (wall)
- ASTM E283 - Air infiltration (wall)
- ASTM A653/A924 - G90 Galvanized
- ASTM A792 - Zincalume/Galvalume AZ-50/55
- ASTM B209 - Aluminum Substrate
- ASTM E2140 - Standard Test Method for Water Penetration (full immersion)
- ASTM E1514 Standard for Structural Standing steel roof panels systems.
- ASTM E2886 - Ember Resistant ridge/endwall/peak flashings available

MATERIAL SPECIFICATIONS

- 24 Tru-Gauge™ Kynar 500® Painted Steel
- ▲ 22 Tru-Gauge™ Kynar 500® Painted Steel
- ◆ .032" Kynar 500® Painted Aluminum
- 24 Tru-Gauge™ G-90 Galvanized or AZ-50
- 24 and 22 Tru-Gauge™ bare Zinalume® Plus AZ-55 (No finish warranty – 25 yr. perforation warranty)
- G-90 Galvanized or AZ-50
- .040" Kynar 500® Painted Aluminum (please inquire)
- 24 Tru-Gauge™ Bonderized
- 22 gauge Rusteel Plus™ (A606)
- Custom 20 & 18 Tru-Gauge™ and .050" and .063" Aluminum (please inquire)
- 16 OZ & 20 OZ Real Copper (please inquire)
- Kynar 500® and substrate testing data available (See website)
- PVDF is a fluoropolymer that is manufactured under the trademarked names Kynar 500® and Duranar®(PPG). Paint finishes containing a minimum 70% PVDF resin meet the high-performance weathering criteria established by the American Architectural Manufacturing Association and are allowed to carry the Kynar500® trademarked name. Zinalume & Zinalume® Plus are registered trademarks of Bluescope Ltd. Galvalume® is a registered trademark of BIEC International, Inc. Vintage® is a registered trademark of Steelscape, Inc. Kynar® and Kynar 500® is a registered trademarks of Arkema, Inc.

FINISHES

- 21 Standard Colors, 5 Metallic Colors and 4 Specialized Colors
- Kynar 500® Paint System - the ultimate in exterior durability and color retention
- “Cool” color pigments are specially designed to reflect infrared light, reducing heat gain to dwelling, and conform with ENERGY STAR® criteria
- Superior quality, two coat, 70% resin finish, applied at a 1 mil. thickness
- 40 year residential paint warranty
- 20 and 30 year commercial paint warranty: Contact NMP for warranty specifications
- “Oil Canning” is an inherent characteristic of roof and wall products, and not a defect, which is not a cause for panel rejection

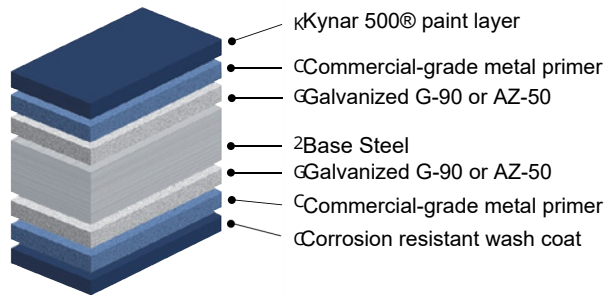

STANDARD COOL KYNAR 500® COLORS

▲ 22 Tru-Gauge™

◆ .032 Aluminum

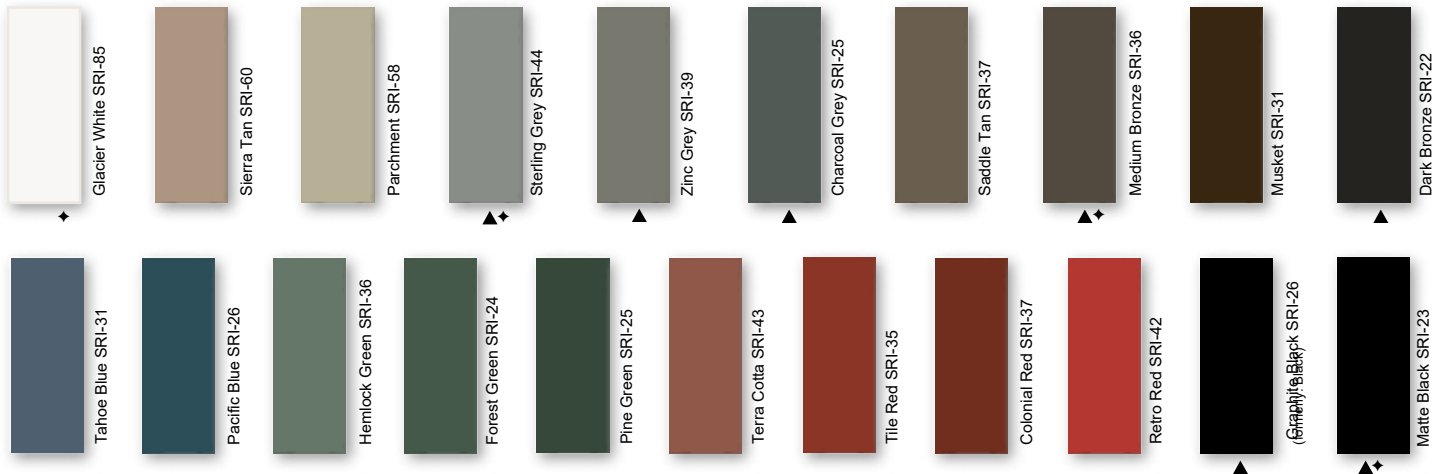

PREMIUM METALLIC COOL KYNAR® COLORS

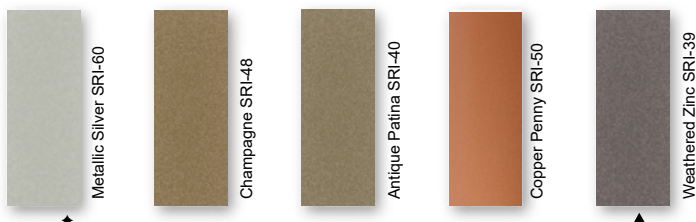

SPECIALIZED MATERIAL

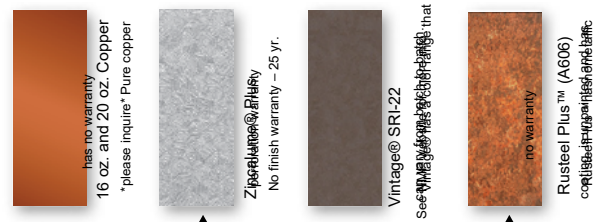

These printed chips provide a close representation of the colors.

Metal samples are available upon request. Coatings are low gloss 10-15% sheen. SRI = Solar Reflective Index. SRI values listed above are in accordance with ASTM E1980 and are based on actual testing. ***Oil canning is not a cause for material rejection***



**Nor-Cal Metal Products
MS-200™ - UL 90 Floating Clip
18 ga. Base/22 ga. Top**

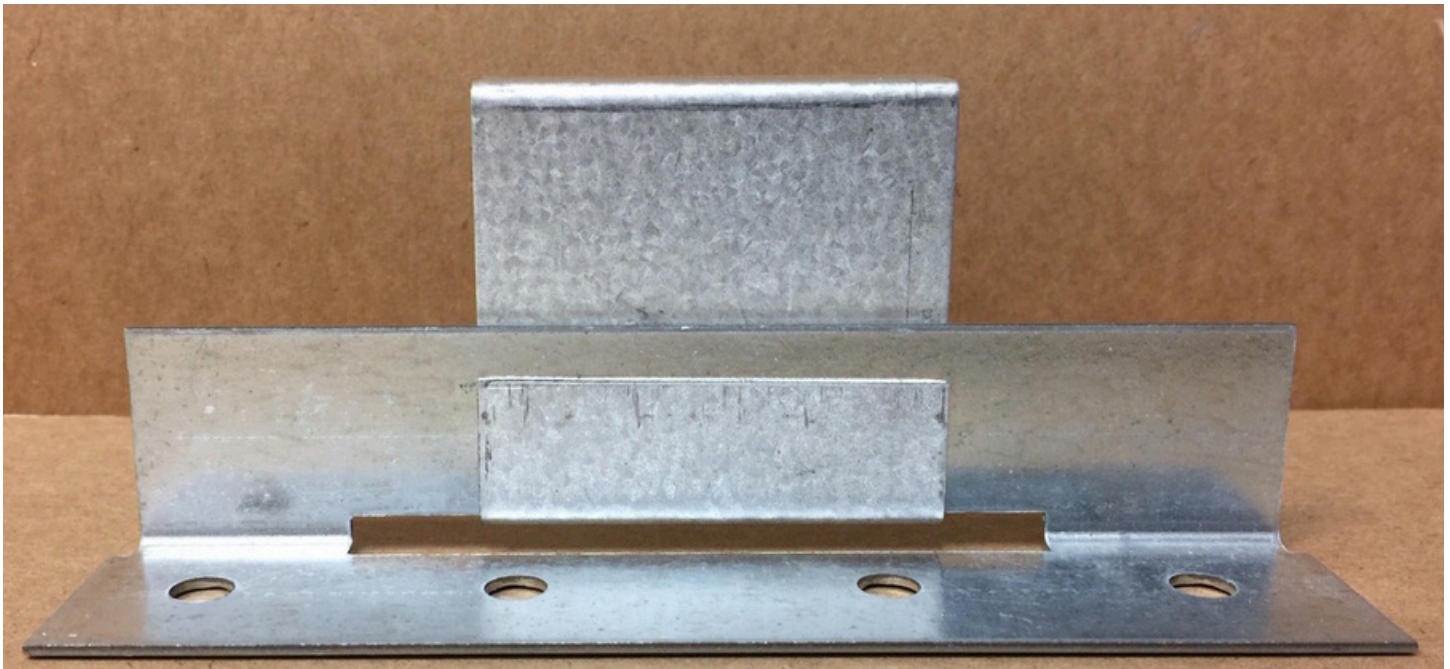

**UL 580 Class 90 Wind Uplift Rated
UL Class A Fire Rated**

Delivery Fleet

Nor-Cal Metal Products prides itself with quick lead times delivered with our fleet of semi trucks. Our fleet of trucks are owned and operated by NMP. All of our drivers are Nor-Cal Metal Products employees, so when your truck rolls in to deliver, you are dealing with Nor-Cal Metal Products.

Expect consistent and exceptional service with short leadtimes. The inhouse fleet allows for efficient and cost-effective delivery.



Mounted on the rear of our truck's trailer, the trailer-mounted "Piggy-Back" forklift will accompany you right to your place of use, opening up unprecedented possibilities in terms of transportation. It can travel sideways, carrying panels up to 40' long, allowing delivery in locations that would typically be considered impossible to reach.

Save time and effort while avoiding potential loading and transport issues; have experienced NMP personnel deliver and unload your order.



Delivery

We will make every attempt to deliver material to the desired location. We may be unable to gain access on tight corners or steep terrain. If the site is deemed inaccessible by our driver, the customer may choose an alternate delivery site within a reasonable proximity. If we are unable to make the delivery, additional charges may be assessed.

The customer is responsible for:

- Determining adequate access for delivery ahead of time.
- Meeting the delivery at the agreed upon time.
- Providing adequate resources (1-4 people as needed) for off loading materials.
- **A charge of \$100 per hour maybe added for deliveries that go beyond their allotted time.**
- Checking the shipment at the time of delivery.
- Verifying material quantities against the shipping/packing list.
- Noting any damage or discrepancies upon the paper work at the time of delivery and notifying Nor-Cal Metal Products within 48 hours of delivery.

Delivery times are usually scheduled one day in advance. Nor-Cal Metal Products will make every effort to make the delivery at the scheduled time. Please be aware that there may be conditions beyond our control such as traffic, mechanical failures, road closures, etc. which may affect our schedule.

Will Call & Loading

Flatbed trailers and trucks are best suited to transport metal roofing materials. These can be loaded from the side with a forklift and tied down in a safe and secure manner.

We are not able to load materials onto vehicles and/or trailers which are not suitable or may be hazardous to load. Please be aware that if we find a vehicle to be inappropriate, we reserve the right to refuse to load your order.

Unacceptable examples include: boat trailers, vans, buses, motor homes, campers and box trailers. Pickup racks which do not have sufficient supports for the weight or are not long enough to support bundles are also unacceptable.

Nor-Cal Metal Products is not responsible to tie down loads nor do we provide any tie down materials. Please bring tie downs to secure your load (string or twine are **not** acceptable for this purpose).

Consider having your order delivered on one of our trucks with a piggy back forklift.



Notes to Designer/Installer

Nor-Cal Metal Products is providing the following details as an aid in design. The details in this guide are not inclusive to all design situations. The designer/installer is responsible for modifications and should take into consideration all aspects of the project including climate conditions, such as, snow and wind, as well as, building code requirements, building design, building usage and maintenance requirements.

Installation should be performed only by qualified installers familiar with metal roofing systems and industry standards. For details not shown in this guide, refer to the Sheet Metal and Air Conditioning Contractors National Association (SMACNA) architectural sheet metal manual for proper design. For manufacturer's weather tightness warranties – all details must be preapproved by Nor-Cal Metal Products technical representative.

The Standard gauge for all products in this guide is 24 gauge and the standard finish is Kynar 500®. We recommend specifying all flashings be the same gauge, color, and finish as the panels to insure long-term durability and color match.

Substrates

Details in the manual are all shown over solid substrate. **MS-200™** can be used over spaced purlins. For solid substrate, **Nor-Cal Metal Products** recommends 5/8" plywood or metal decking.

Underlayment

Minimum underlayment requirements are 30 lb. ASTM rated felt, a synthetic underlayment with Class A and ASTM UV protection technology or a high temperature self-adhering rubberized membrane. When choosing the underlayment, consider the roof slope, roof design, roof panel, and the climate.

Drag Load Requirements

All panels must be pinned at one end to resist the drag load caused by snow loads, live loads, and the weight of the panel. Drag load is a function of roof slope, actual load and length of panels. Contact **Nor-Cal Metal Products** for specific drag load requirements.

Ventilation/Insulation

It is the responsibility of the designer to determine the material types needed to control condensation and to insulate and ventilate the roof system. Applications over rigid insulation may require blocking for solid attachment and framing the perimeter for installation of perimeter flashings.

Oil Canning

Flat metal surfaces will display waviness commonly referred to as “oil canning.” Oil canning is caused by a variety of conditions. Steel mill tolerances, variations in or uneven substrates and roofing underlayments. Oil canning is a characteristic of metal roofing, not a defect and is not a cause for rejection. **Nor-Cal Metal Products** offers **MS-200™** with striations or accent ribs to help minimize oil canning.

Thermal Movement

The Panels and the flashings must be allowed to expand and contract, especially with longer length panels. The panel may need to have a slight gap where the panel hooks the offset cleat to allow for thermal movement of the panels.

Snow Design

The following details do not address all conditions for snow environments. Consult with the designers, engineers, and others for acceptable details to accommodate your project and climate conditions. When possible gutters, valleys, pitch changes or other penetrations should be minimized in snow areas. All roof penetrations should be located as close to the ridge or “pin point” top of roof. Snow country requires special designs for valleys to accommodate accumulation of snow and ice from uphill panels. Roof design should be considered in snow areas. Roof design should help resist the melting and freezing of snow and ice.

A fit for purpose roof design has the greatest impact on maintaining a damage free roof system in snow areas. Please contact a Nor-Cal Metal Products representative for assistance in detail designs and appropriate panel selection for specific climate and building conditions.

Handling / Storage & Safety

Handle materials with care when off-loading or moving materials to avoid damage to panels or flashings. Long panels may require two or more pick-up points, properly spaced to avoid damaging panels. Plan ahead; contact Nor-Cal Metal Products for recommendations on handling/hoisting long panels.

Store the panels, flashings and accessories in a dry, well ventilated area, off the ground. If covering, allow ventilation around panels. Elevate one end of bundle to allow drainage of wet materials.

Wear clean, soft-soled shoes when walking on roofing panels to avoid damage to the painted finish.

Take care that sand, gravel, dirt, etc. sticking to your shoes is not carried onto the roof, scratching or otherwise damaging the finish on the roofing material. Walking on asphalt impregnated felt paper, especially on a hot day, can cause the asphalt to stick to your shoes and be tracked on to the roofing material.

Take care when painting to avoid getting over spray on the roofing material. Remember that wind can carry paint particles some distance. Over spray can cause the finish of the roofing material to look dull and may void your warranty.

Secure materials, especially when leaving the site, on the ground or roof to prevent winds from moving the materials. Wind-blown materials may cause damage to the material, property or persons.

Always use proper safety equipment and attire to minimize risk of cuts or other injuries.

Do not walk on panels that have not been completely installed.

Do not walk on major ribs of panels.

Metal roofs that are wet or dusty can be extremely slippery. Wear soft soled shoes and a safety harness to minimize risk of falling.

Avoid installing metal panels in windy conditions.

Safety considerations are the responsibility of the installer and his crew. Be sure to and **use common sense** generally accepted safety practices when installing roofing materials.

STANDARD EAVE DETAIL

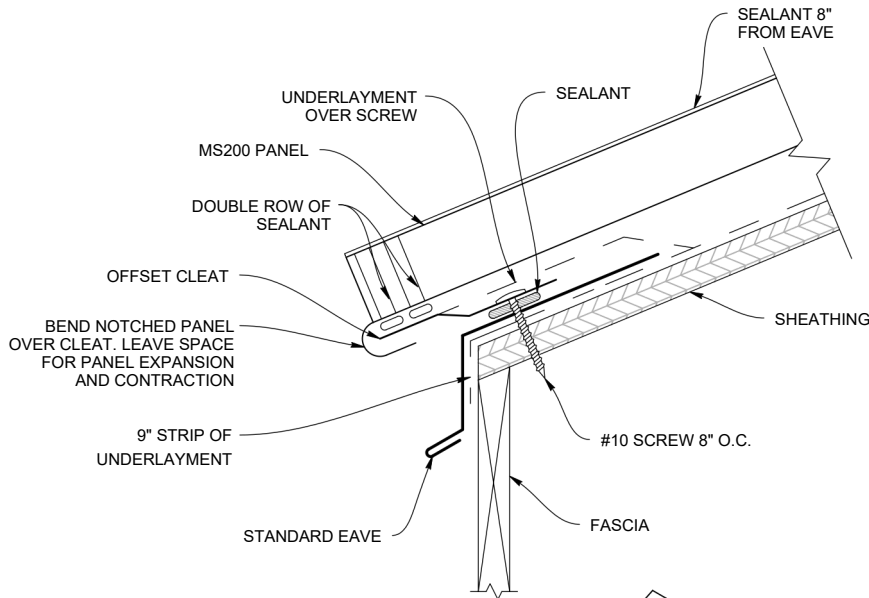

STANDARD EAVE (MS200ES)

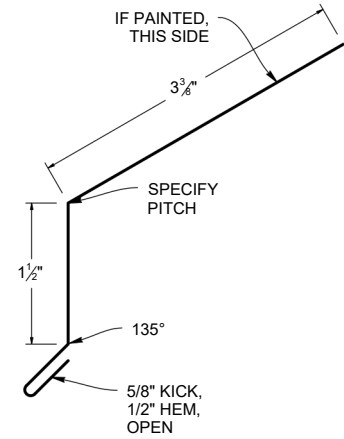

OFFSET CLEAT (MS200OC)

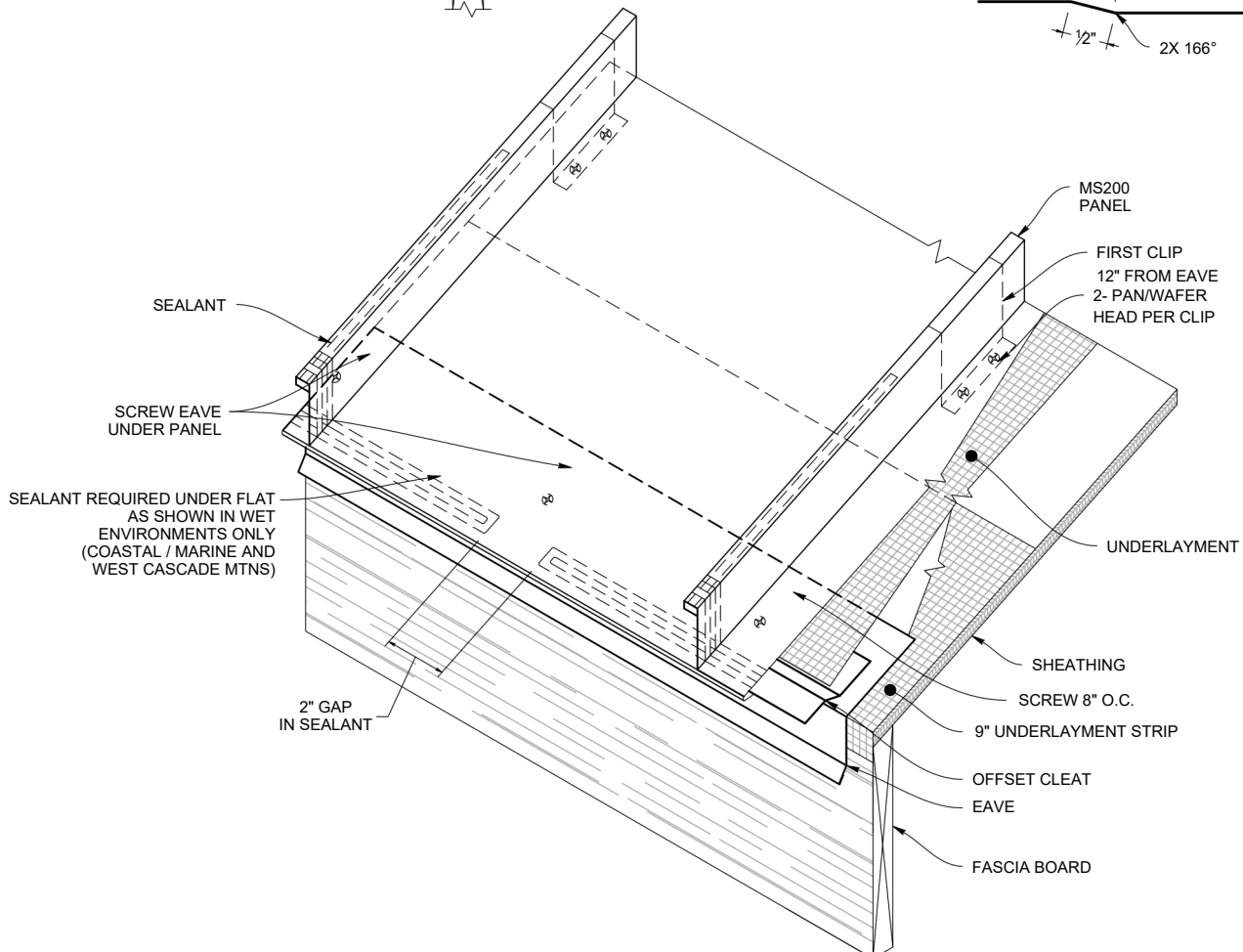
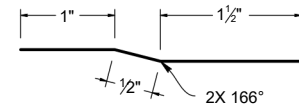

Note: All screws must be fastened into solid substrate.
Flashing must be lapped 4" with 3 rows of gunnable sealant.

HOOK EAVE DETAIL

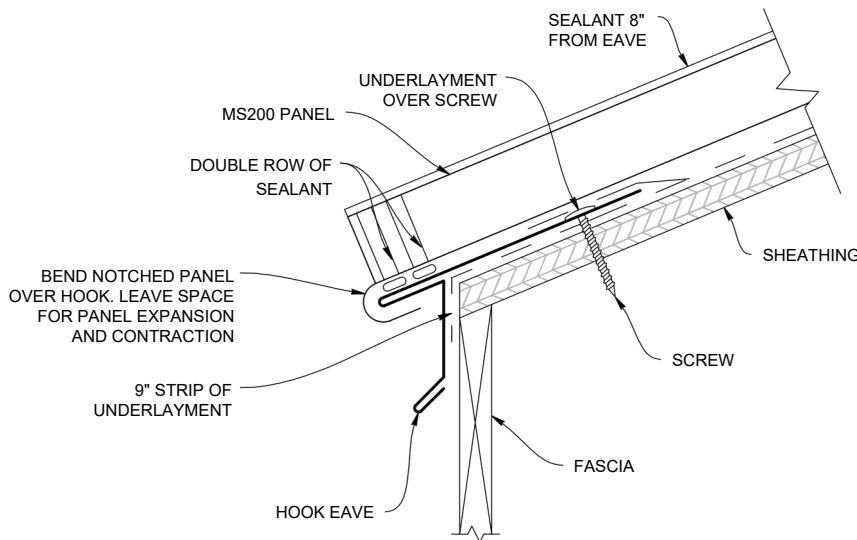

HOOK EAVE (MS200EH)

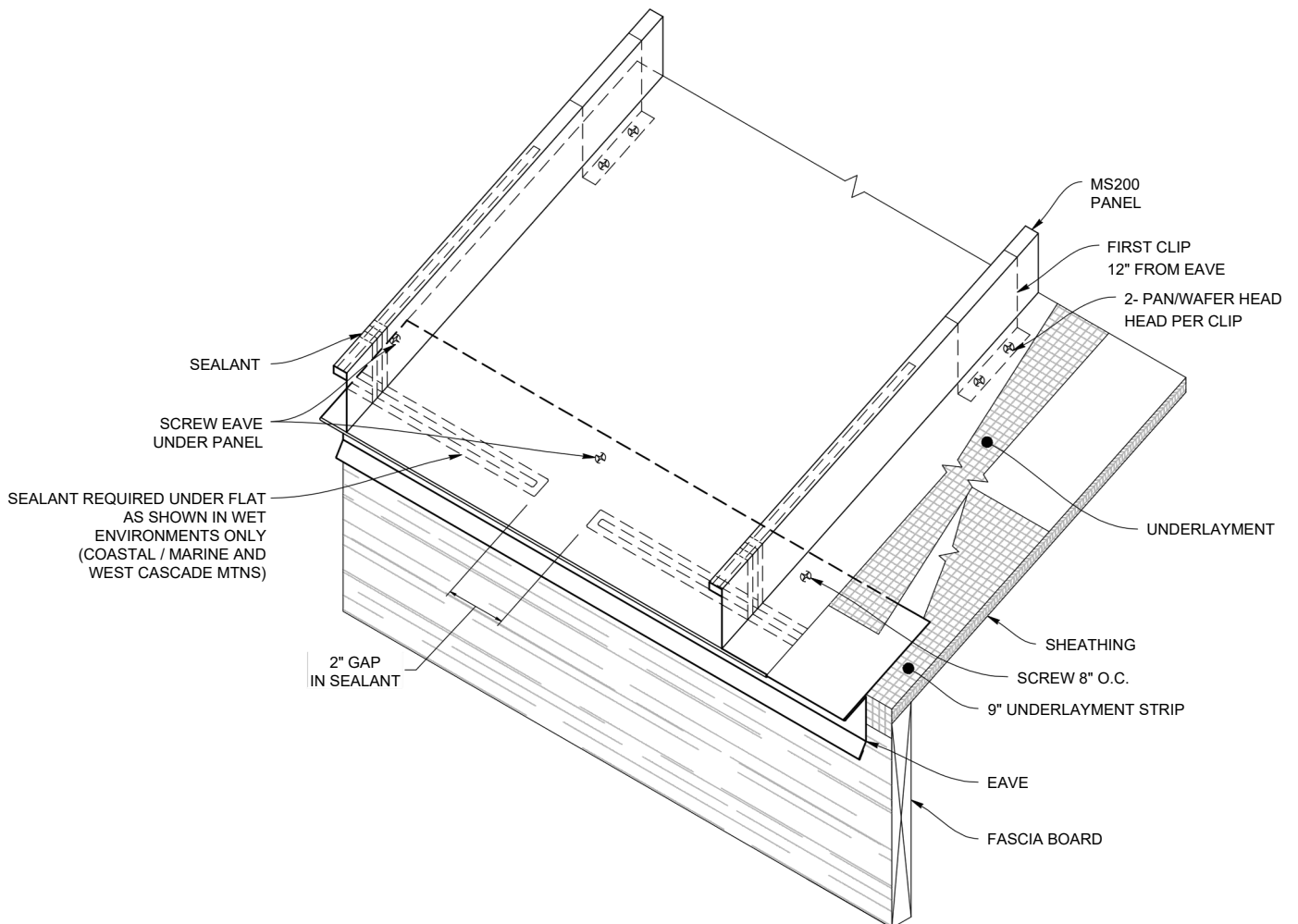
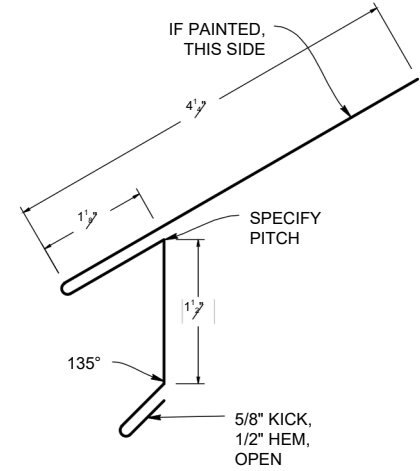

Note: All screws must be fastened into solid substrate.
Flashing must be lapped 4" with 3 rows of gunnable sealant.

HOOK EAVE WITH GUTTER DETAIL

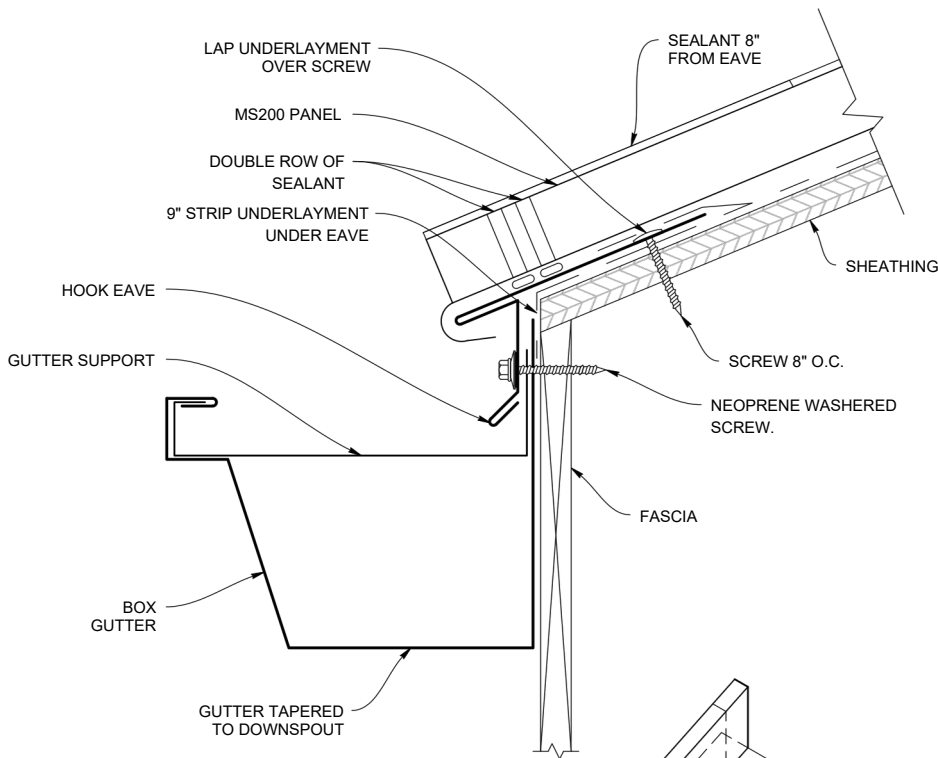

BOX GUTTER (MS20065BG)

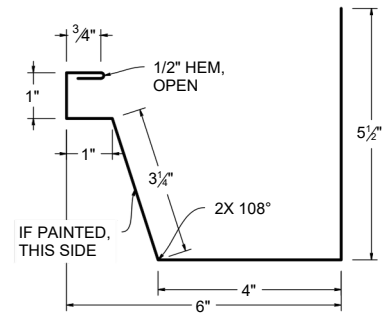

HOOK EAVE (MS200EH)

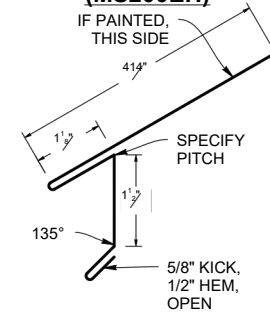

BOX GUTTER HANGER (AGH6)

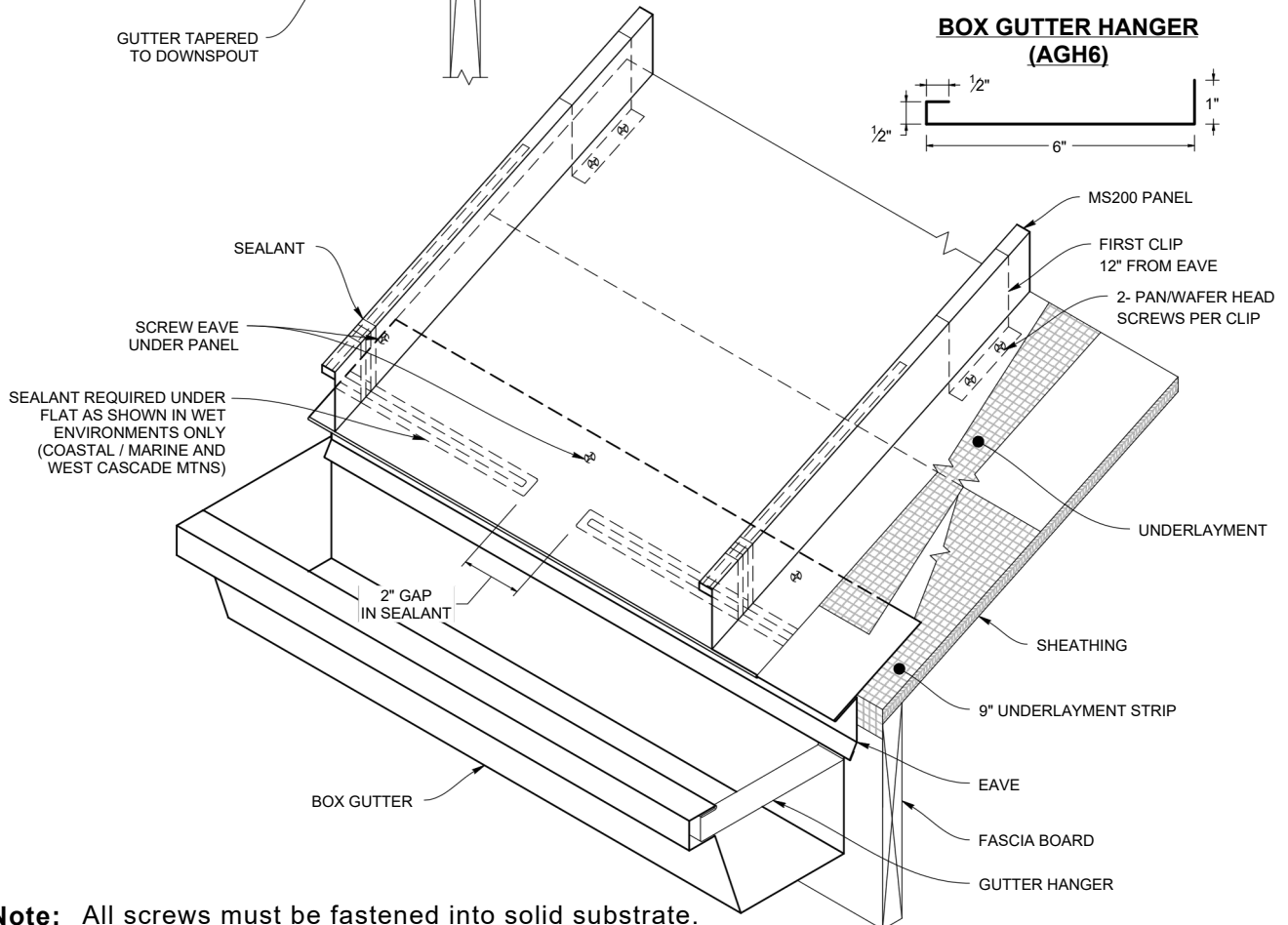
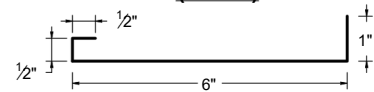

Note: All screws must be fastened into solid substrate. Flashing must be lapped 4" with 3 rows of gunnable sealant.

STANDARD RIDGE DETAIL

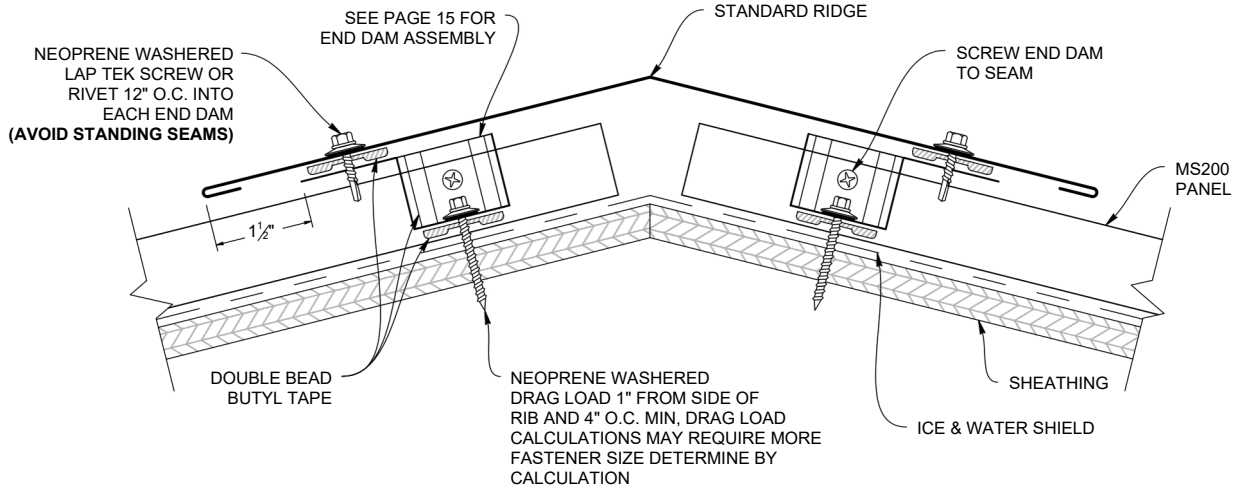

STANDARD RIDGE (MS200RS)

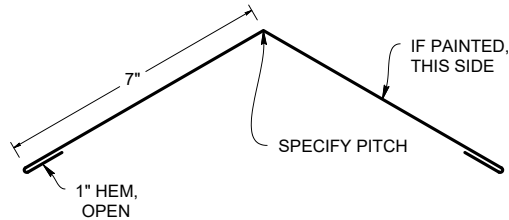

STANDARD RIDGE LAP

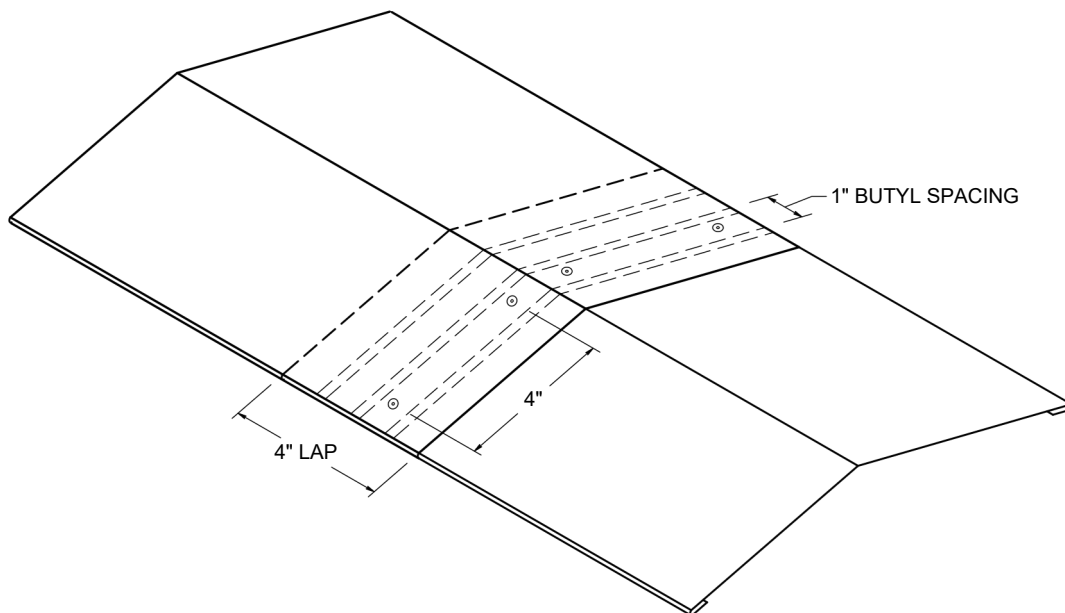

Note: All screws must be fastened into solid substrate. Flashing must be lapped 4" with 3 rows of gunnable sealant.

WT VENTED RIDGE DETAIL

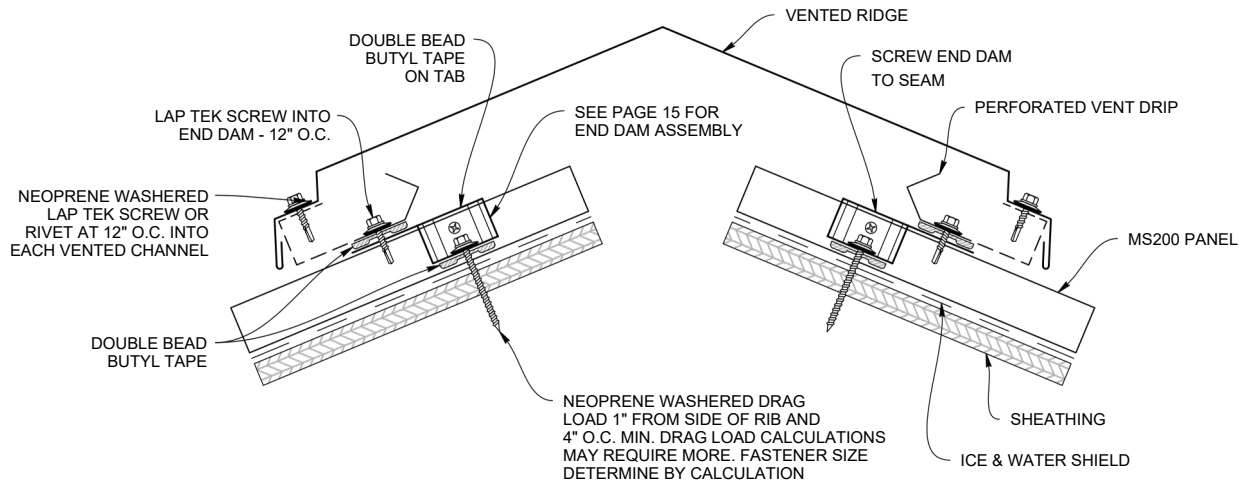

WT RIDGE FULL VENTED (MS200WTRFV)

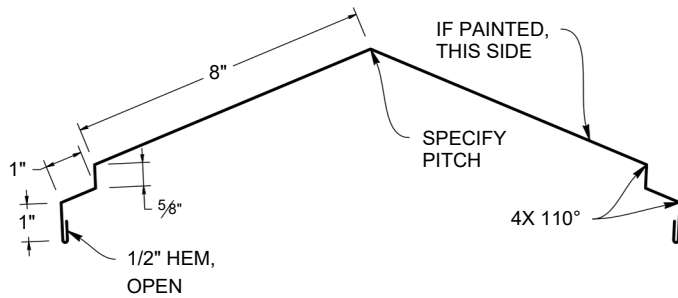

PERFORATED VENT DRIP: E2886 EMBER RESISTANT (MS200PVD)

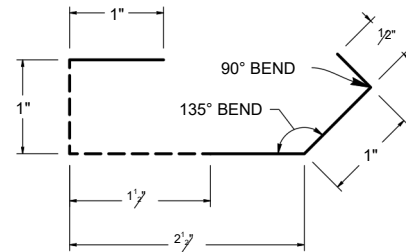

****NOTE: PERFORATED VENT DRIP IS COMPATIBLE WITH WT VENTED RIDGE ONLY****

****14.5" Freeairper LFT for Ridge****

VENTED RIDGE LAP

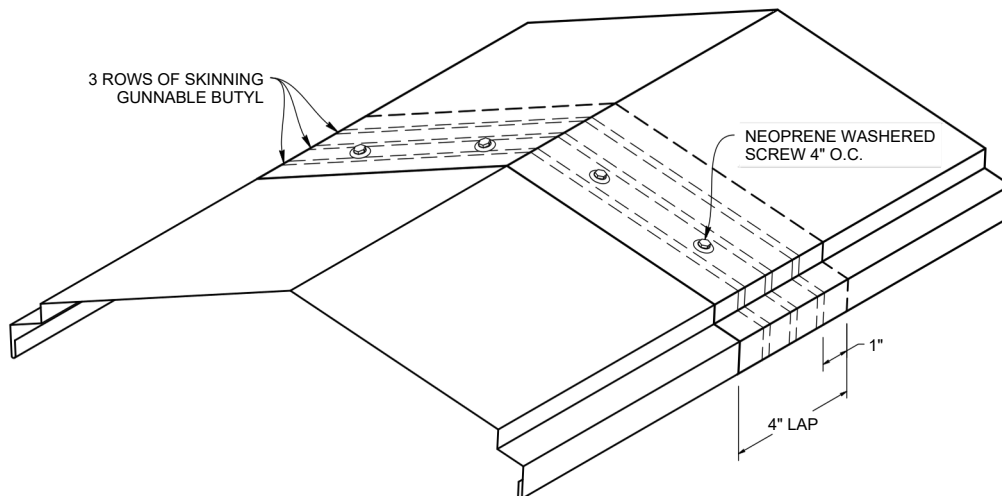

Note: All screws must be fastened into solid substrate.
Flashing must be lapped 4" with 3 rows of gunnable sealant.

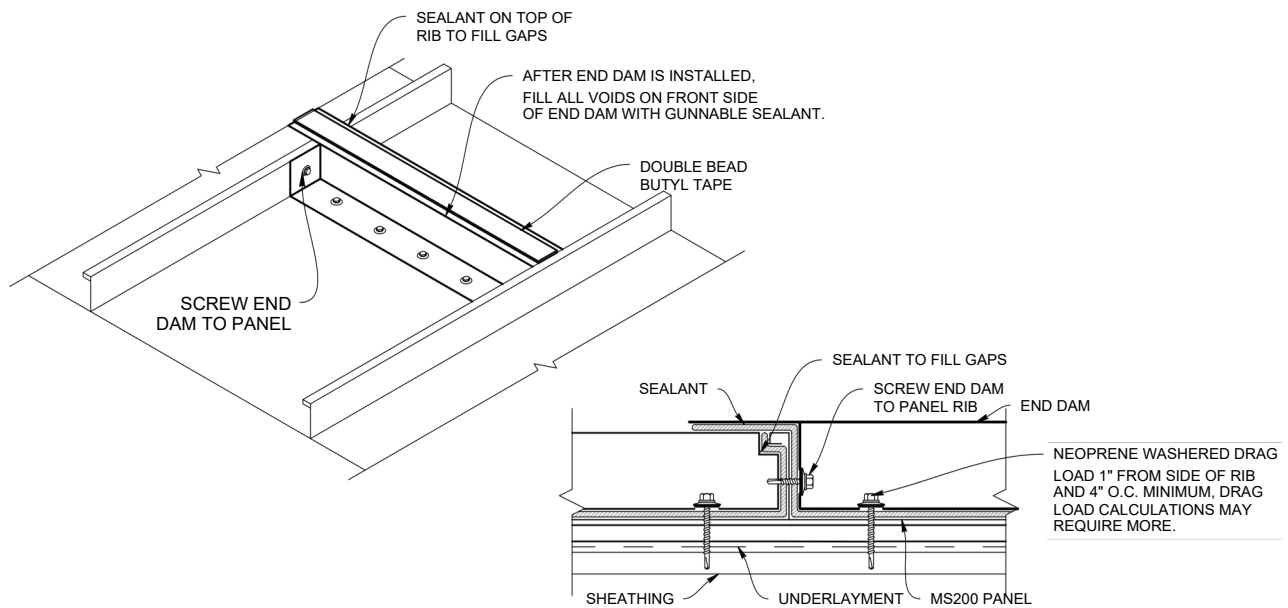
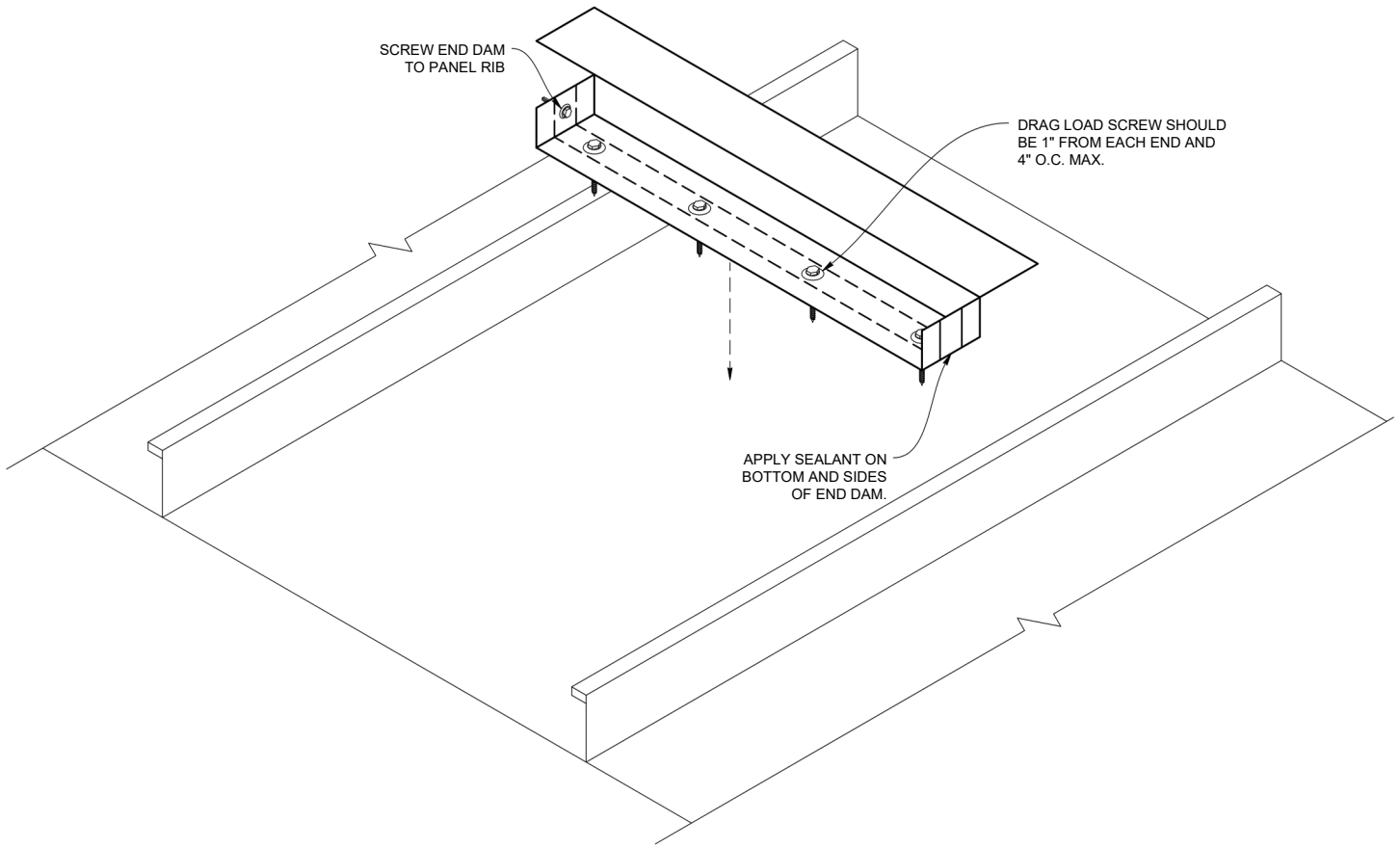

Note: All screws must be fastened into solid substrate.
Flashing must be lapped 4" with 3 rows of gunnable sealant.

VALLEY 24" FLASHING (MS200VF)

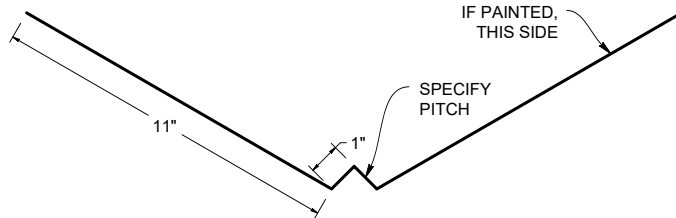

OFFSET CLEAT (MS200OC)

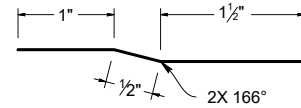

VALLEY 24" DETAIL (3:12 Or Greater Pitch)

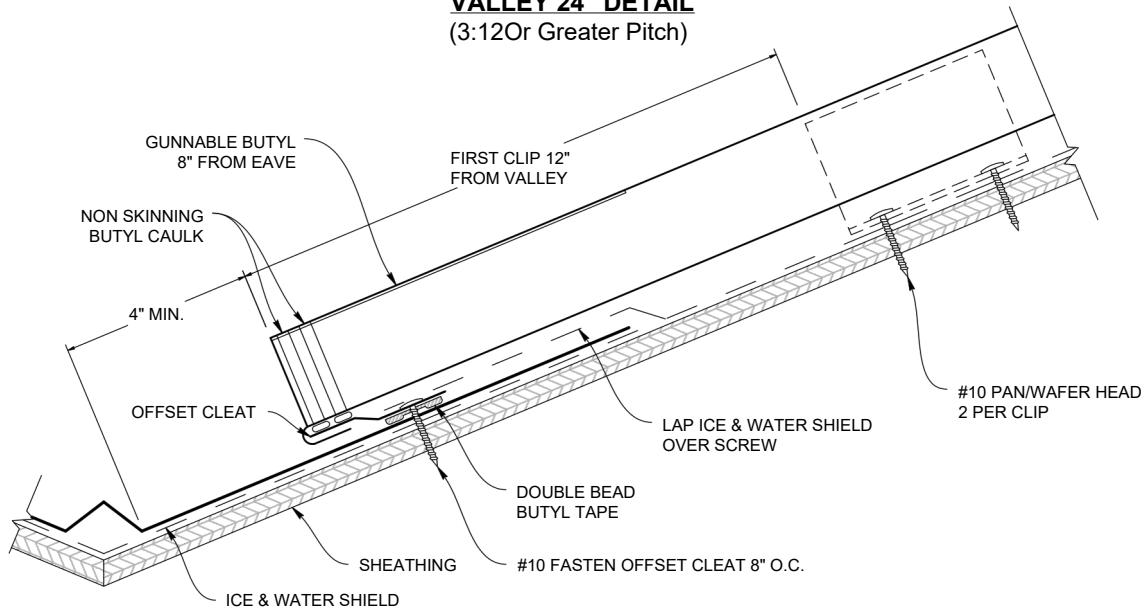

VALLEY LAP (3:12 Or Greater Pitch)

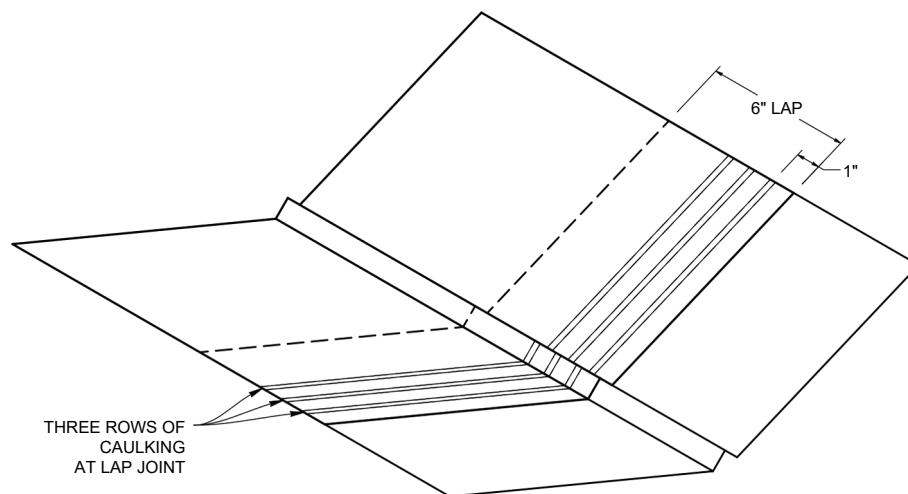

Note: All screws must be fastened into solid substrate.
Flashing must be lapped 4" with 3 rows of gunnable sealant.

LOW SLOPE VALLEY DETAIL (Less Than 3 :12 Pitch)

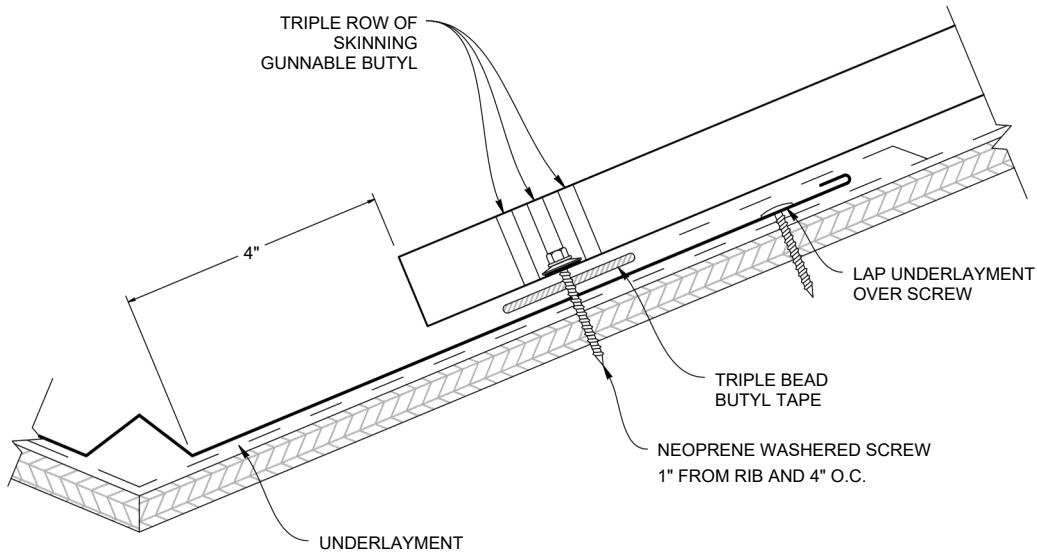

VALLEY FLASHING (MS200VF)

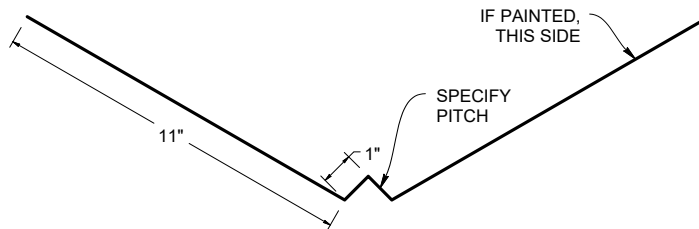

LOW SLOPE VALLEY LAP (Less Than 3 :12 Pitch)

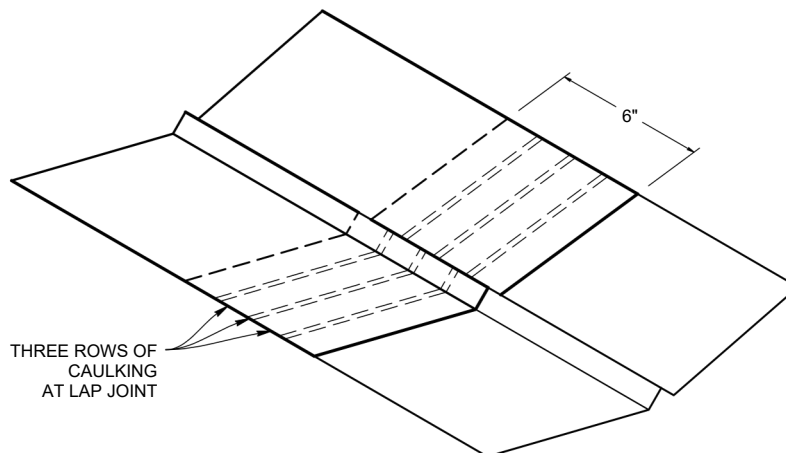

Note: All screws must be fastened into solid substrate.
Flashing must be lapped 4" with 3 rows of gunnable sealant.

BOX GABLE DETAIL

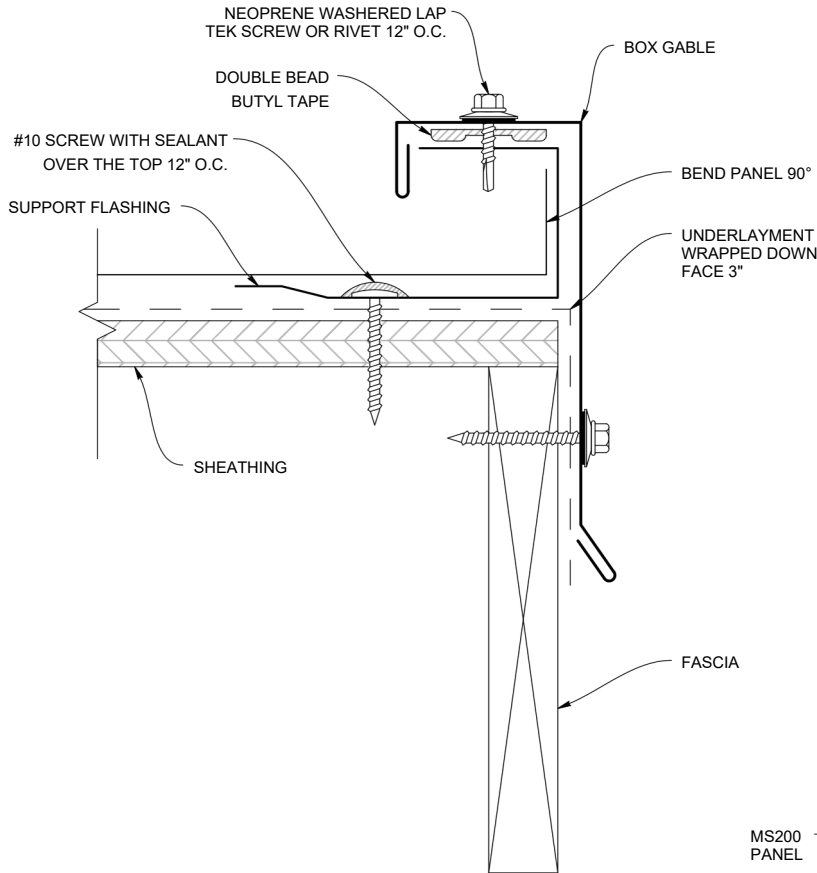

BOX GABLE FLASHING (MS200GB)

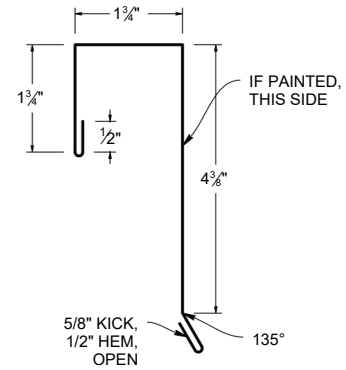

SUPPORT FLASHING (MS200SF)

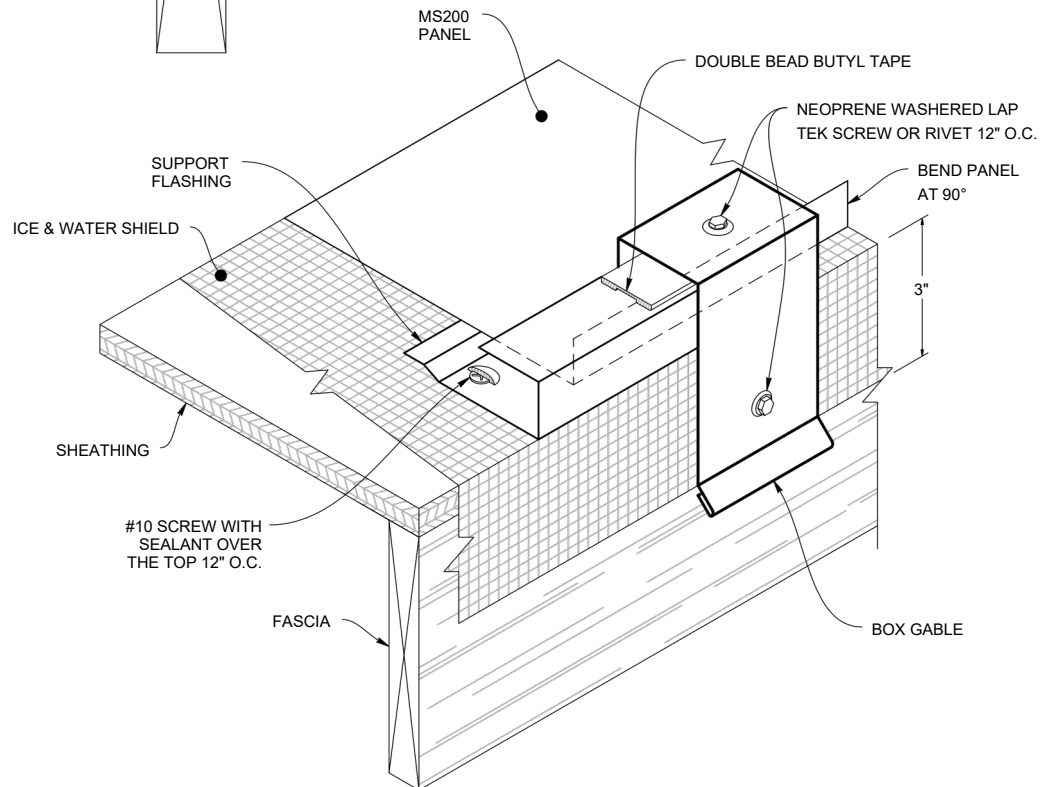
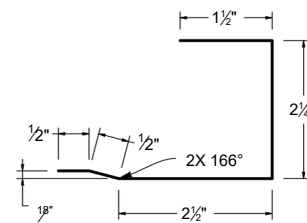

Note: All screws must be fastened into solid substrate.
Flashing must be lapped 4" with 3 rows of gunnable sealant.

ALTERNATE GABLE DETAIL

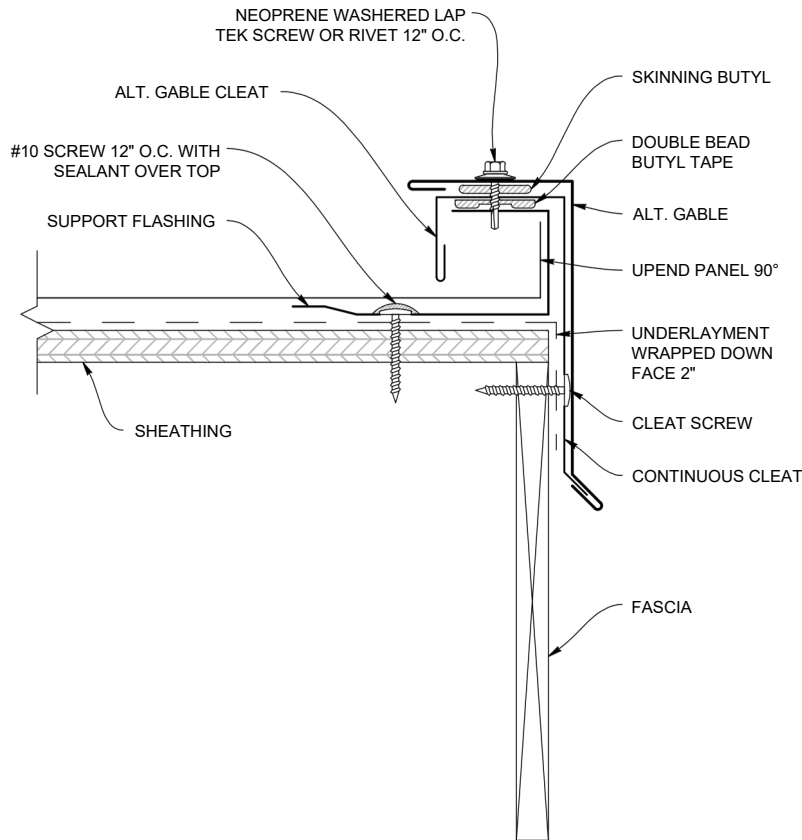

ALTERNATE GABLE (MS200AG)

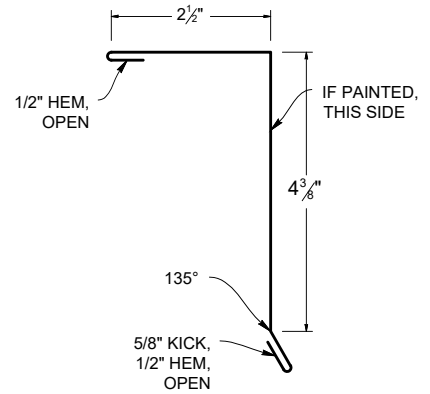

ALTERNATE GABLE CLEAT (MS200AGT)

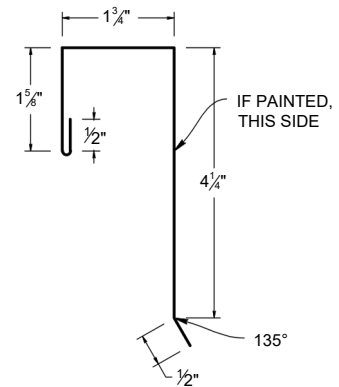

SUPPORT FLASHING (MS200SF)

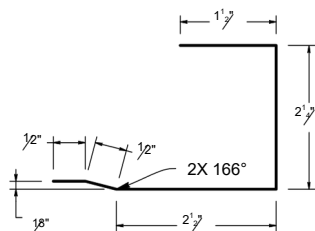

Note: All screws must be fastened into solid substrate.
Flashing must be lapped 4" with 3 rows of gunnable sealant.

SIDEWALL DETAIL

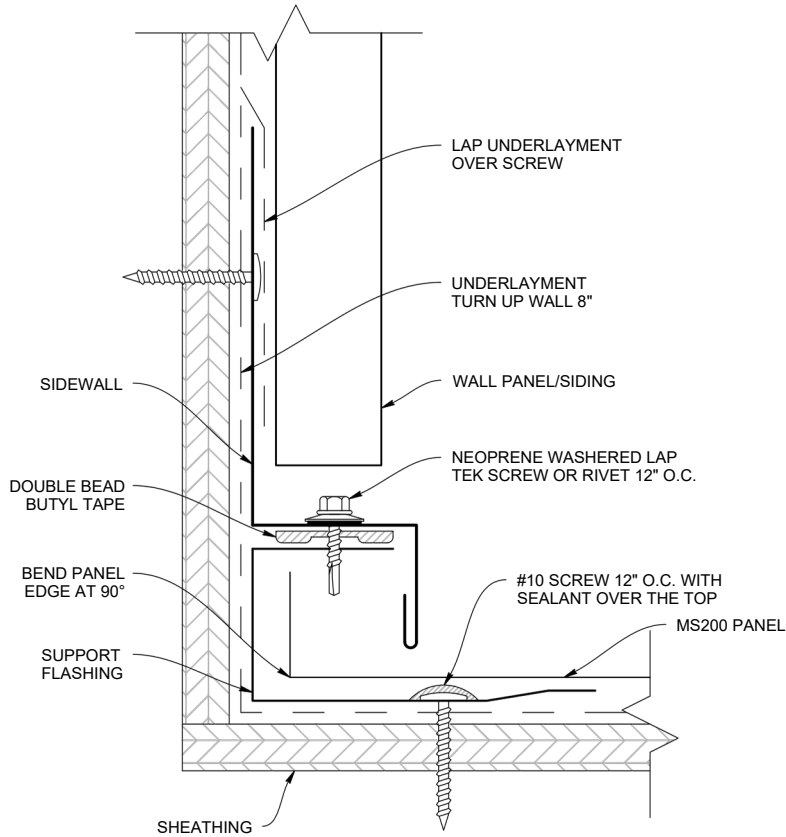

SIDEWALL (MS200SW)

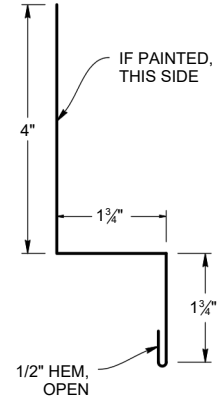

SUPPORT FLASHING (MS200SF)

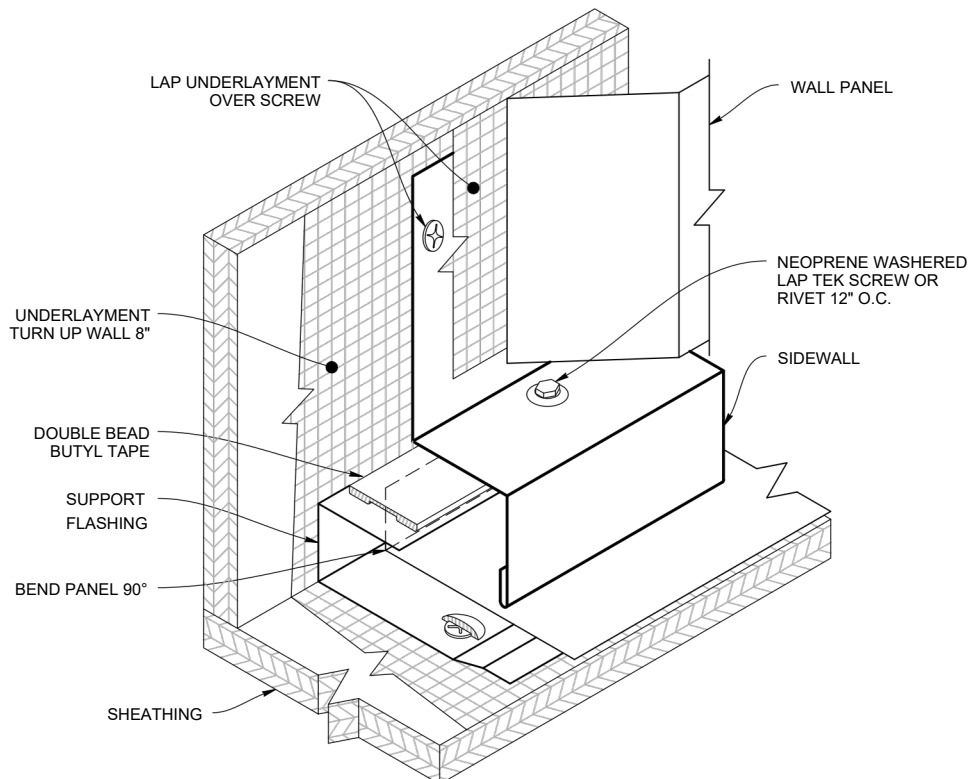
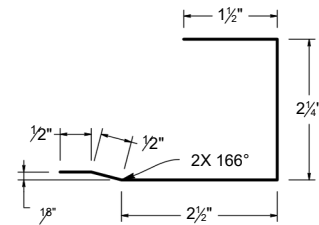

Note: All screws must be fastened into solid substrate.
Flashing must be lapped 4" with 3 rows of gunnable sealant.

PEAK FLASHING DETAIL (Ridge End Cap)

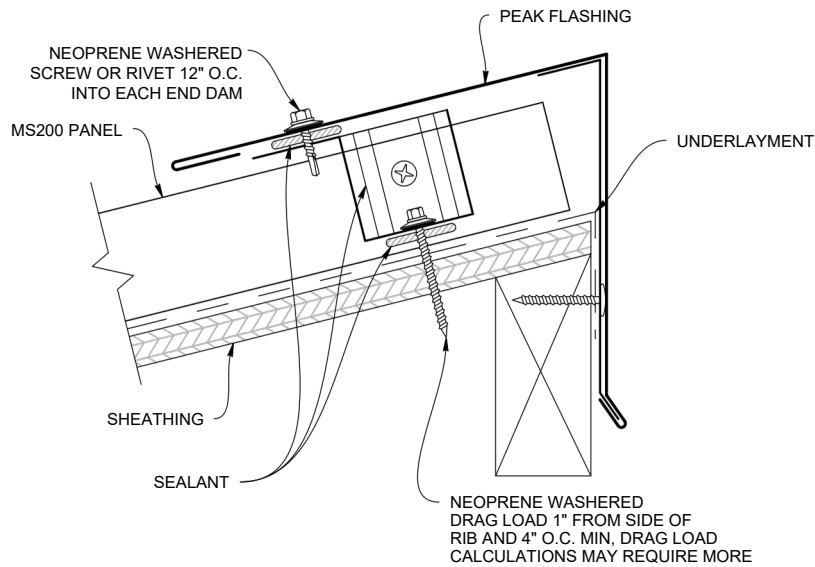

PEAK FLASHING (Ridge End Cap) (MS200REC)

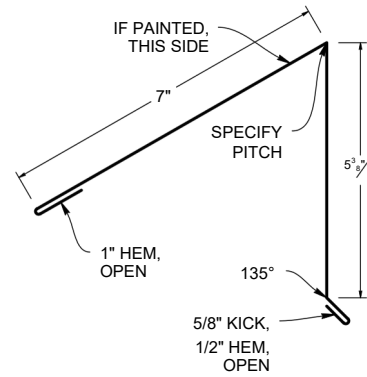

PEAK CLEAT (MS200RECC)

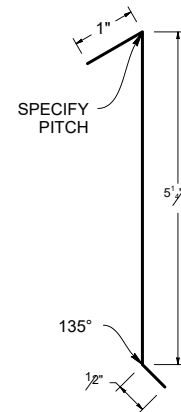

PEAK FLASHING LAP

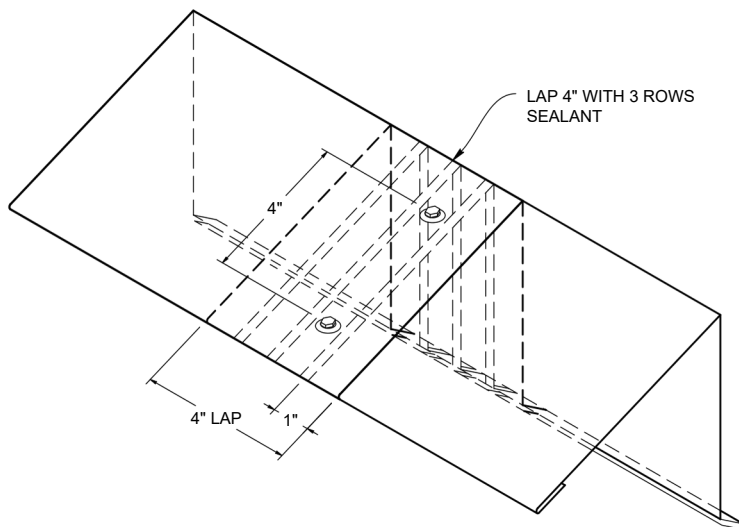

Note: All screws must be fastened into solid substrate.
Flashing must be lapped 4" with 3 rows of gunnable sealant.

WT VENTED PEAK FLASHING DETAIL (Vented Ridge End Cap)

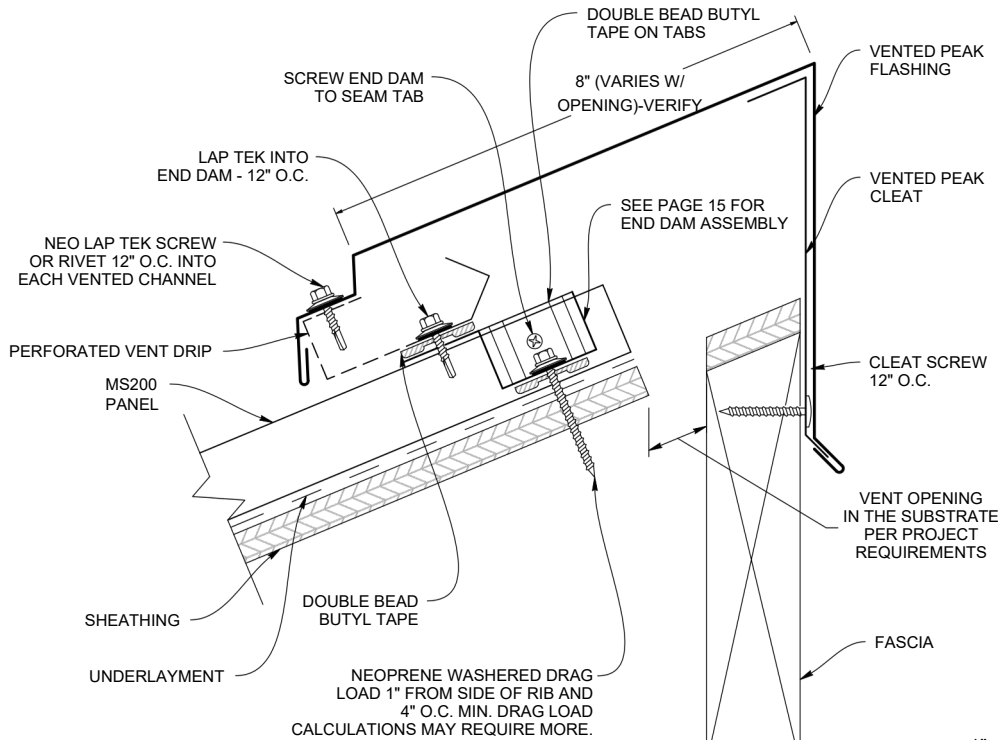

VENTED PEAK CLEAT (MS200VRECC)

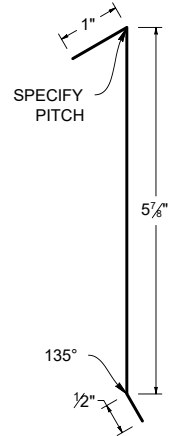

WT VENTED PEAK FLASHING (MS200WTRECV)

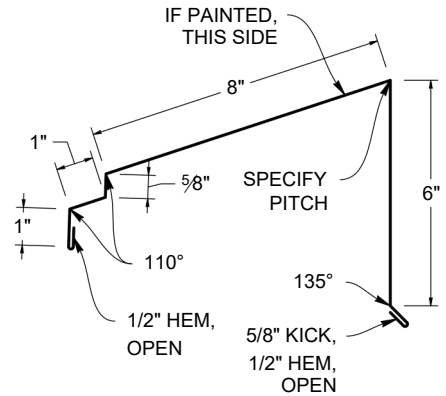

VENTED PEAK FLASHING LAP

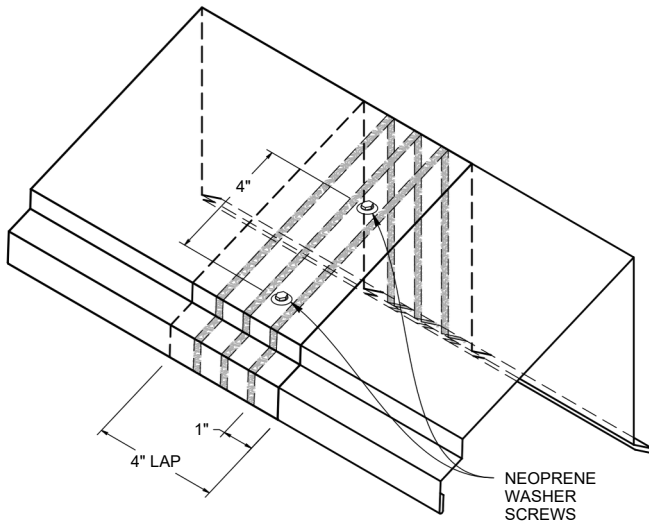

PERFORATED VENT DRIP: E2886 EMBER RESISTANT (MS200PVD)

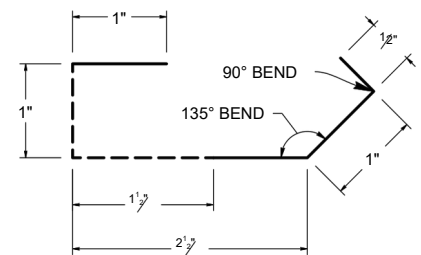

Note: All screws must be fastened into solid substrate.
Flashing must be lapped 4" with 3 rows of gunnable sealant.

NOTE: PERFORATED VENT DRIP IS COMPATIBLE WITH WT VENTED PEAK FLASHING ONLY

**7.25" Freeairper
LFT for Ridge**

PITCH CHANGE DETAIL

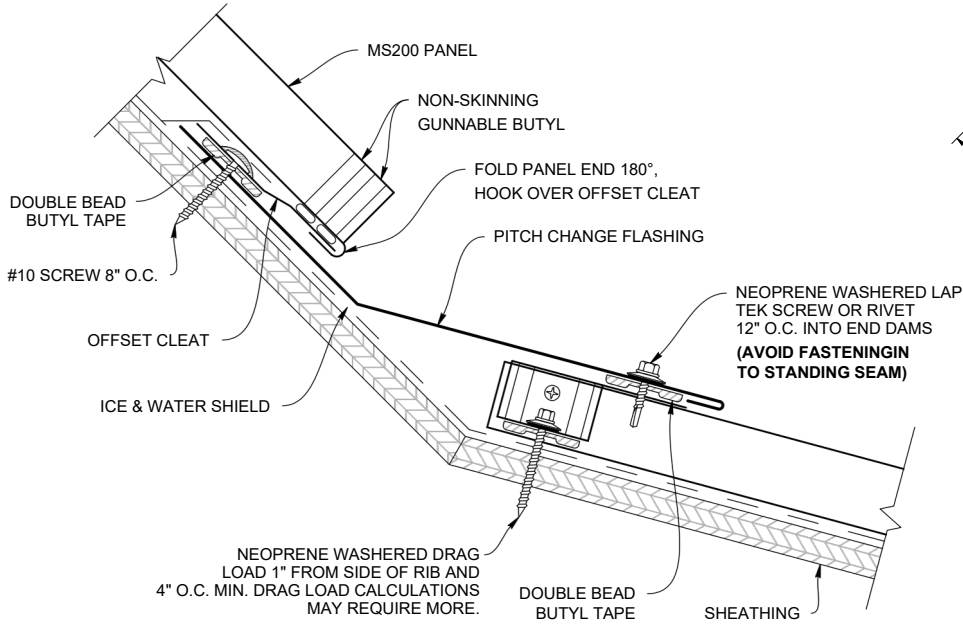

INSIDE PITCH CHANGE FLASHING

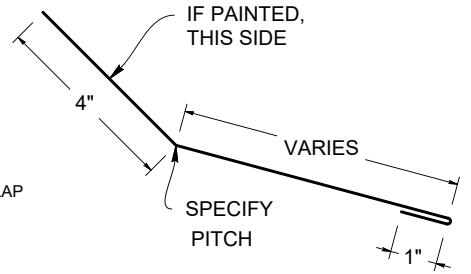

OFFSET CLEAT (MS200C)

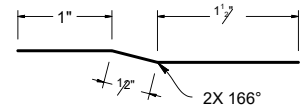

PITCH CHANGE LAP

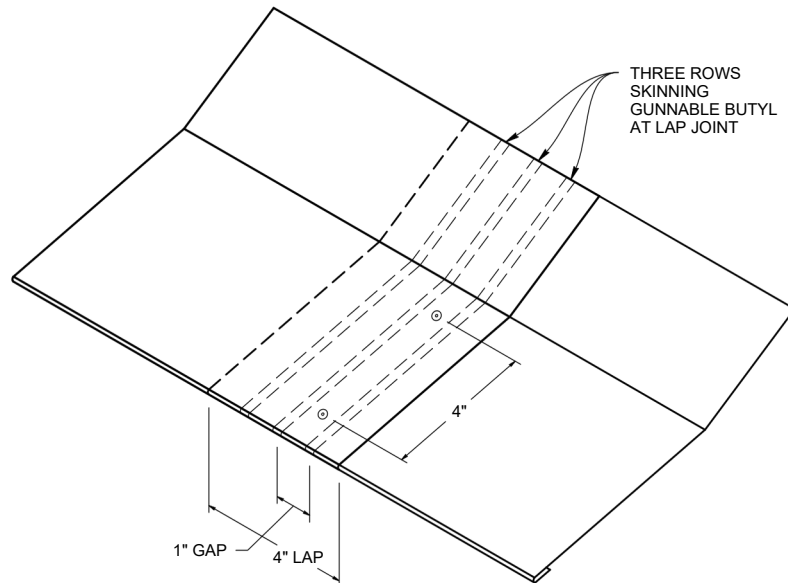

Note: All screws must be fastened into solid substrate.
Flashing must be lapped 4" with 3 rows of gunnable sealant.

ENDWALL DETAIL

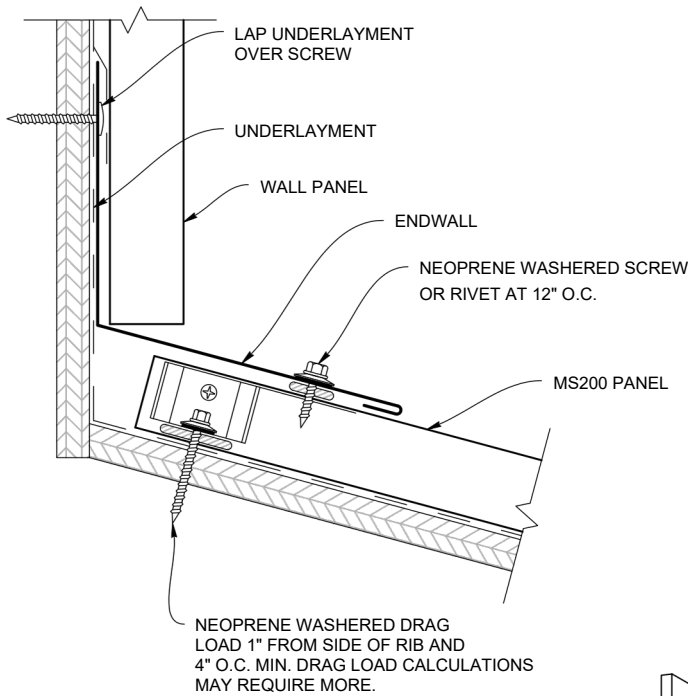

ENDWALL FLASHING (MS200EW)

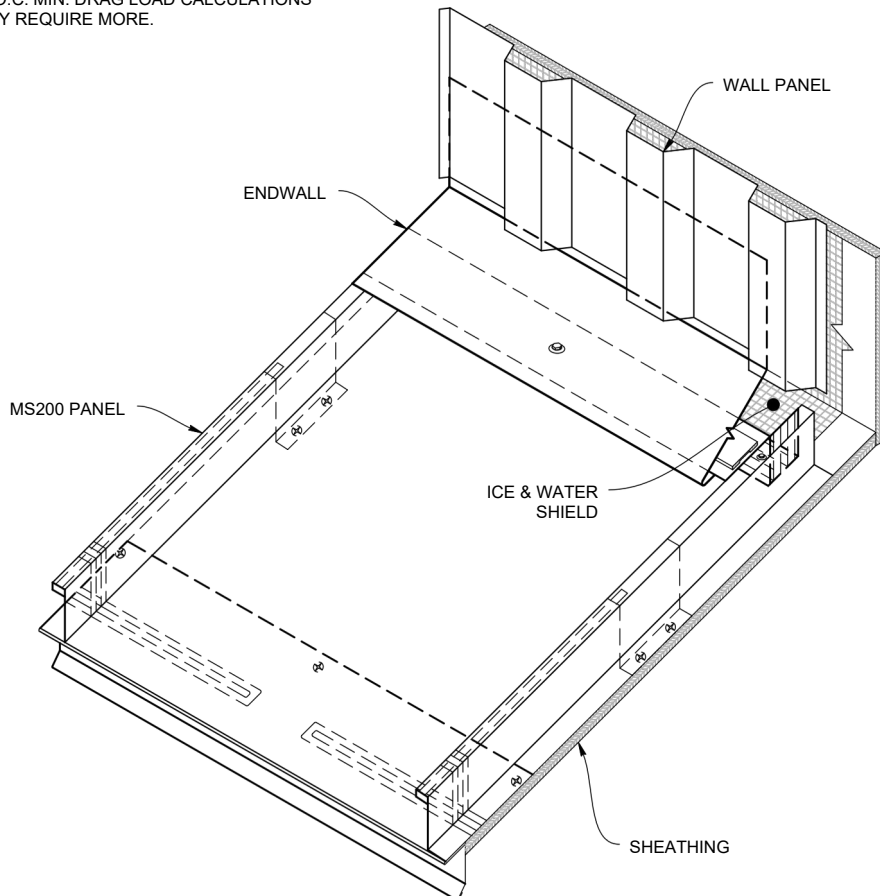
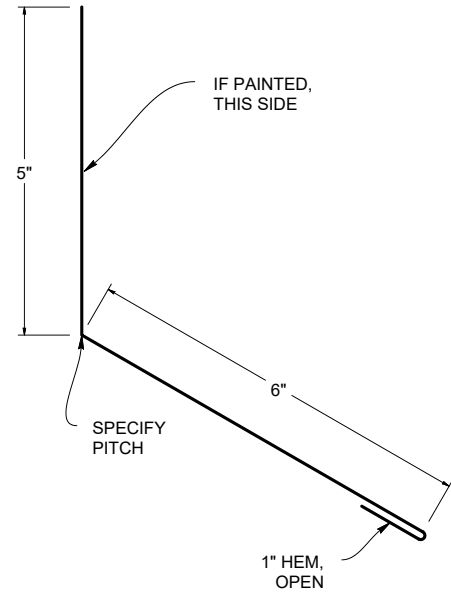

Note: All screws must be fastened into solid substrate.
Flashing must be lapped 4" with 3 rows of gunnable sealant.

WT VENTED ENDWALL DETAIL

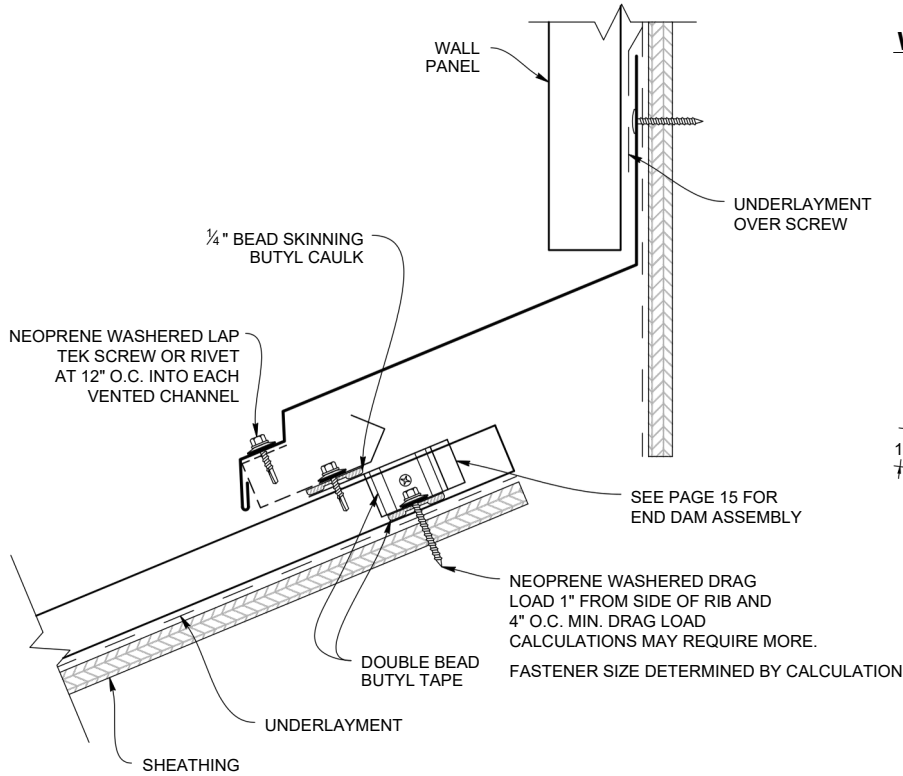

WT VENTED ENDWALL FLASHING (MS200WTEWV)

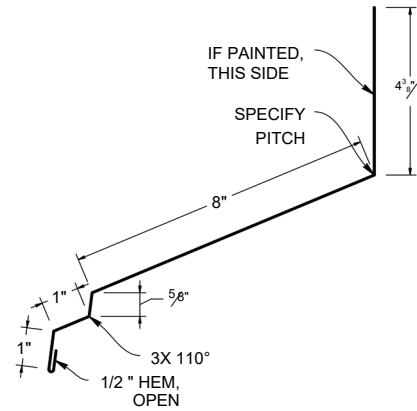

PERFORATED VENT DRIP: E2886 EMBER RESISTANT (MS200PVD)

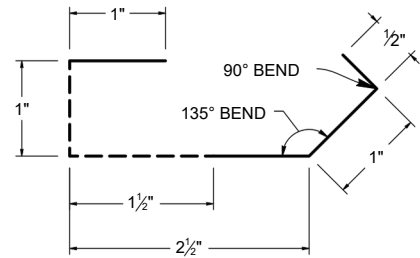

****NOTE: PERFORATED VENT DRIP IS COMPATIBLE WITH WT VENTED ENDWALL ONLY****

****7.25" Freeairper LFT for Ridge****

VENTED ENDWALL LAP

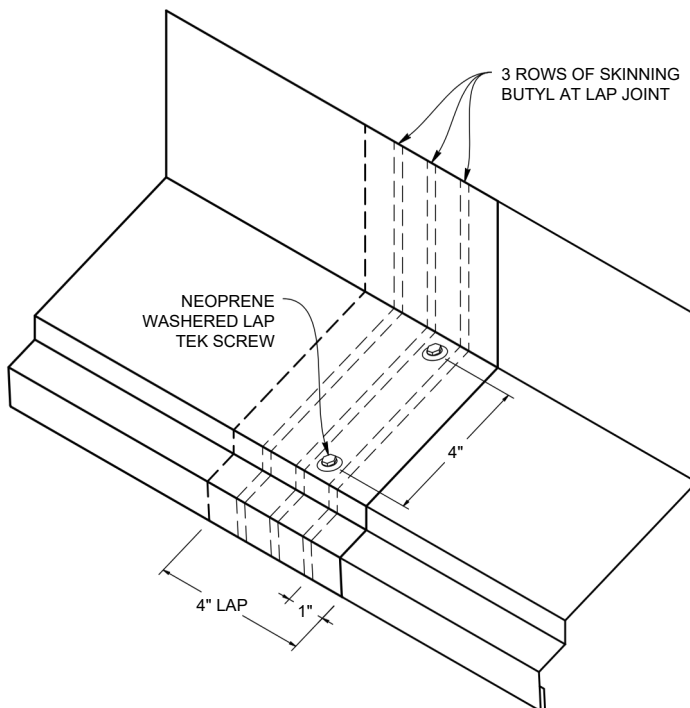

Note: All screws must be fastened into solid substrate.
Flashing must be lapped 4" with 3 rows of gunnable sealant.

SAW CUT ENDWALL DETAIL

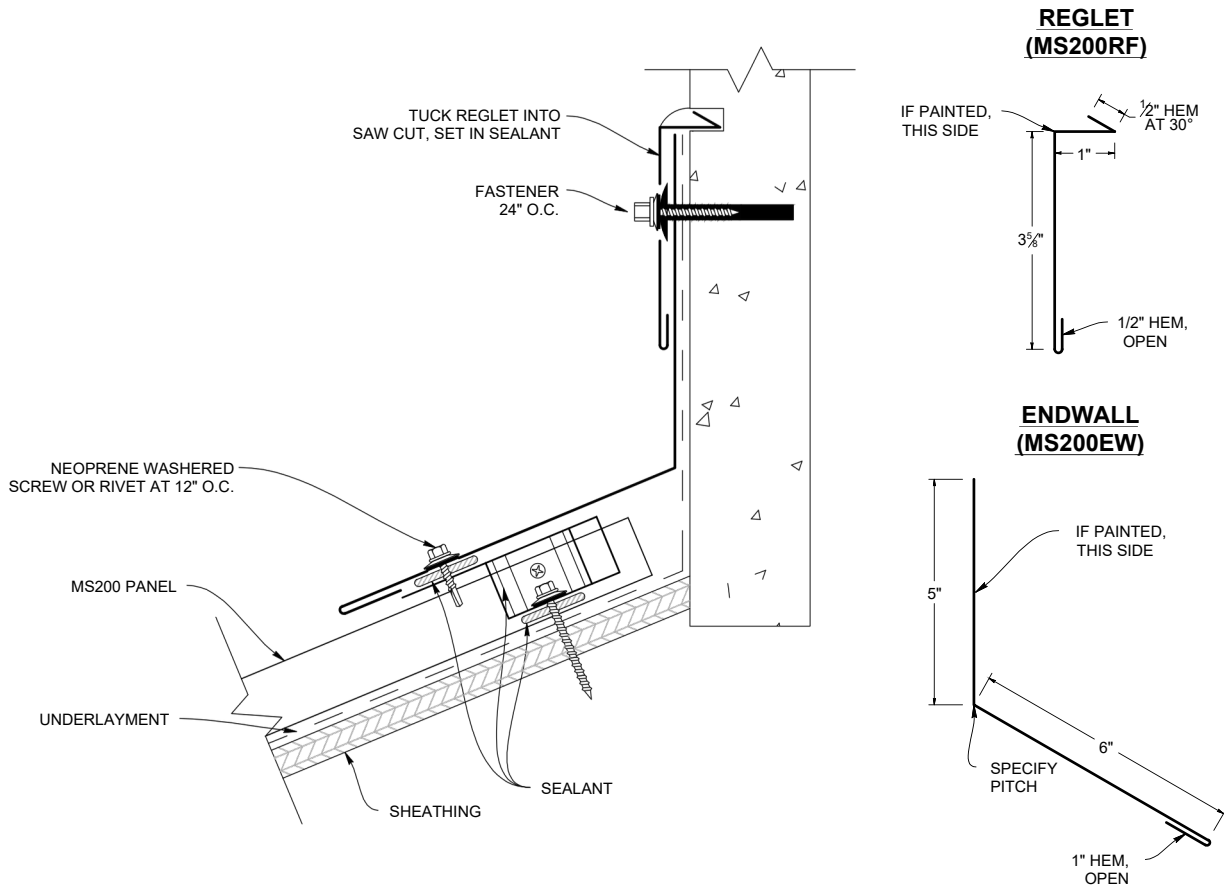

END DAM DETAIL

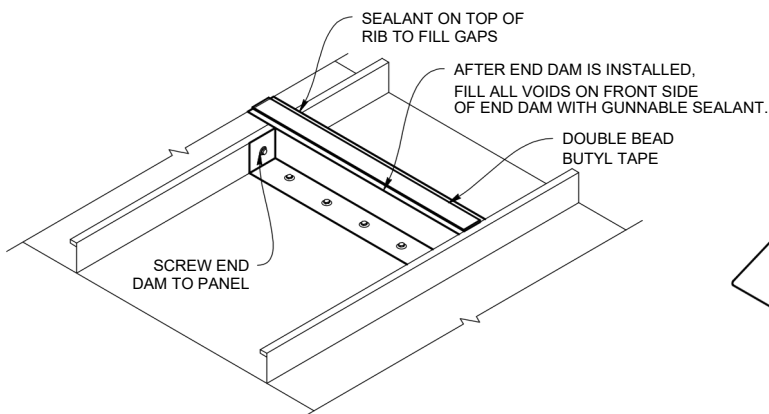

ENDWALL LAP

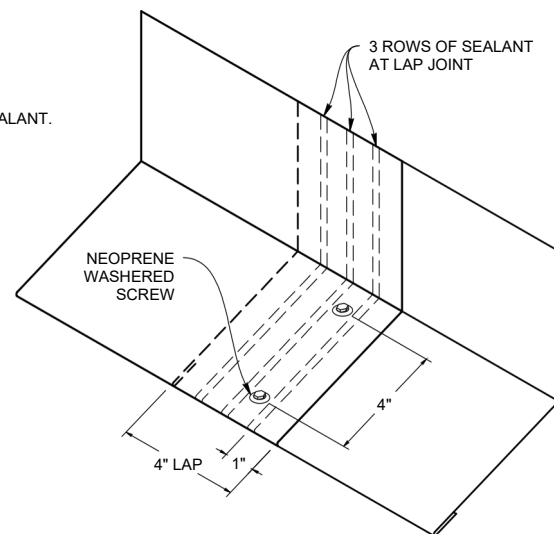

Note: All screws must be fastened into solid substrate.
Flashing must be lapped 4" with 3 rows of gunnable sealant.

STEP 1

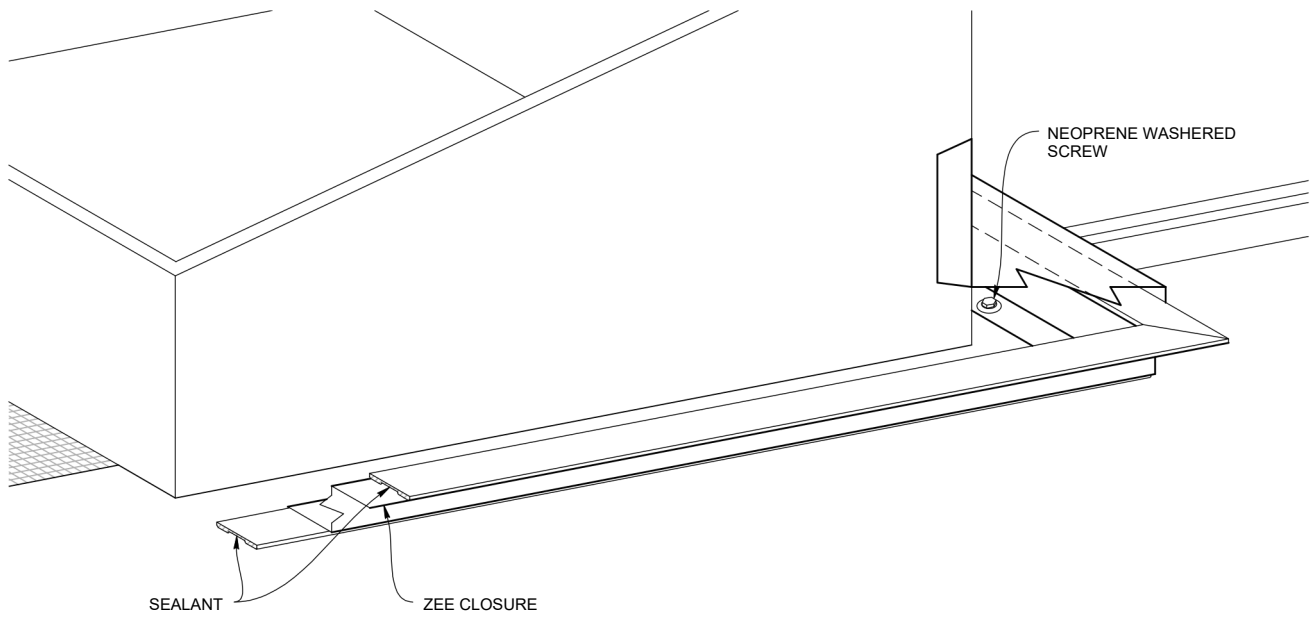

STEP 2

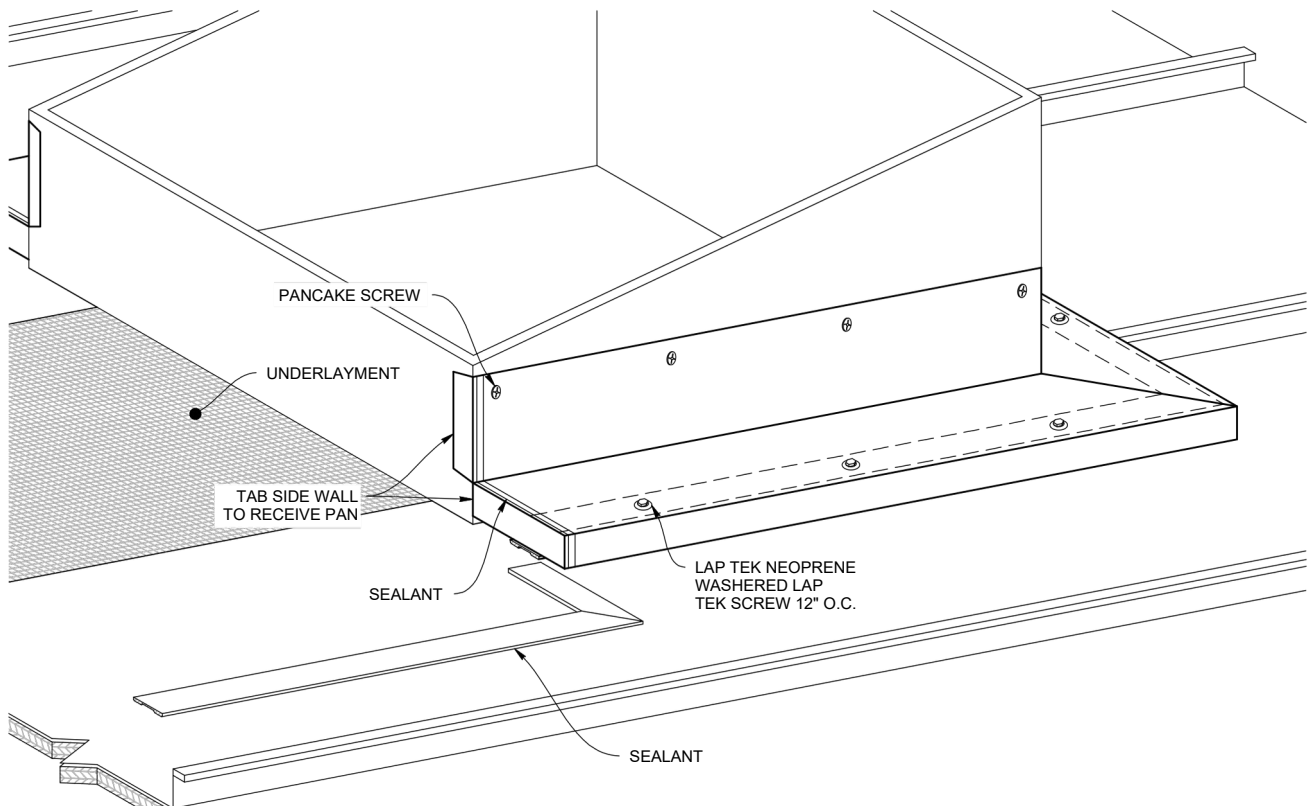

Note: All screws must be fastened into solid substrate.
Flashing must be lapped 4" with 3 rows of gunnable sealant.

STEP 3

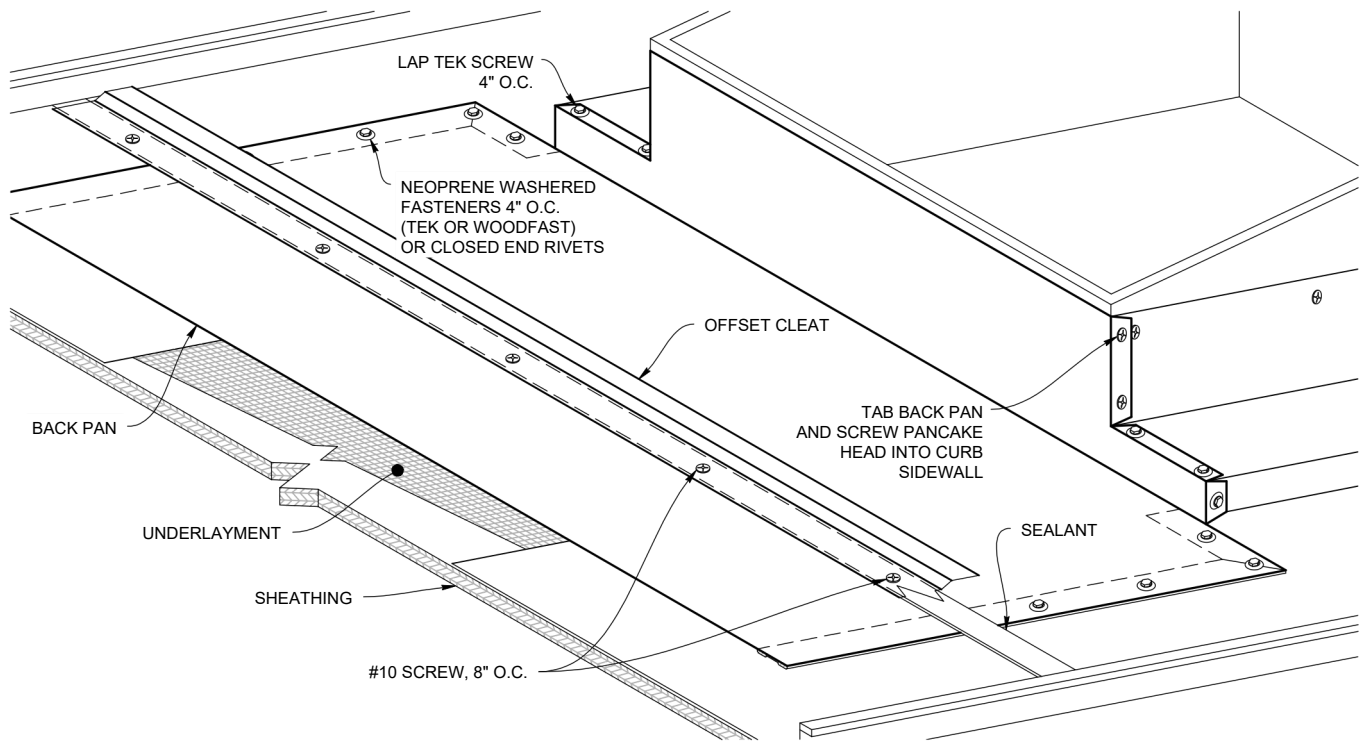

STEP 4

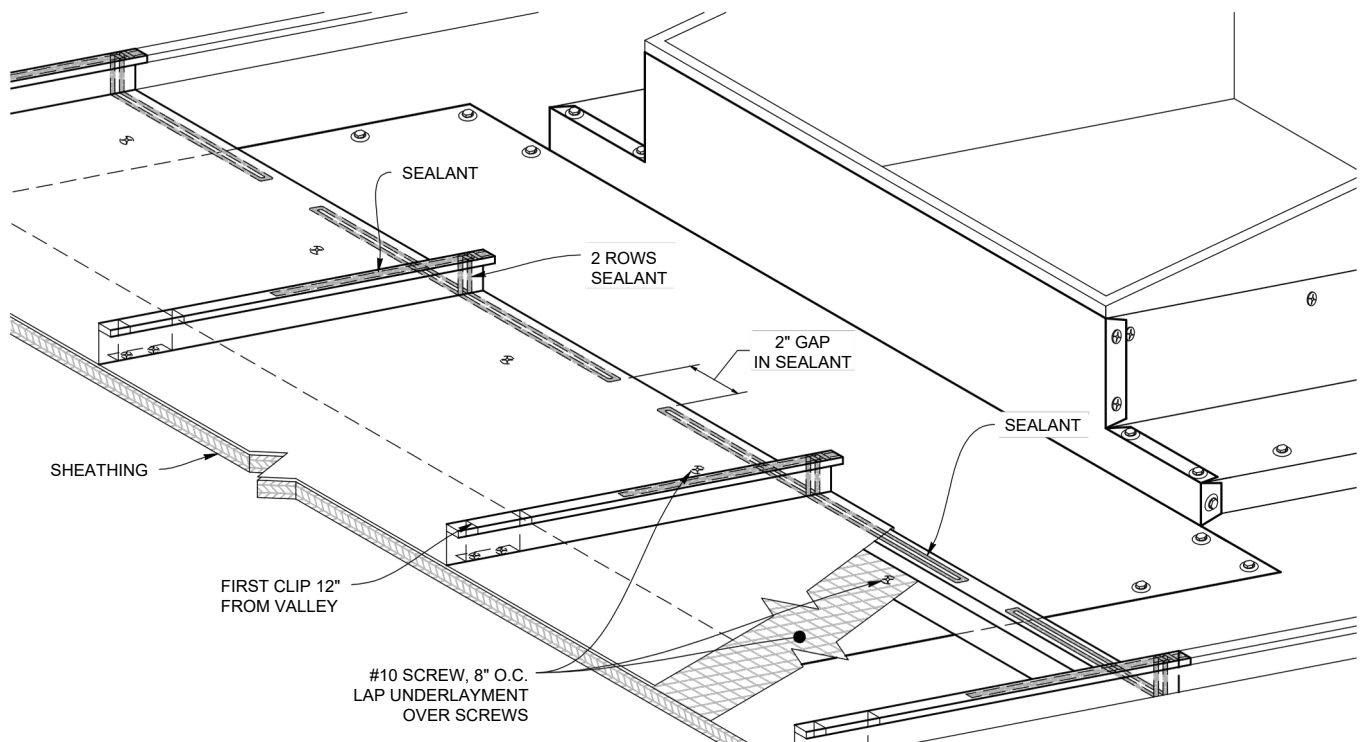

Note: All screws must be fastened into solid substrate.
Flashing must be lapped 4" with 3 rows of gunnable sealant.

STEP 5

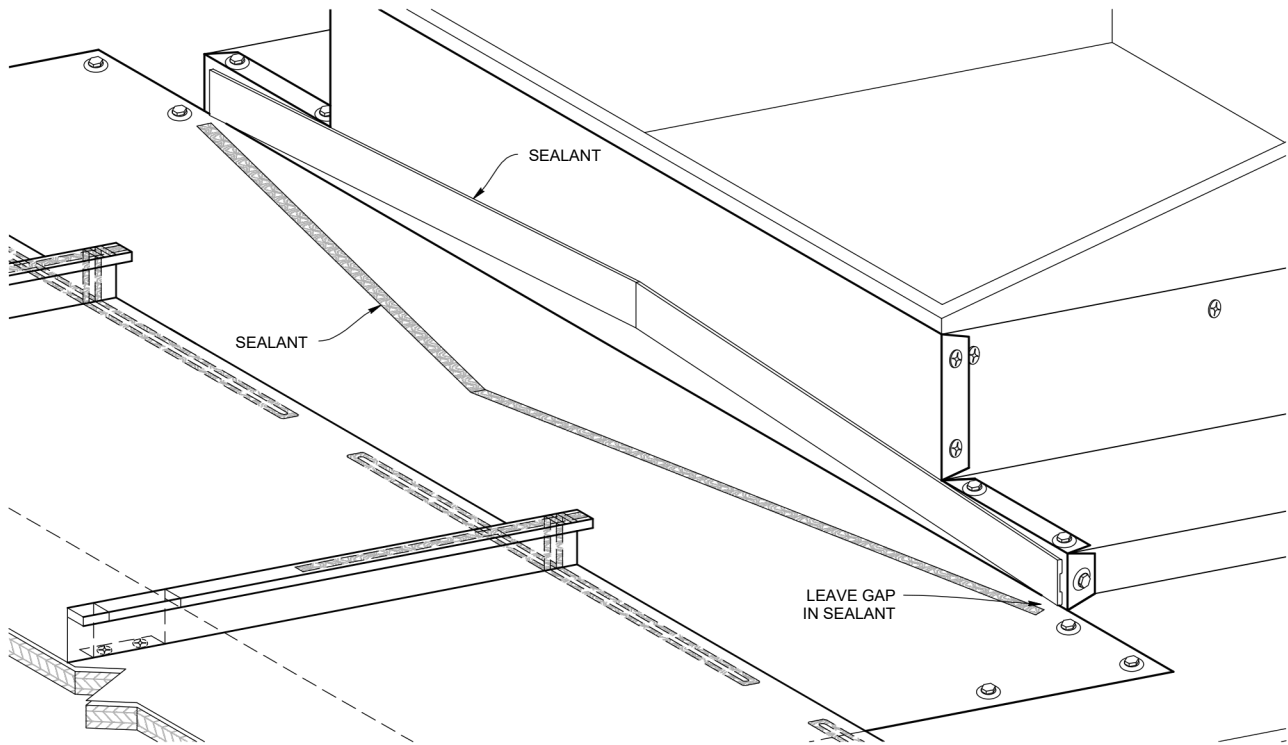

STEP 6

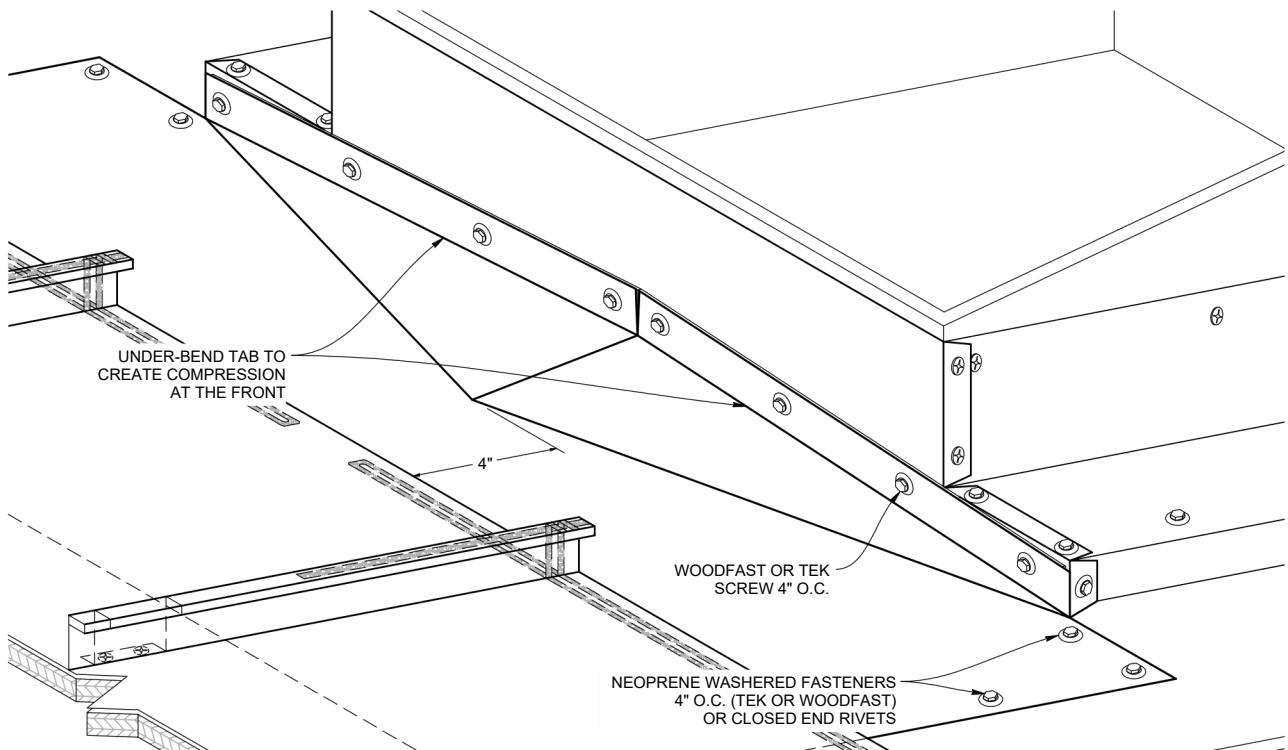

Note: All screws must be fastened into solid substrate.
Flashing must be lapped 4" with 3 rows of gunnable sealant.

CURB SIDEWALL DETAIL

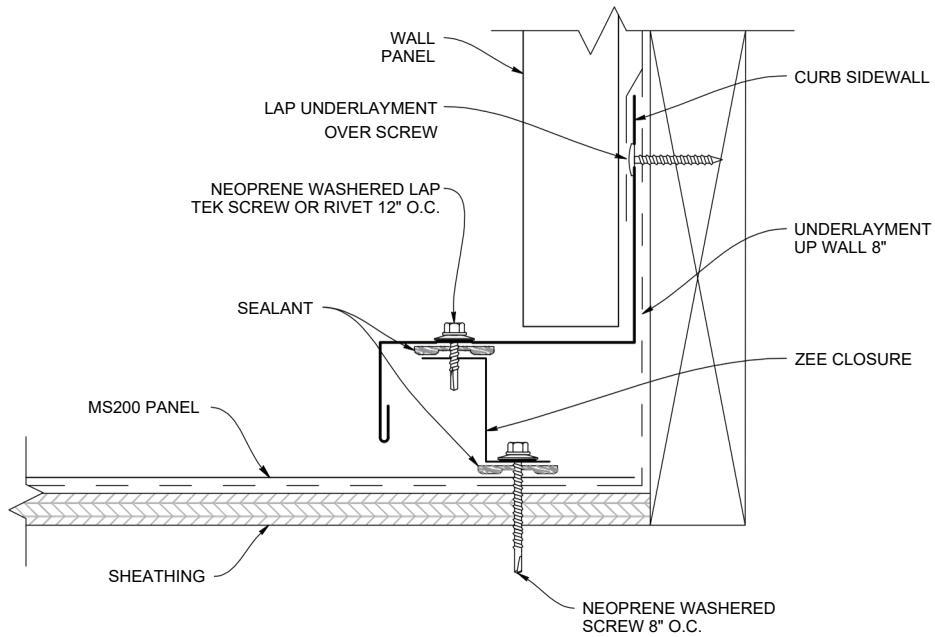

ZEE CLOSURE (MS200ZC)

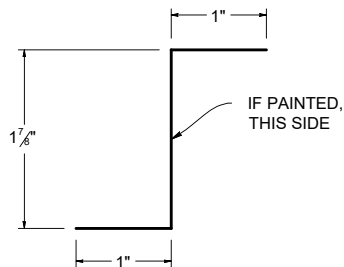

CURB SIDEWALL (MS200CSW)

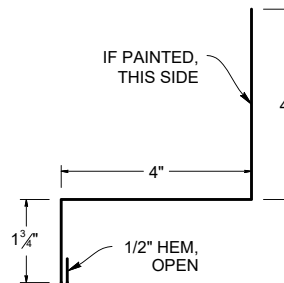

Note: All screws must be fastened into solid substrate.
Flashing must be lapped 4" with 3 rows of gunnable sealant.

CURB ENDWALL DETAIL

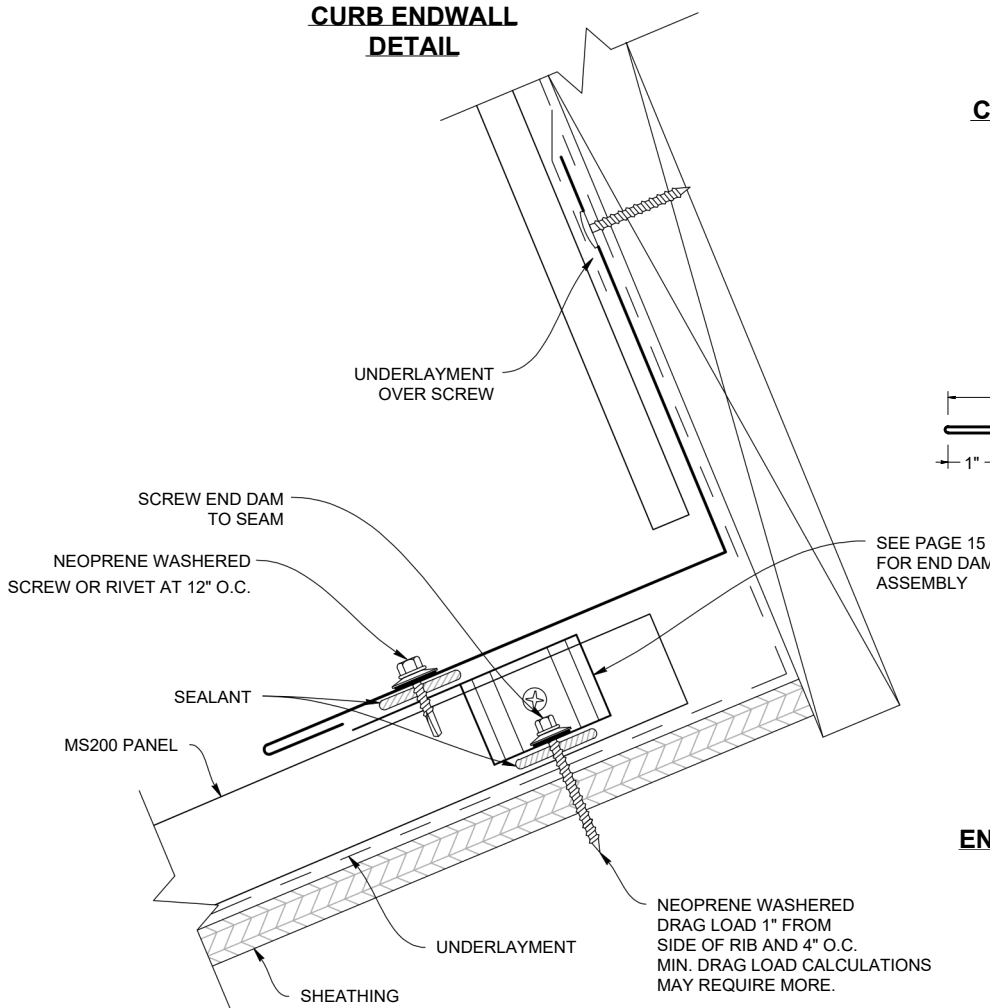

CURB ENDWALL (MS200CH)

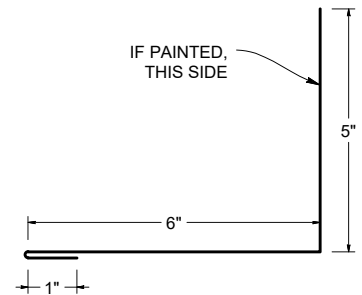

ENDWALL DETAIL

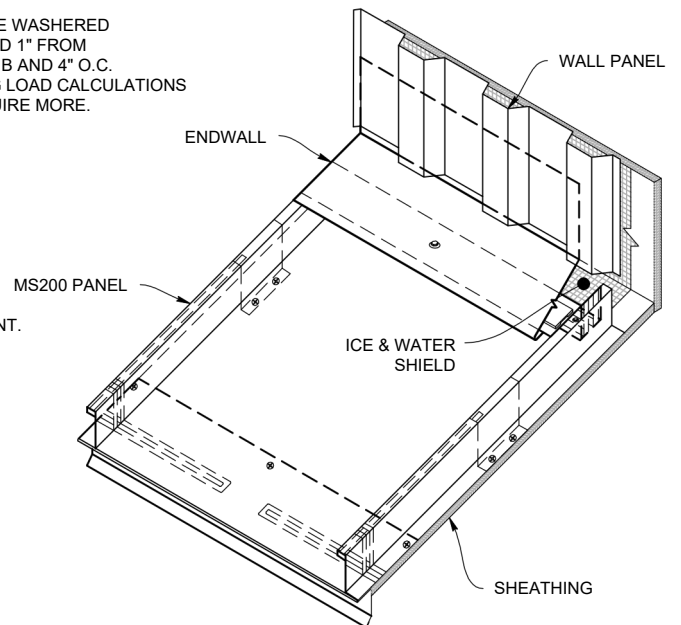

END DAM DETAIL

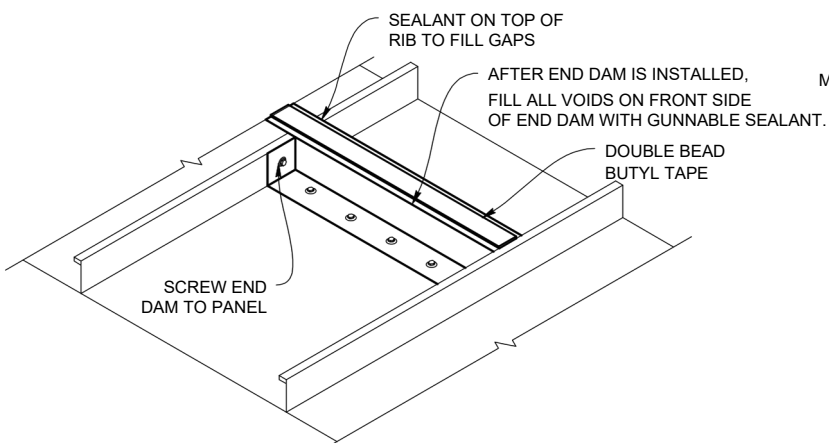

Note: All screws must be fastened into solid substrate.
Flashing must be lapped 4" with 3 rows of gunnable sealant.

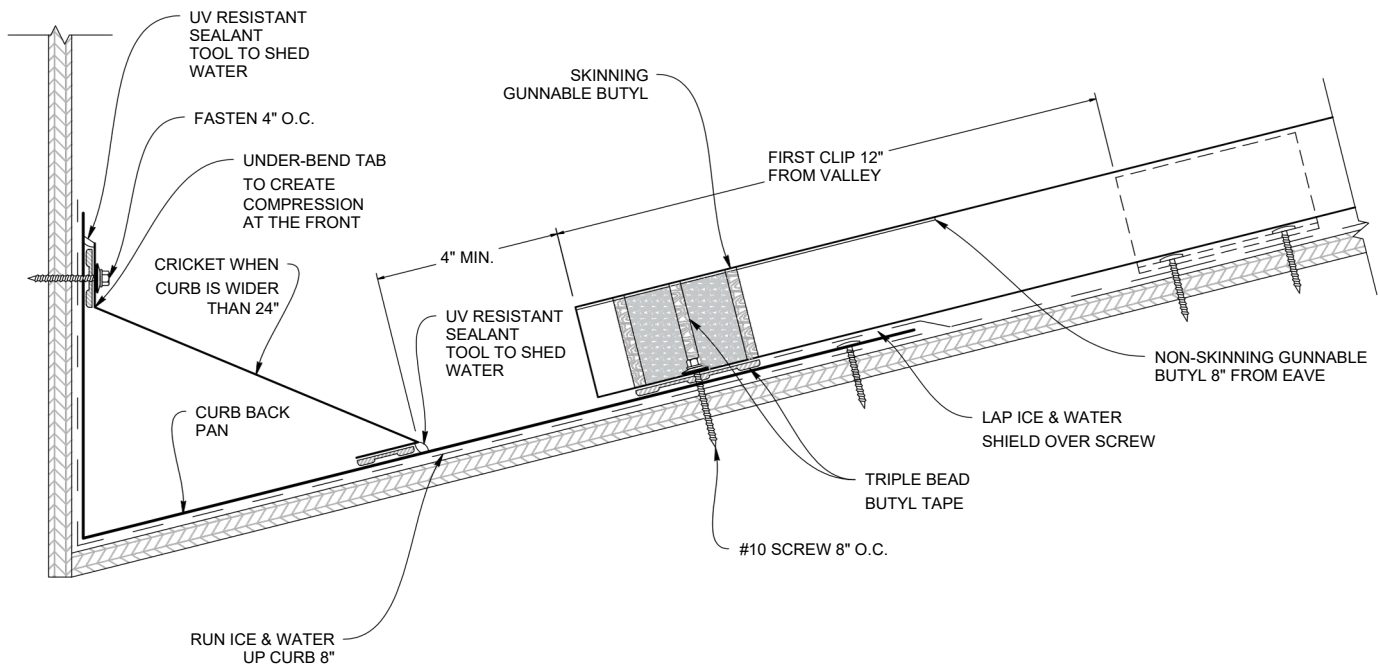
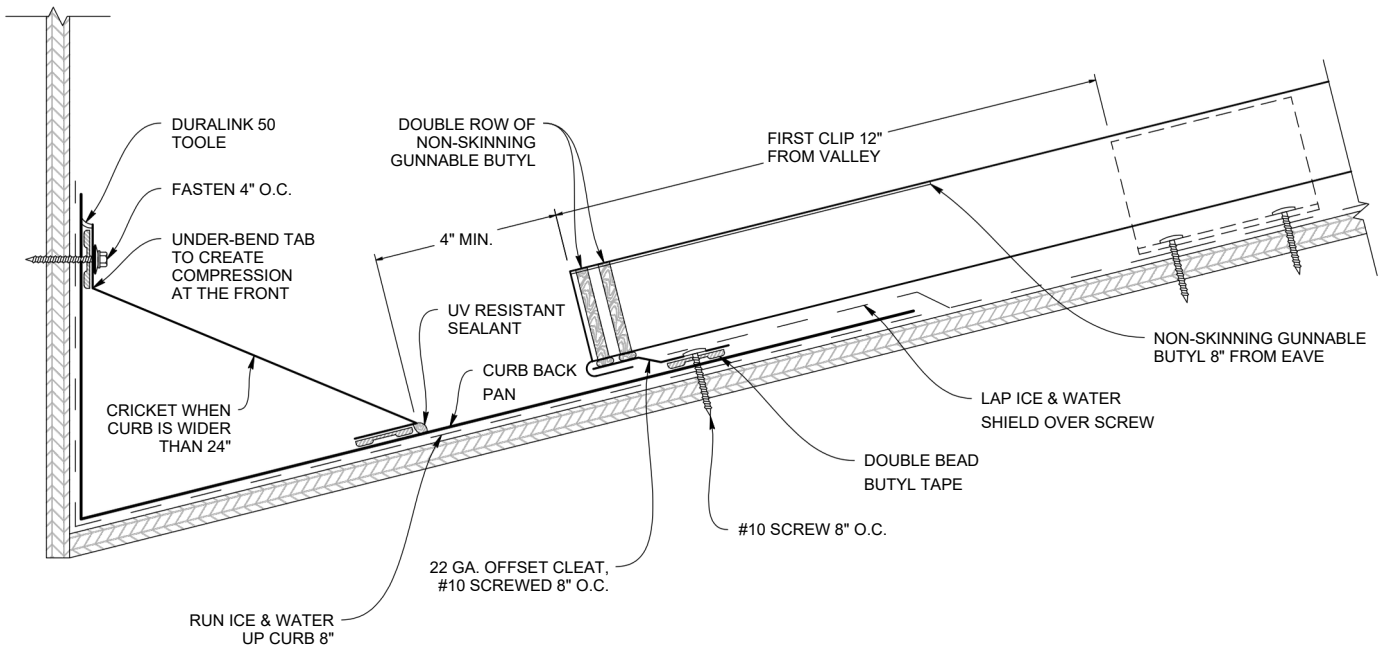

Note: All screws must be fastened into solid substrate.
Flashing must be lapped 4" with 3 rows of gunnable sealant.

EAVE TO GABLE TRANSITION

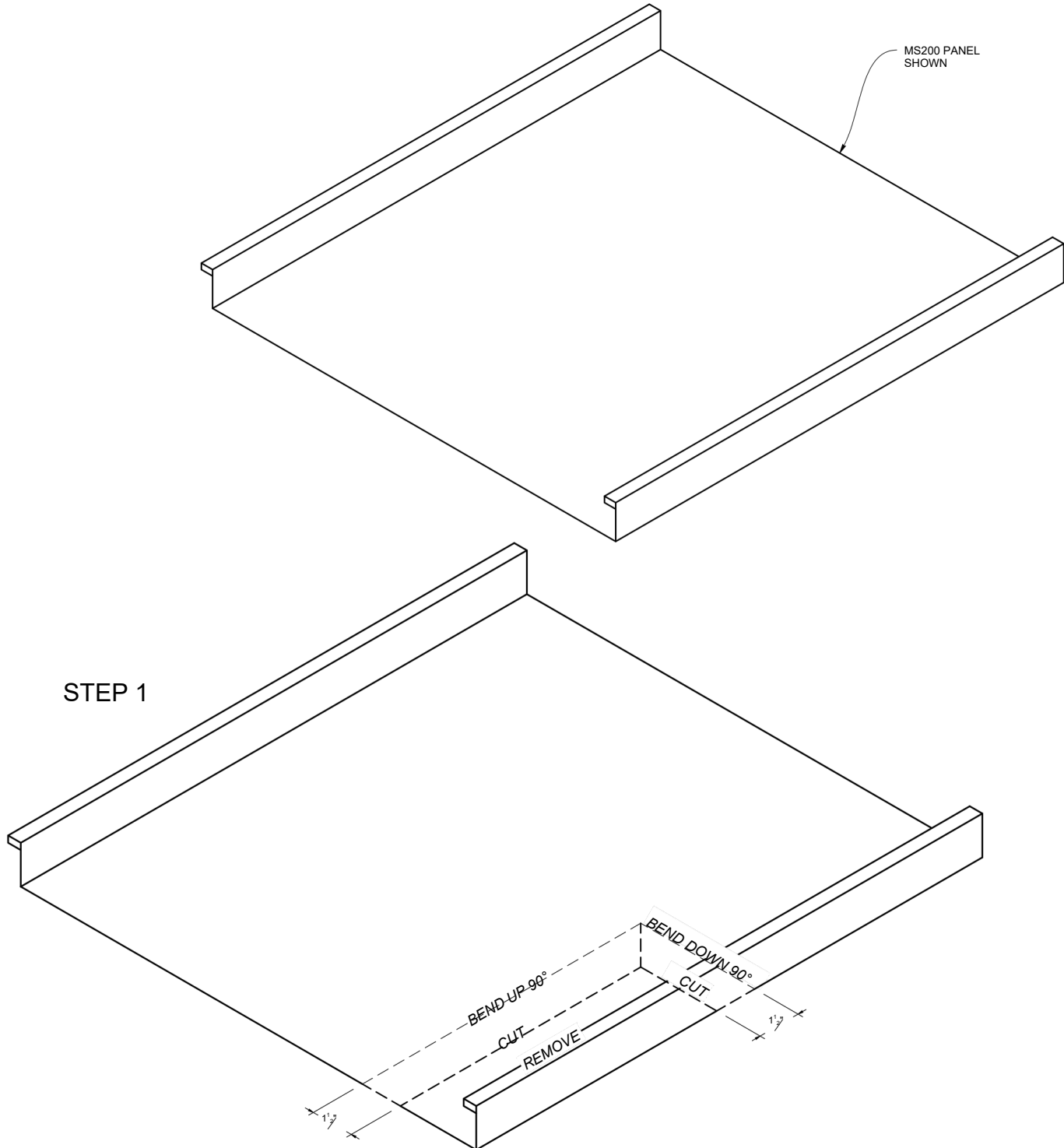

Note: All screws must be fastened into solid substrate.
Flashing must be lapped 4" with 3 rows of gunnable sealant.

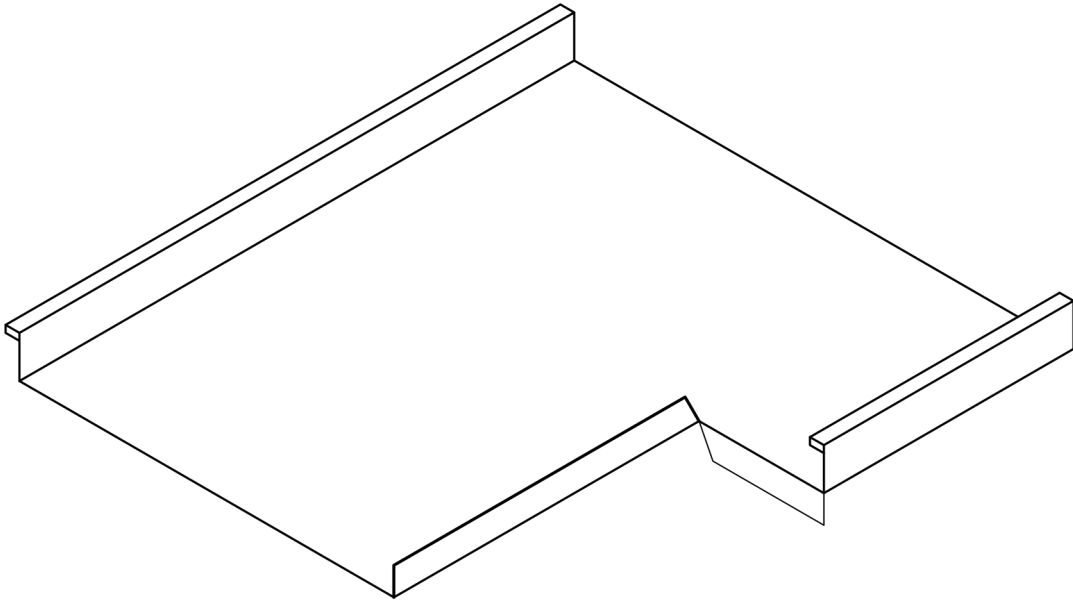

STEP 2

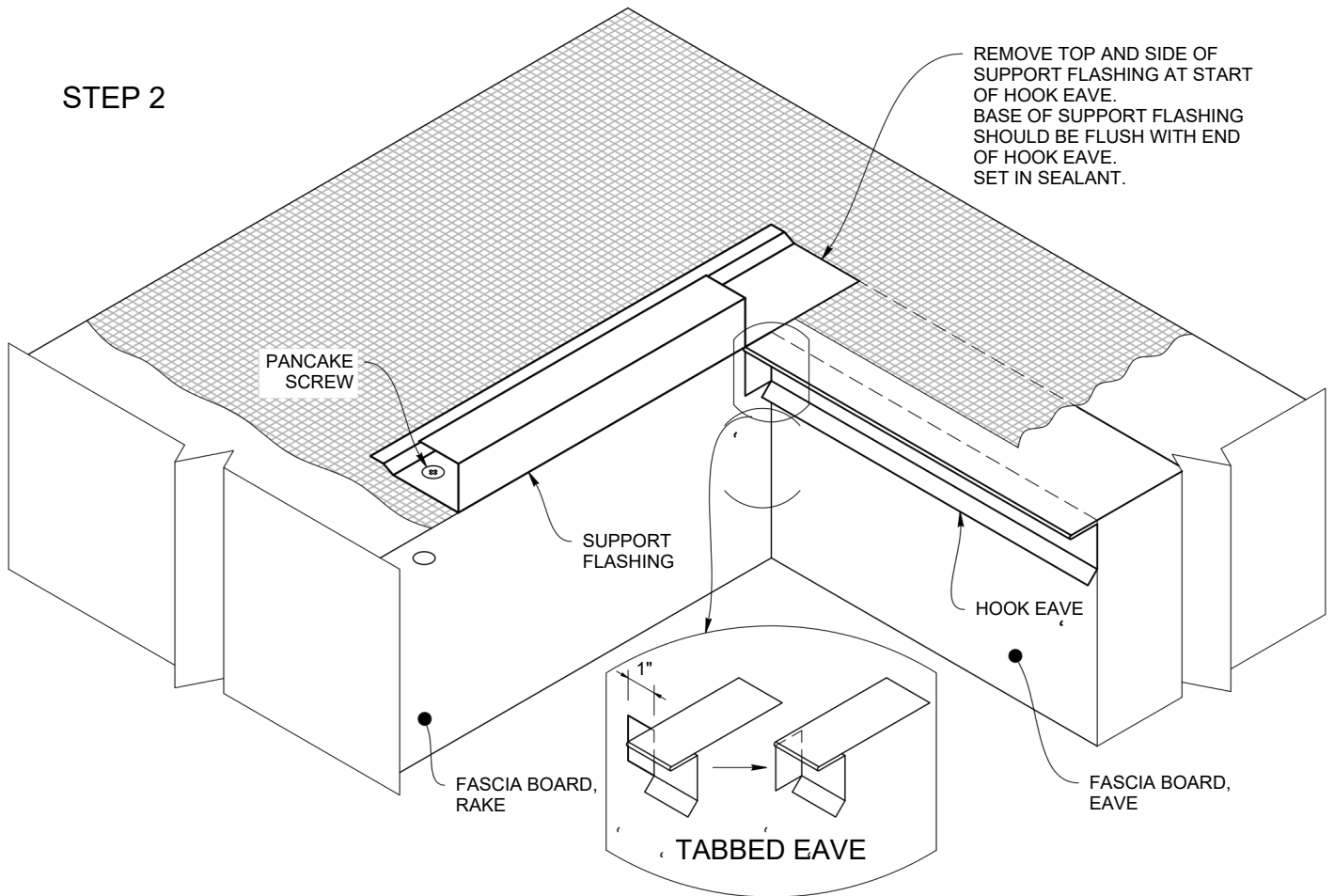

Note: All screws must be fastened into solid substrate.
Flashing must be lapped 4" with 3 rows of gunnable sealant.

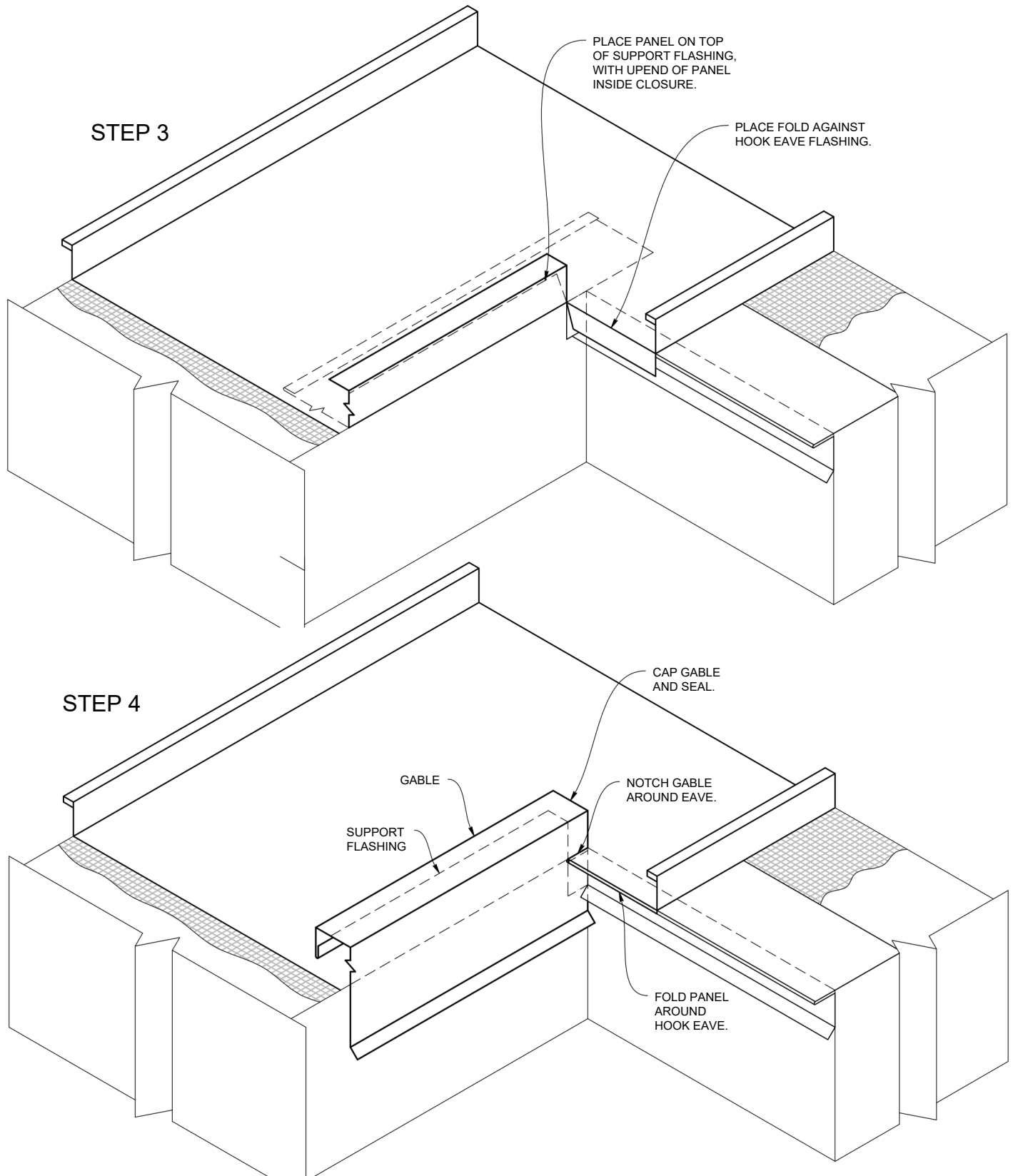

Note: All screws must be fastened into solid substrate.
Flashing must be lapped 4" with 3 rows of gunnable sealant.

Pipe Penetration - on Plate

FOR PIPES LOCATED 20' OR GREATER FROM PIN POINT

Allows panel and pipe flashing to move with temperature change.

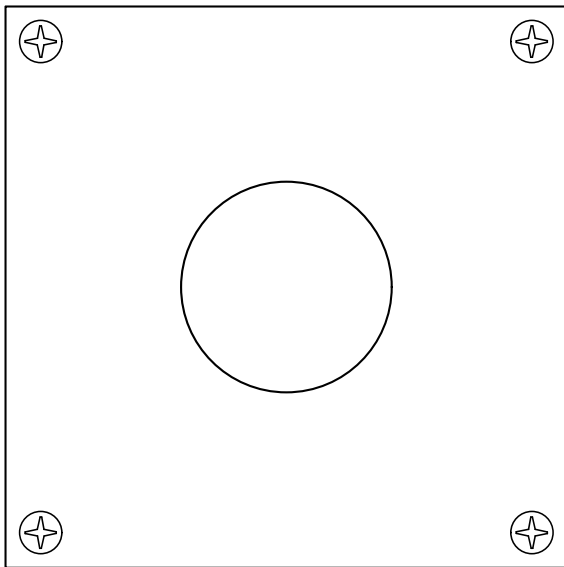
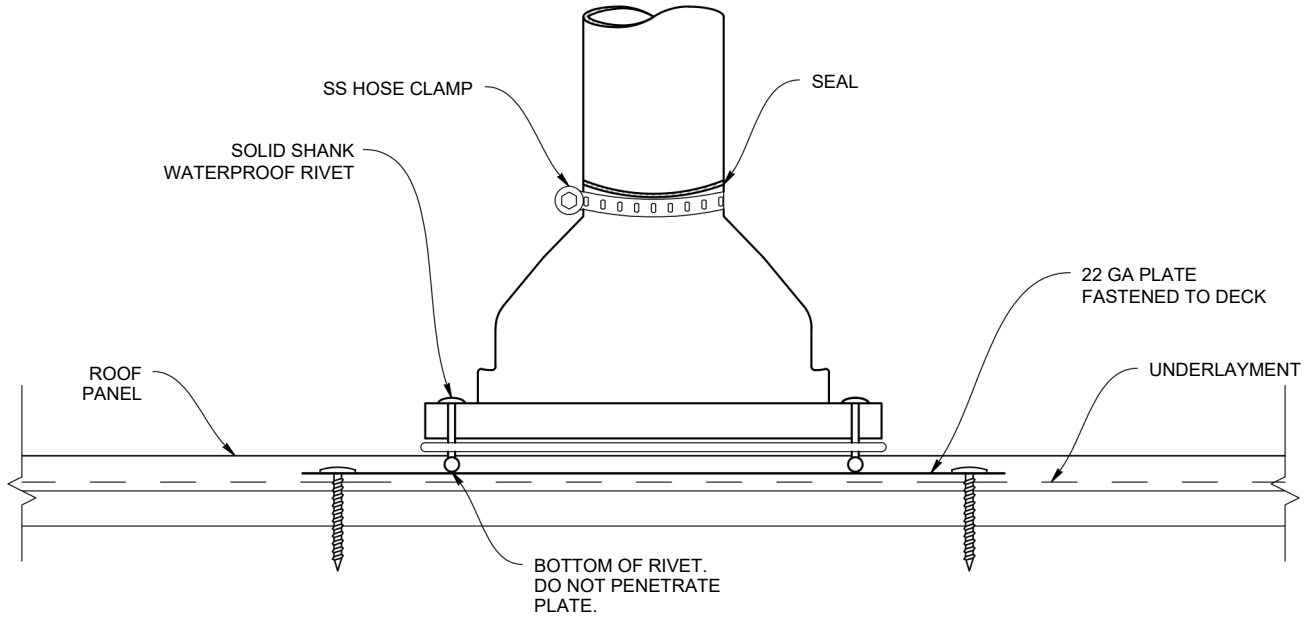

SINGLE 22 GAUGE PLATE

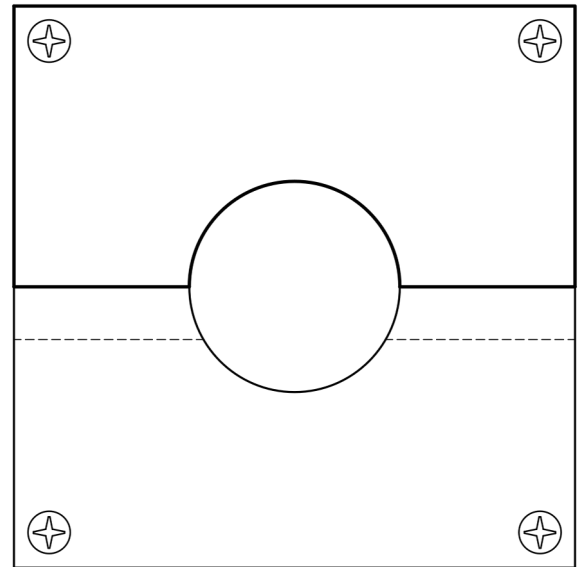

TWO OVERLAPPING 22 GAUGE PLATES

Note: All screws must be fastened into solid substrate.
Flashing must be lapped 4" with 3 rows of gunnable sealant.

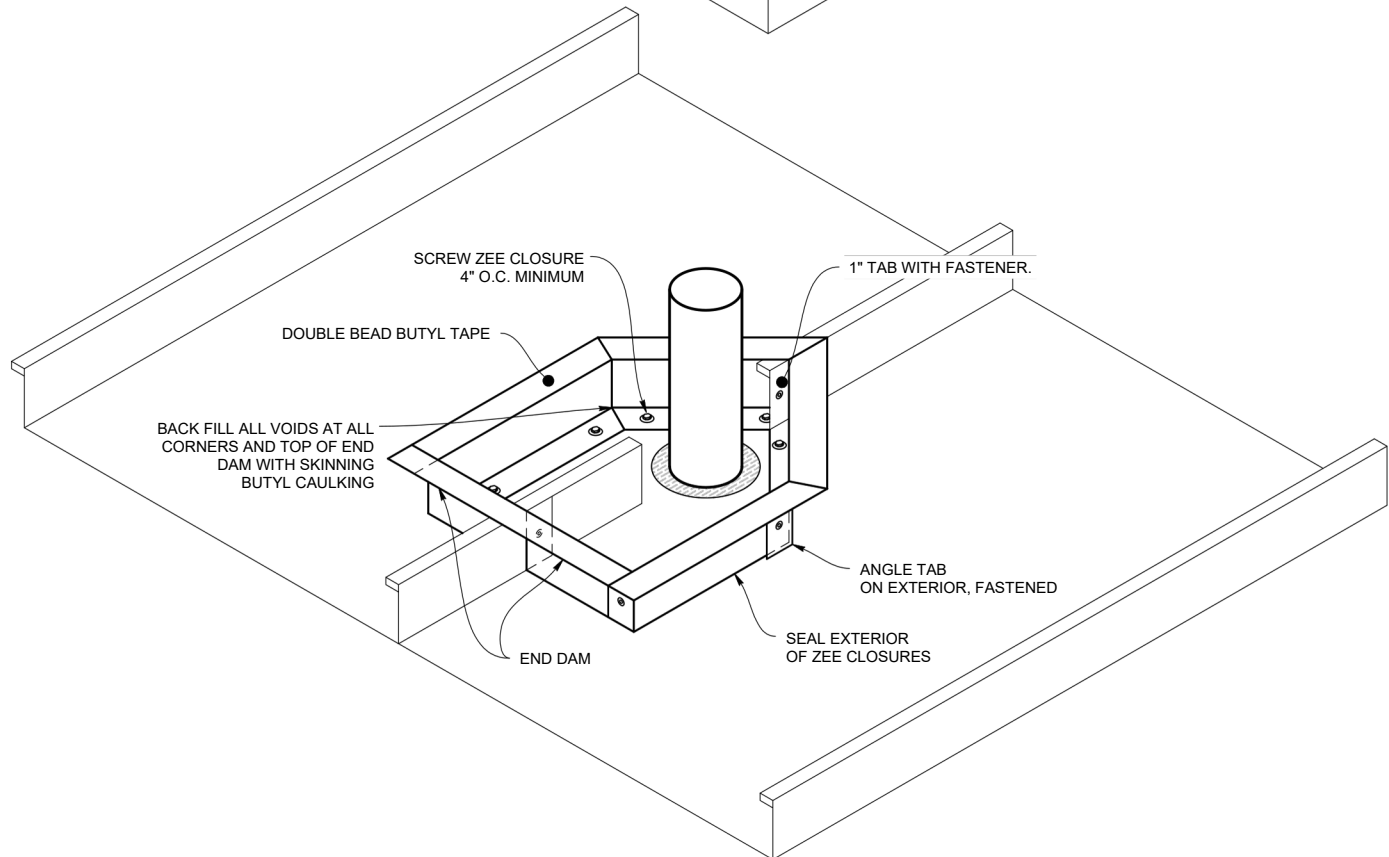
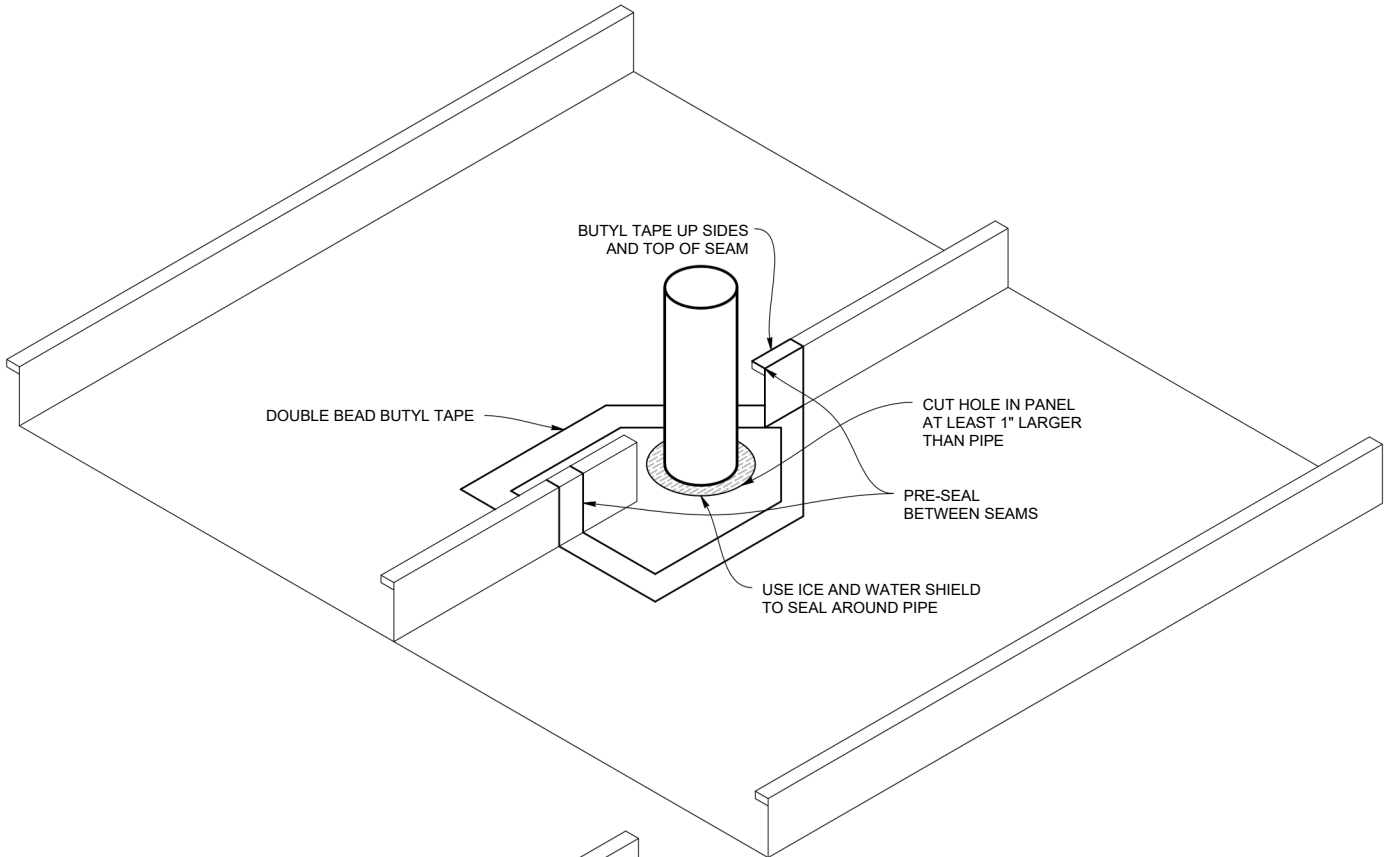

Note: All screws must be fastened into solid substrate.
Flashing must be lapped 4" with 3 rows of gunnable sealant.

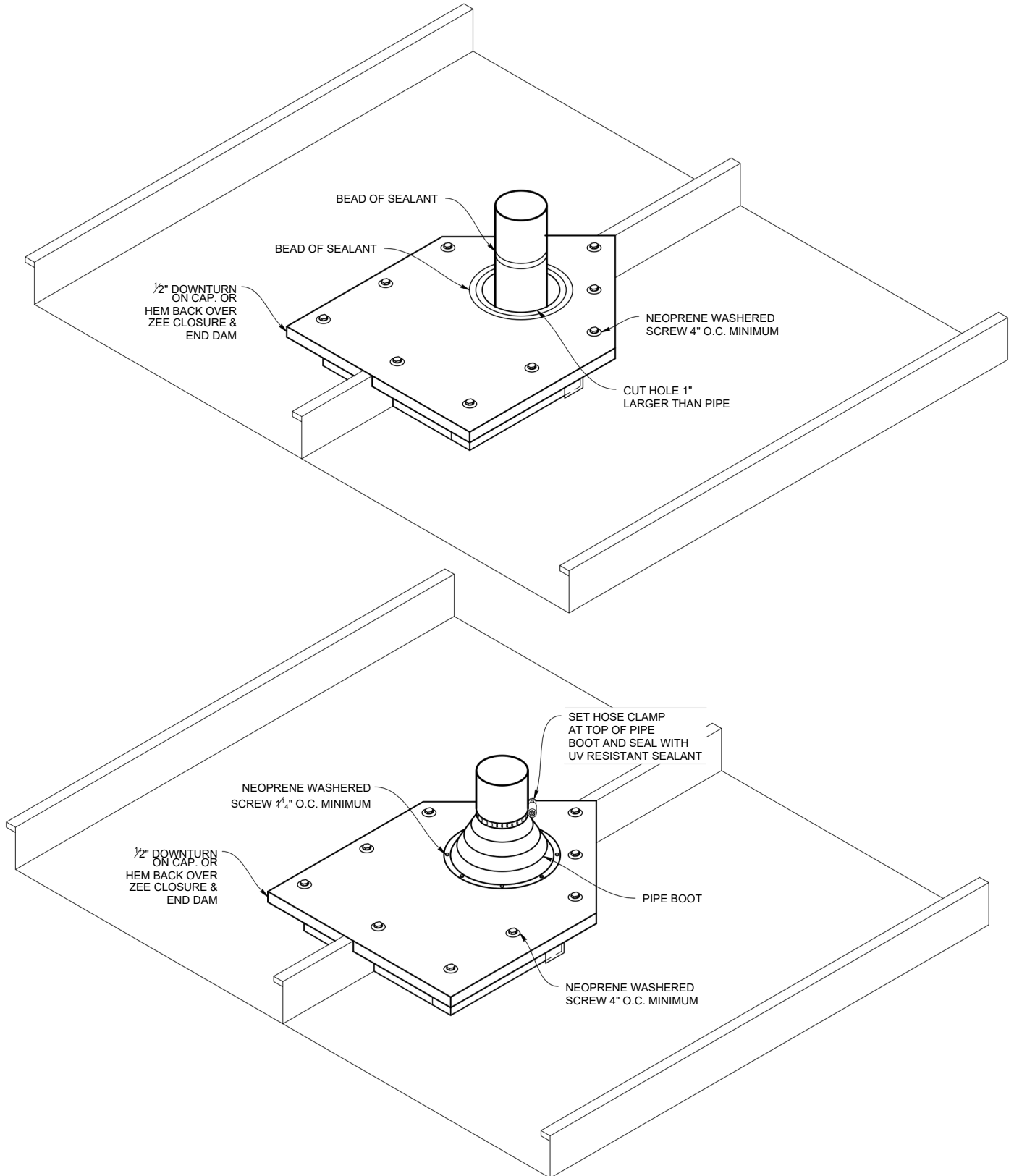

Note: All screws must be fastened into solid substrate.
Flashing must be lapped 4" with 3 rows of gunnable sealant.

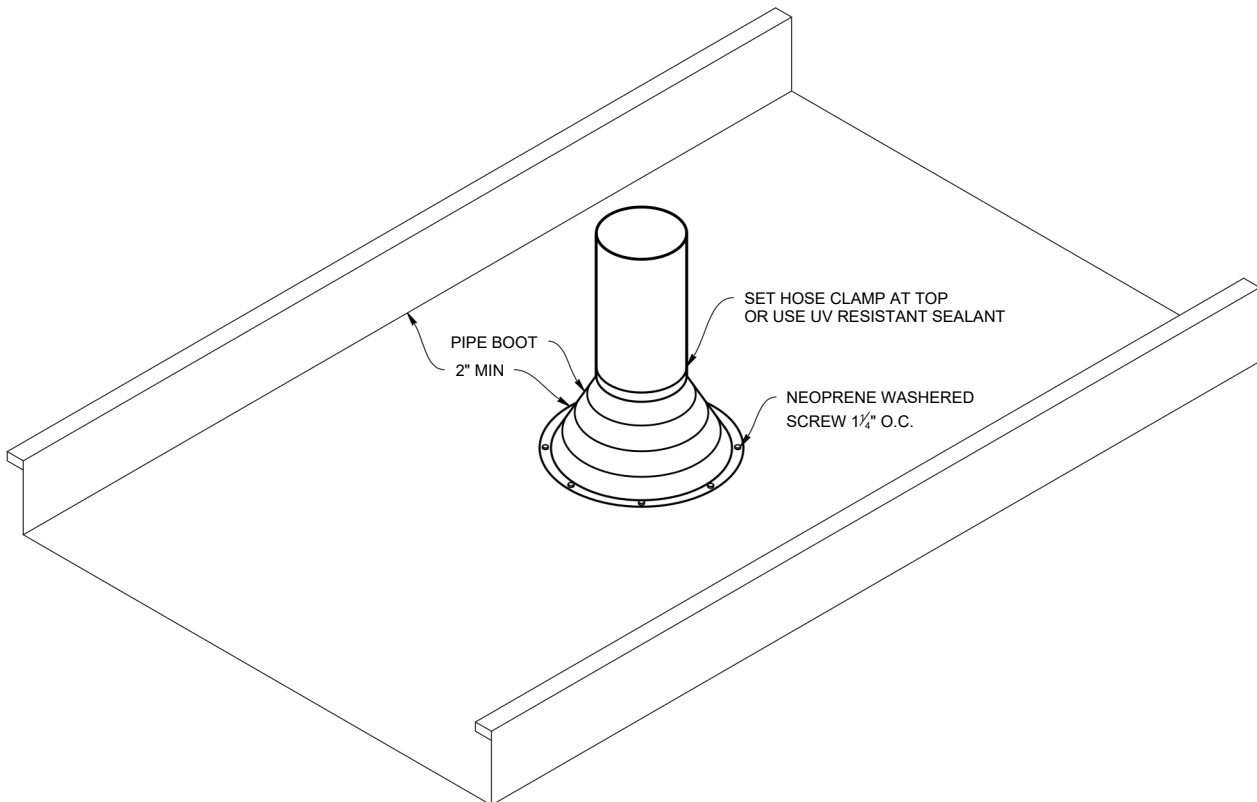
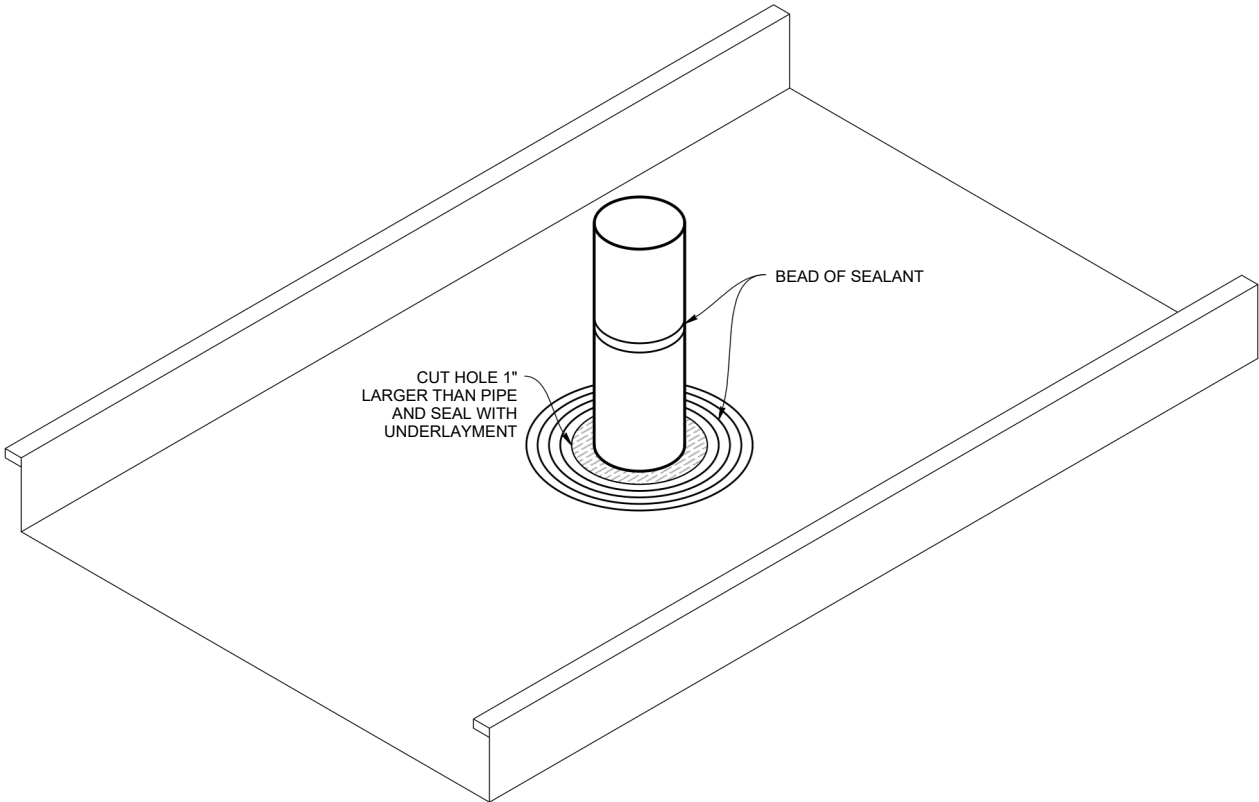

Note: All screws must be fastened into solid substrate.
Flashing must be lapped 4" with 3 rows of gunnable sealant.

<p>HOOK EAVE (MS200EH)</p> <p>IF PAINTED, THIS SIDE</p> <p>3 ³/₈"</p> <p>SPECIFY PITCH</p> <p>1 ¹/₂"</p> <p>135°</p> <p>5/8" KICK, 1/2" HEM, OPEN</p> <p>SCALE 1:2 S.O. 6" WEIGHT: 4.9 LBS.</p>	<p>HOOK EAVE (MS200EH)</p> <p>IF PAINTED, THIS SIDE</p> <p>4 ¹/₄"</p> <p>1 ¹/₈"</p> <p>SPECIFY PITCH</p> <p>1 ¹/₂"</p> <p>135°</p> <p>5/8" KICK, 1/2" HEM, OPEN</p> <p>SCALE 1:2 S.O. 8" WEIGHT: 6.5 LBS.</p>	<p>OFFSET CLEAT (MS200OC)</p> <p>NON-VISIBLE / SUB-FLASHINGS ARE NOT PROVIDED IN SPECIFIC COLORS UNLESS SPECIFIED</p> <p>1" 1 ¹/₂"</p> <p>1/2"</p> <p>2X 166°</p> <p>SCALE 1:2 S.O. 3" WEIGHT: 2.5 LBS.</p>
<p>GUTTER HANGER (AGH6)</p> <p>NON-VISIBLE / SUB-FLASHINGS ARE NOT PROVIDED IN SPECIFIC COLORS UNLESS SPECIFIED</p> <p>S.O. 0.5"</p> <p>1/2"</p> <p>1/2"</p> <p>6"</p> <p>1"</p> <p>WEIGHT: 6.5 LBS.</p> <p>SCALE 1:2</p>		
<p>BOX GUTTER (MS20065BG)</p> <p>3/4"</p> <p>1"</p> <p>1/2" HEM, OPEN</p> <p>1"</p> <p>3/4"</p> <p>2X 108°</p> <p>IF PAINTED, THIS SIDE</p> <p>4"</p> <p>6"</p> <p>5 ¹/₂"</p> <p>SCALE 1:3 S.O. 16" WEIGHT: 13.3 LBS.</p>	<p>BOX GABLE (MS200GB)</p> <p>1 ³/₄"</p> <p>1 ³/₄"</p> <p>1/2"</p> <p>IF PAINTED, THIS SIDE</p> <p>4 ³/₈"</p> <p>5/8" KICK, 1/2" HEM, OPEN</p> <p>135°</p> <p>SCALE 1:3 S.O. 9.5" WEIGHT: 7.6 LBS.</p>	<p>GABLE CLEAT (MS200GC)</p> <p>NON-VISIBLE / SUB-FLASHINGS ARE NOT PROVIDED IN SPECIFIC COLORS UNLESS SPECIFIED</p> <p>1"</p> <p>4 ¹/₄"</p> <p>135°</p> <p>1/2"</p> <p>SCALE 1:3 S.O. 5.75" WEIGHT: 4.7 LBS.</p>

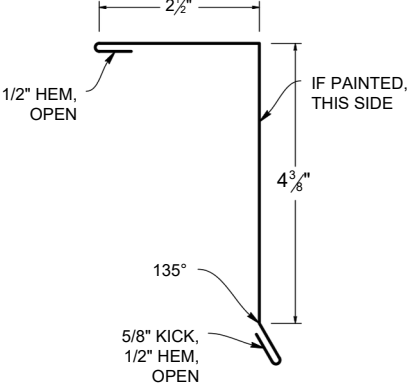
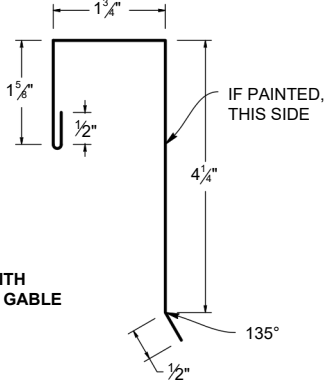
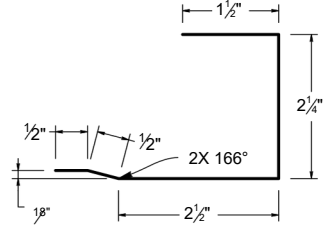
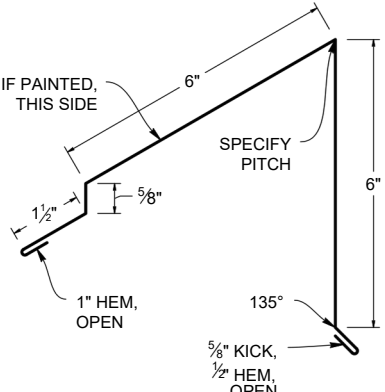
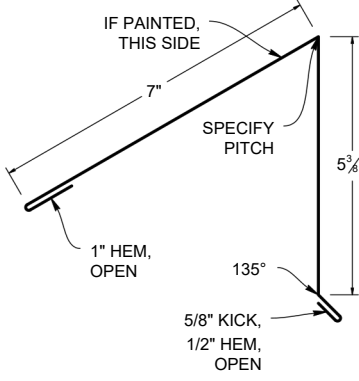
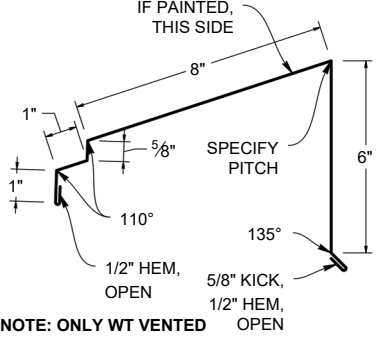
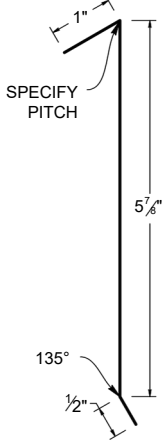
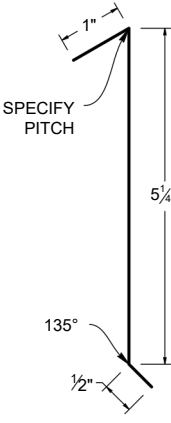
<p>ALTERNATE GABLE (MS200AG)</p>  <p>SCALE 1:3 S.O. 8.5" WEIGHT: 7 LBS.</p>	<p>ALT GABLE CLEAT (MS200AGC)</p>  <p>*FOR USE WITH ALTERNATE GABLE ONLY</p> <p>SCALE 1:3 S.O. 8.625" WEIGHT: 4.7 LBS.</p>	<p>SUPPORT FLASHING (MS200SF)</p> <p>NON-VISIBLE / SUB-FLASHING ARE NOT PROVIDE IN SPECIFIC COLORS UNLESS SPECIFIED</p>  <p>SCALE 1:3 S.O. 7.25" WEIGHT: 6 LBS.</p>
<p>VENTEDPEAK FLASHING (MS200RECV)</p>  <p>SCALE 1:4 S.O. 16.75" WEIGHT: 12.9 LBS.</p>	<p>PEAK FLASHING (MS200REC)</p>  <p>SCALE 1:4 S.O. 14.5" WEIGHT: 11.9 LBS.</p>	<p>WTVENTEDPEAK FLASHING (MS200WTRECV)</p>  <p>**NOTE: ONLY WT VENTED PEAK COMPATIBLE WITH PERFORATED VENT DRIP (PVD)**</p> <p>SCALE 1:6 S.O. 18.25" WEIGHT: 12.9 LBS.</p>
<p>VENTEDPEAK CLEAT (MS200VRECC)</p> <p>FOR USE WITH MS200RECV AND MS200WTRECV ONLY</p> <p>NON-VISIBLE / SUB-FLASHINGS ARE NOT PROVIDED IN SPECIFIC COLORS UNLESS SPECIFIED</p>  <p>SCALE 1:3 S.O. 7.375" WEIGHT: 2.5 LBS.</p>	<p>PEAK CLEAT (MS200RECC)</p> <p>FOR USE WITH MS200REC ONLY</p> <p>NON-VISIBLE / SUB-FLASHINGS ARE NOT PROVIDE IN SPECIFIC COLORS UNLESS SPECIFIED</p>  <p>SCALE 1:3 S.O. 6.75" WEIGHT: 6 LBS.</p>	

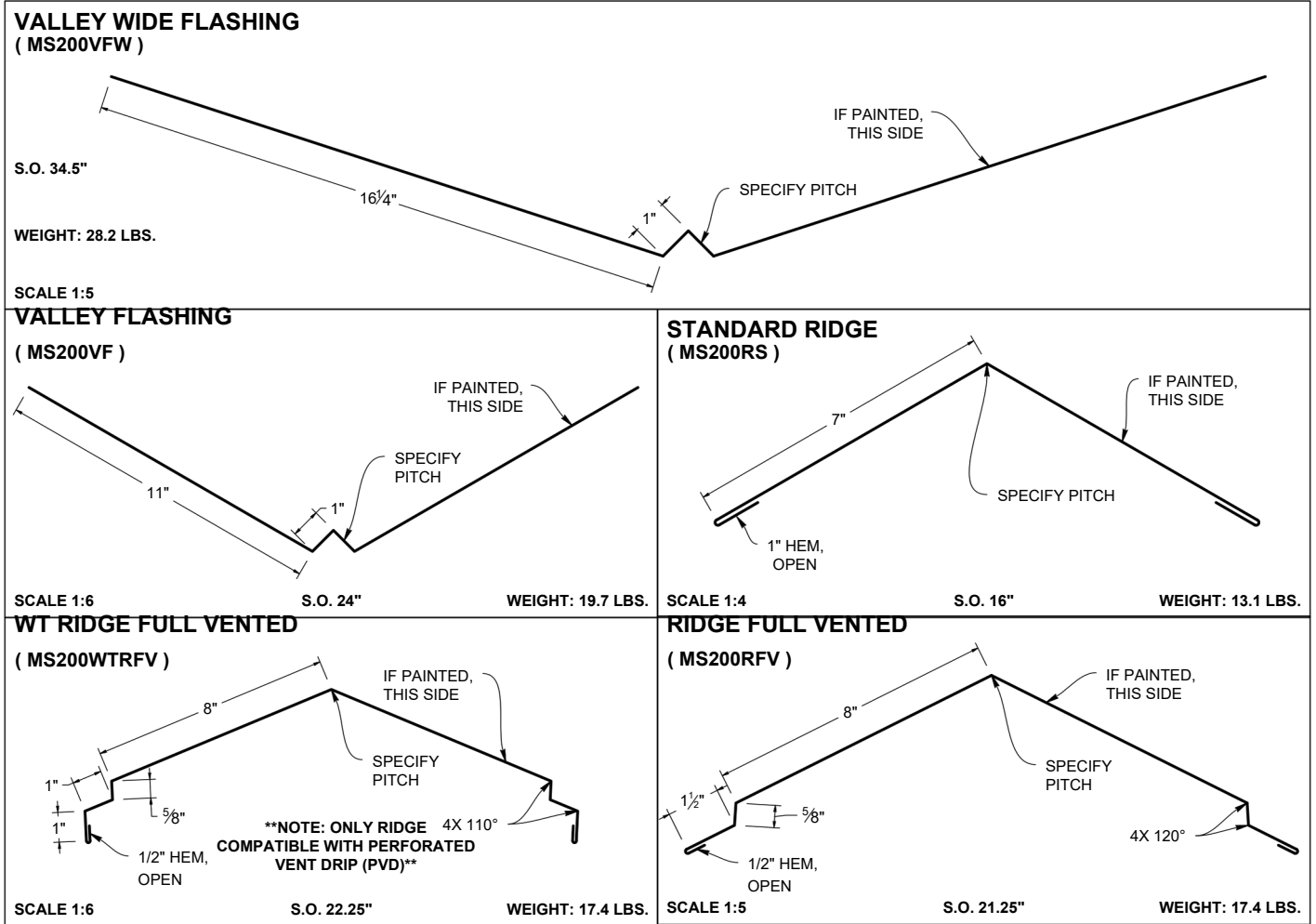

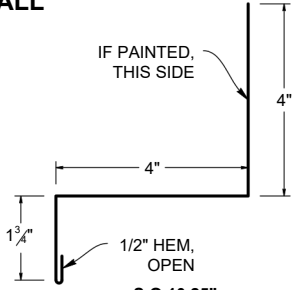
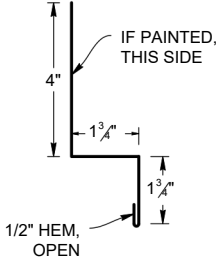
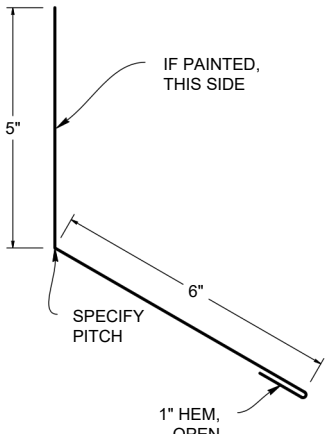
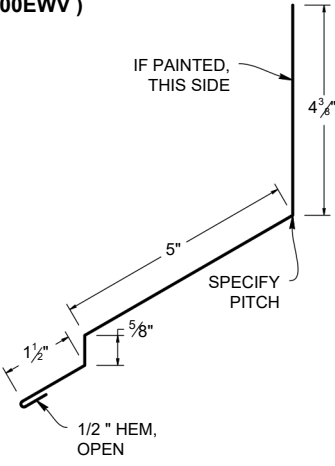
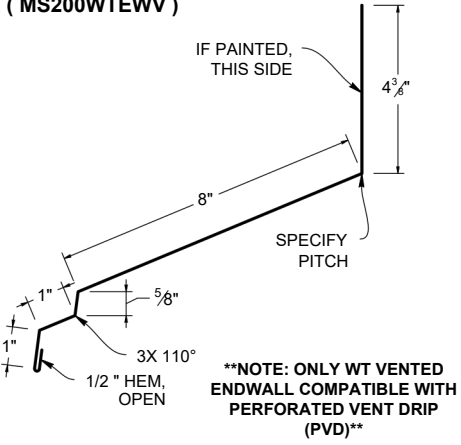
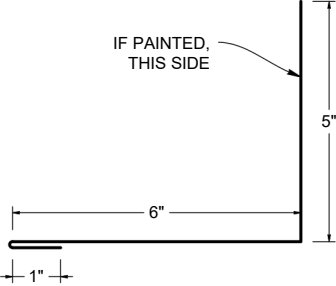
<p>CURB SIDEWALL (MS200CSW)</p>  <p>IF PAINTED, THIS SIDE</p> <p>4"</p> <p>4"</p> <p>1 3/4"</p> <p>1/2" HEM, OPEN</p> <p>SCALE 1:4</p> <p>S.O. 10.25"</p> <p>WEIGHT: 8.2 LBS.</p>	<p>SIDEWALL (MS200SW)</p>  <p>IF PAINTED, THIS SIDE</p> <p>4"</p> <p>1 3/4"</p> <p>1 3/4"</p> <p>1/2" HEM, OPEN</p> <p>SCALE 1:5</p> <p>S.O. 8"</p> <p>WEIGHT: 6.6 LBS.</p>	
<p>ENDWALL (MS200EW)</p>  <p>IF PAINTED, THIS SIDE</p> <p>5"</p> <p>6"</p> <p>SPECIFY PITCH</p> <p>1" HEM, OPEN</p> <p>SCALE 1:4</p> <p>S.O. 12"</p> <p>WEIGHT: 9.8 LBS.</p>	<p>VENTED ENDWALL (MS200EWV)</p>  <p>IF PAINTED, THIS SIDE</p> <p>4 3/8"</p> <p>5"</p> <p>SPECIFY PITCH</p> <p>1 1/2"</p> <p>5/8"</p> <p>1/2" HEM, OPEN</p> <p>SCALE 1:4</p> <p>S.O. 12"</p> <p>WEIGHT: 12.6 LBS.</p>	<p>WT VENTED ENDWALL (MS200WTEWV)</p>  <p>IF PAINTED, THIS SIDE</p> <p>4 3/8"</p> <p>8"</p> <p>SPECIFY PITCH</p> <p>1"</p> <p>5/8"</p> <p>3X 110°</p> <p>1/2" HEM, OPEN</p> <p>**NOTE: ONLY WT VENTED ENDWALL COMPATIBLE WITH PERFORATED VENT DRIP (PVD)**</p> <p>SCALE 1:5</p> <p>S.O. 15.5"</p> <p>WEIGHT: 10.7 LBS.</p>
<p>CURB ENDWALL (MS200CH)</p>  <p>IF PAINTED, THIS SIDE</p> <p>5"</p> <p>6"</p> <p>1"</p> <p>SCALE 1:4</p> <p>S.O. 12"</p> <p>WEIGHT: 9.8 LBS.</p>		

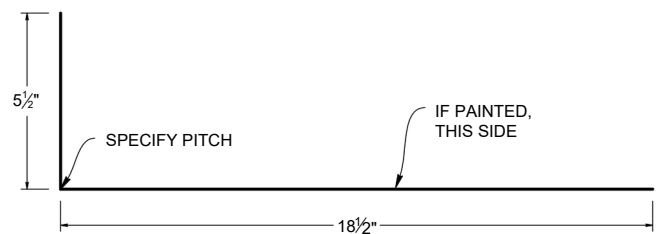
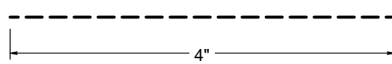
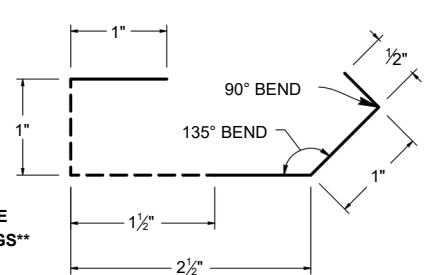
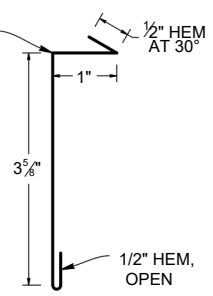
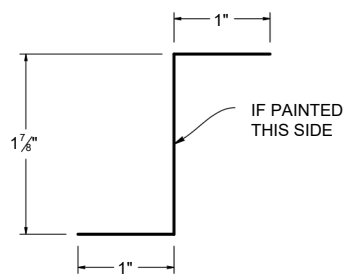
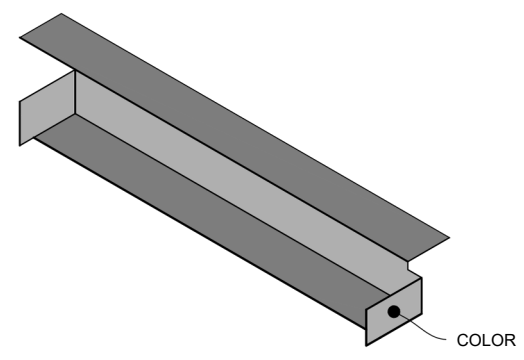
<p>(MS200PAN)</p>  <p>SCALE 1:6 S.O. 24" WEIGHT: 19.53 LBS.</p>	<p>4" PERFORATED STRIP (MS200PS)</p> <p>NON-VISIBLE / SUB-FLASHING ARE NOT PROVIDE IN SPECIFIC COLORS UNLESS SPECIFIED</p>  <p>SCALE 1:2 S.O. 4" WEIGHT: 3.3 LBS.</p>
<p>PERFORATED VENT DRIP: E2886 EMBER RESISTANT (MS200PVD)</p> <p>NON-VISIBLE / SUB-FLASHINGS ARE NOT PROVIDED IN SPECIFIC COLORS UNLESS SPECIFIED</p> <p>**NOTE: COMPATIBLE WITH ALL WT FLASHINGS**</p>  <p>SCALE 1:2 S.O. 6" WEIGHT: 4.88 LBS.</p>	<p>REGLET (MS200RF)</p> <p>IF PAINTED, THIS SIDE</p>  <p>SCALE 1:3 S.O. 5.625" WEIGHT: 4.6 LBS.</p>
<p>ZEE CLOSURE (MS200ZC)</p> <p>* HEIGHT ALLOWS FOR 1/8" DOUBLE BEAD BUTYL TAPE. IF USING CAULKING PLEASE INQUIRE OF NMP REP</p>  <p>SCALE 1:2 S.O. 3.875" WEIGHT: 3 LBS.</p>	
<p>END DAM</p>  <p>S.O. VARIES</p> <p>WEIGHT: VARIES</p>	