

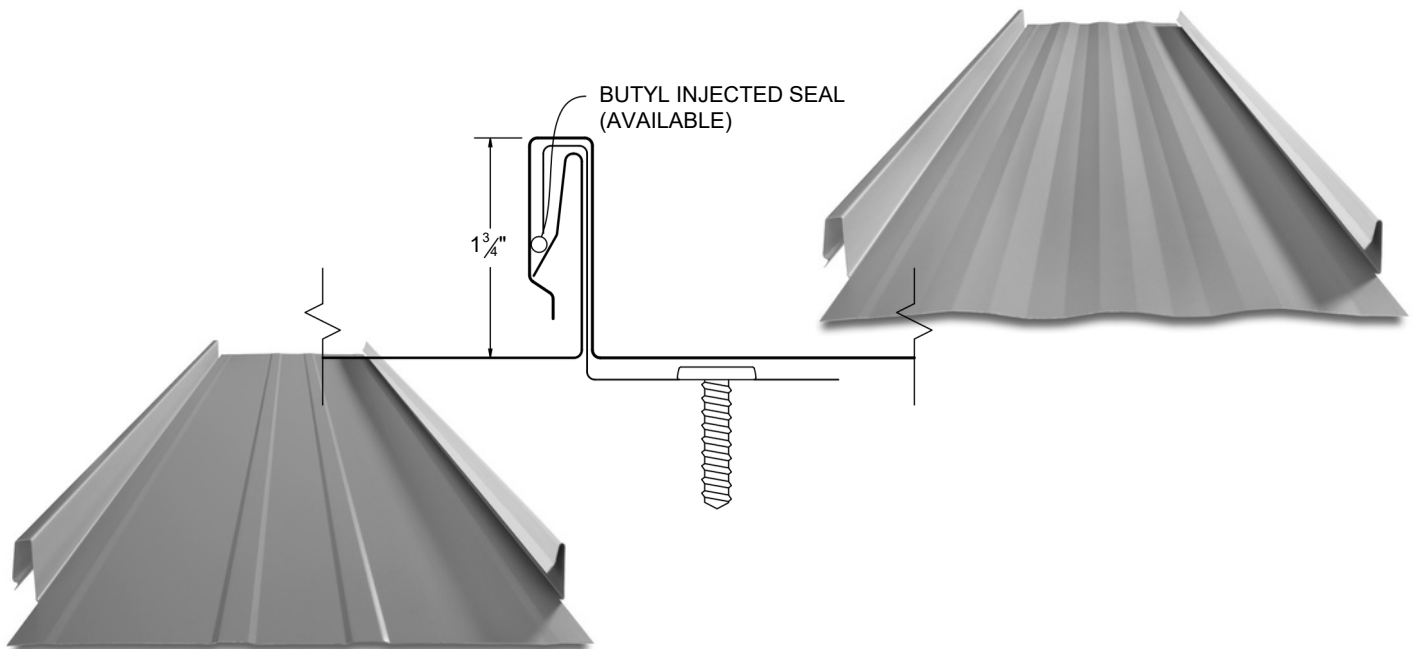

Versa-Span™ Installation Guide - WeatherTightWarranty Details

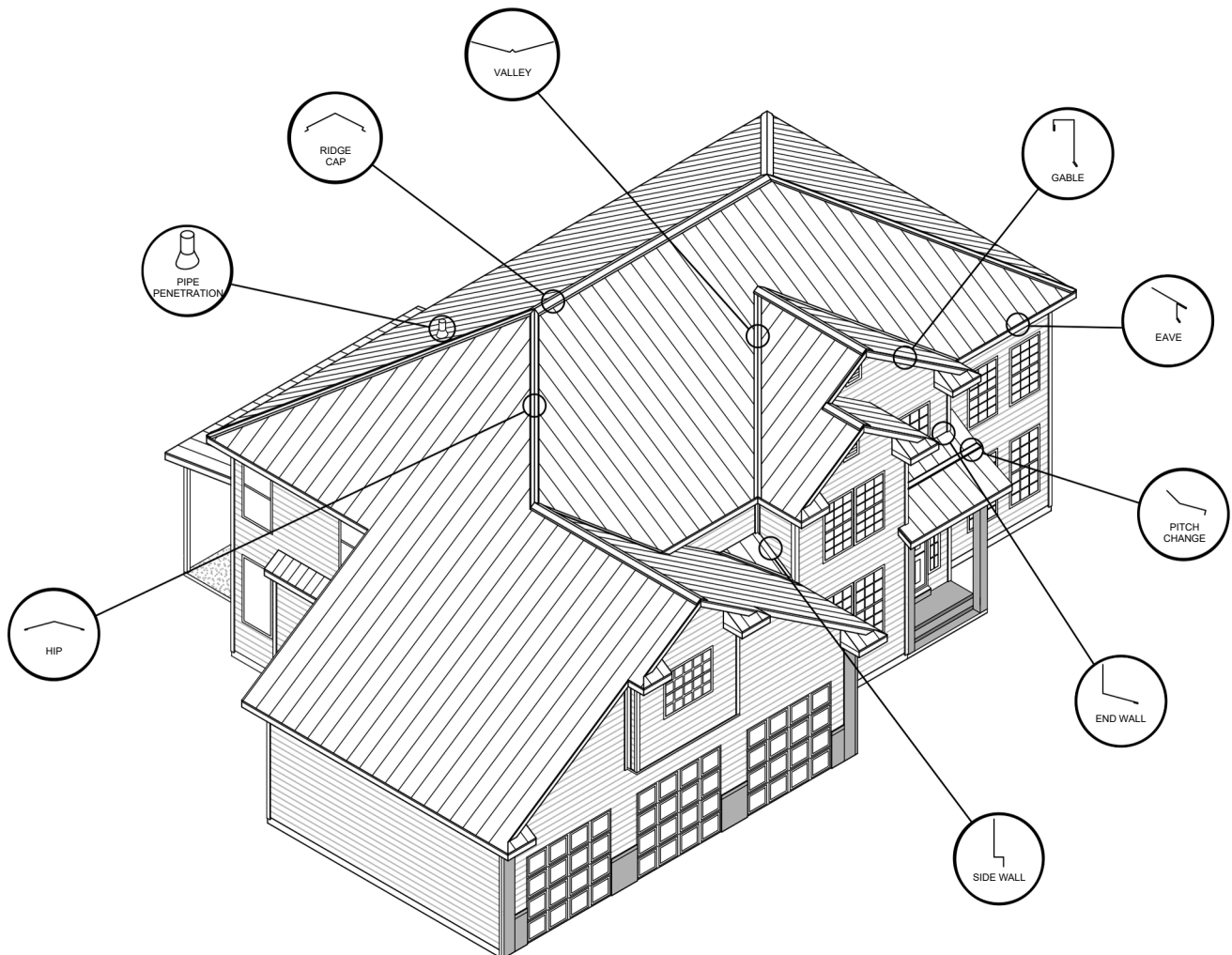

● Panel Specifications.....	2-3	● Peak Flashing Detail (R.E.C.).....	20
● Nor-Cal Delivery Fleet.....	4	● Vented Peak Flashing (R.E.C.).....	21
● Delivery & Will Call/Loading.....	5	● Pitch Change Detail.....	22
● Notes to Designer/Installer.....	6-7	● Endwall Detail.....	23
● Handling & Storage.....	8	● Vented Endwall Detail.....	24
● Standard Eave Detail.....	9	● Saw Cut Endwall Detail.....	25
● Hook Eave Detail.....	10	● Curb/Pan Cricket Detail.....	26-28
● Hook Eave with Gutter.....	11	● Curb Sidewall Detail.....	29
● Standard Ridge Detail.....	12	● Curb Endwall Detail.....	30
● Vented Ridge Detail.....	13	● Curb/Pan Cricket Detail.....	31
● End Dam Attachment Detail.....	14	● Eave to Gable Transition.....	32-34
● Valley - High Pitch Detail.....	15	● Pipe Penetration - On Plate.....	35
● Valley - Low Pitch Detail.....	16	● Pipe Penetration - On Rib.....	36-37
● Standard Gable Detail.....	17	● Pipe Penetration - On Pan.....	38
● Alternate Gable Detail.....	18	● Flashing Selection.....	39-42
● Sidewall Detail.....	19	●	





ICC
EVALUATION
SERVICE®

ICC-ES EVALUATION REPORT #5046 with CBC-CRC Supplement

12", 14", 16" & 18" coverage options

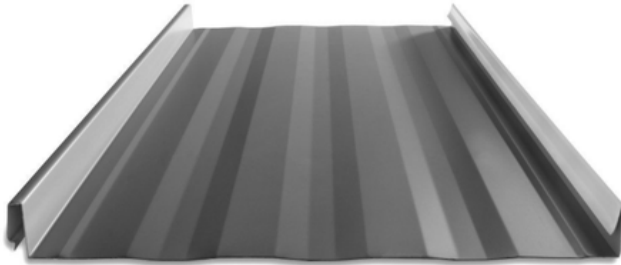

STRIATIONS

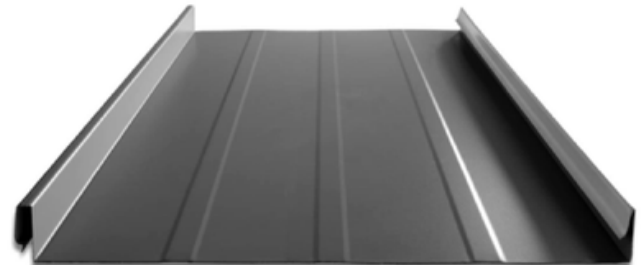

FLAT ACCENT RIBS

2 Accent ribs for 12" & 14" panels
3 Accent ribs for 16" & 18" panels

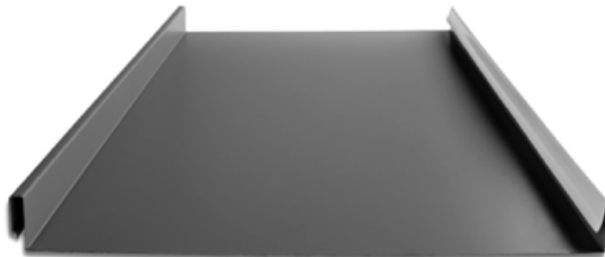

FLAT PAN

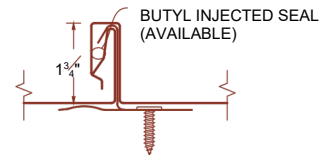

*wide batten
options



KEY FEATURES

- 12", 14", 16" & 18" Coverage Options
- 24 and 22 Tru-Gauge™ and .032" and .040 Aluminum
- Floating clip system: allows for expansion and contraction of panels in longer lengths
- 1-3/4" Vertical Rib, factory notching available
- 2:12 minimum pitch recommended
(For lower pitches, please inquire)
- Standard panel lengths 1' to 60'
(For longer length panels, please inquire)
- On-site roll forming available for longer panels
- Factory injected Butyl sealant available
- Clip Relief is not standard, available upon request
- Wide Batten incorporates nicely over Versa-Span™ standing seam panel (*separate clip required*)
- Weathertightness warranty available
(Contact NMP representative for details)
- Manufactured in Sacramento CA

TESTING

-  ICC-ESR #5046 with CBC-CRC Supplement
-  Code compliance UL Evaluation Report
UL ER #25913-01
- UL Construction No. 254, 255, 261, 303, 342, 343, 414, 436, 445, 447, 448, 486, 508, 508A, 543, 544
- UL 580 Class 90 - Wind Uplift
- UL 790 Class A (ASTM E108) - Fire rated
- UL 2218 Class 4 - Impact (hail) rated
- ASTM E1680 - Air infiltration (roof)
- ASTM E1646 - Water infiltration (roof)
- ASTM E1592 - Structural uniform static air pressure
- ASTM E1514 Standard for Structural Standing steel roof panels systems.
- ASTM E331 - Water infiltration (wall)
- ASTM E283 - Air infiltration (wall)
- ASTM A653/A924 - G90 Galvanized
- ASTM A792 - Zincalume/Galvalume AZ-50/55
- ASTM B209 - Aluminum Substrate
- ASTM E2886 - Ember Resistant ridge/endwall/peak flashings available

MATERIAL SPECIFICATIONS

- 24 Tru-Gauge™ Kynar500® Painted Steel
- ▲ 22 Tru-Gauge™ Kynar 500® Painted Steel
- ◆ .032" Kynar 500® Painted Aluminum
- 24 Tru-Gauge™ G-90 Galvanized or AZ-50
- 24 and 22 Tru-Gauge™ bare Zinalume® Plus AZ-55 (No finish warranty – 25 yr. perforation warranty)
- G-90 Galvanized or AZ-50
- .040" Kynar 500® Painted Aluminum (please inquire)
- 24 Tru-Gauge™ Bonderized
- 22 gauge Rusteel Plus™ (A606)
- Custom 20 & 18 Tru-Gauge™ and .050" and .063" Aluminum (please inquire)
- 16 OZ & 20 OZ Real Copper (please inquire)
- Kynar 500® and substrate testing data available (See website)
- PVDF is a fluoropolymer that is manufactured under the trademarked names Kynar 500® and Duranar® (PPG). Paint finishes containing a minimum 70% PVDF resin meet the high-performance weathering criteria established by the American Architectural Manufacturing Association and are allowed to carry the Kynar500® trademarked name. Zinalume & Zinalume® Plus are registered trademarks of Bluescope Ltd. Galvalume® is a registered trademark of BIEC International, Inc. Vintage® is a registered trademark of Steelscape, Inc. Kynar® and Kynar 500® is a registered trademarks of Arkema, Inc.

FINISHES

- 21 Standard Colors, 5 Metallic Colors and 4 Specialized Colors
- Kynar 500® Paint System - the ultimate in exterior durability and color retention
- "Cool" color pigments are specially designed to reflect infrared light, reducing heat gain to dwelling, and conform with ENERGY STAR® criteria
- Superior quality, two coat, 70% resin finish, applied at a 1 mil. thickness
- 40 year residential paint warranty
- 20 and 30 year commercial paint warranty: Contact NMP for warranty specifications
- "Oil Canning" is an inherent characteristic of roof and wall products, and not a defect, which is not a cause for panel rejection

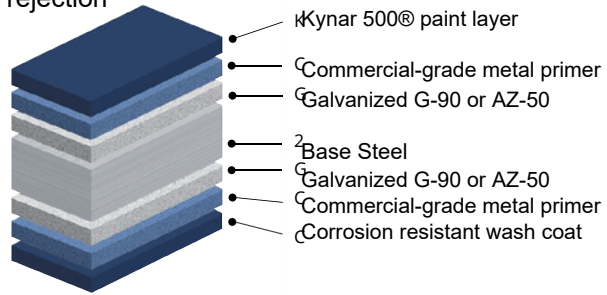

STANDARD COOL KYNAR 500® COLORS

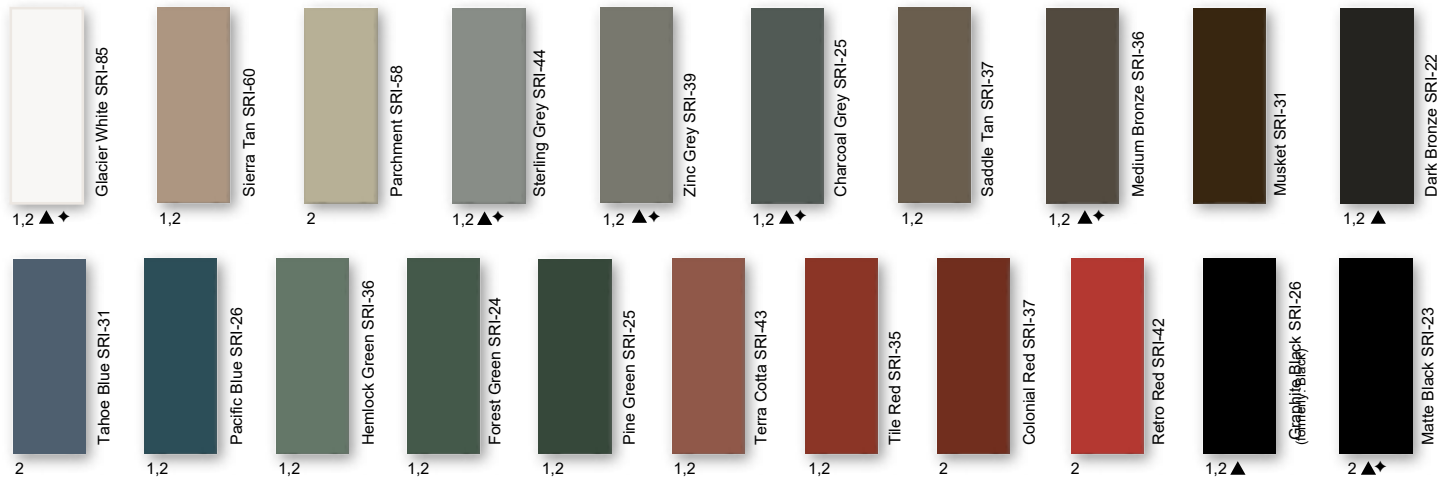

PREMIUM METALLIC COOL KYNAR® COLORS

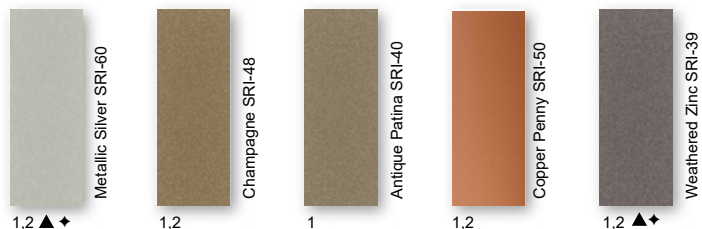

SPECIALIZED MATERIAL

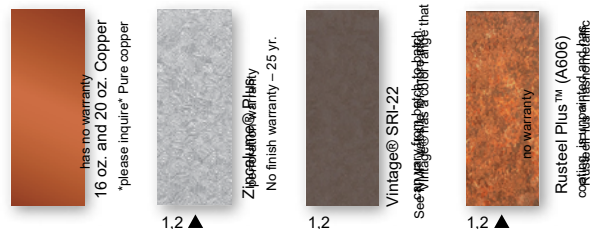

These printed chips provide a close representation of the colors.

Metal samples are available upon request. Coatings are low gloss 10-15% sheen. SRI = Solar Reflective Index. SRI values listed above are in accordance with ASTM E1980 and are based on actual testing. ***Oil canning is not a cause for material rejection***



Revision 01/26

Delivery Fleet

Nor-Cal Metal Products prides itself with quick lead times delivered with our fleet of semi trucks. Our fleet of trucks are owned and operated by NMP. All of our drivers are Nor-Cal Metal Products employees, so when your truck rolls in to deliver, you are dealing with Nor-Cal Metal Products.

Expect consistent and exceptional service with short lead times. The inhouse fleet allows for efficient and cost-effective delivery.



Mounted on the rear of a carrier vehicle, the truck-mounted "piggy-back" forklift will accompany you right to your place of use, opening up unprecedented possibilities in terms of transportation. It can travel sideways, carrying panels up to 40' long, allowing delivery in locations that would typically be considered impossible to reach.

Save time and effort while avoiding potential loading and transport issues; have experienced NMP personnel deliver and unload your order.



Delivery

We will make every attempt to deliver material to the desired location. We may be unable to gain access on tight corners or steep terrain. If the site is deemed inaccessible by our driver, the customer may choose an alternate delivery site within a reasonable proximity. If we are unable to make the alternate delivery, additional charges may be assessed.

The customer is responsible for:

- Determining adequate access for delivery ahead of time.
- Meeting the delivery at the agreed upon time.
- Providing adequate resources (1-4 people as needed) for off loading materials.
- **A charge of \$100 per hour maybe added for deliveries that go beyond their allotted time**
- Check the shipment at the time of delivery.
- Verify material quantities against the shipping/packing list.
- Note any damage or discrepancies upon the paper work at the time of delivery and notify Nor-Cal Metal Products within 48 hours of delivery.

Delivery times are usually scheduled one day in advance. Nor-Cal Metal Products will make every effort to make the delivery at the scheduled time. Please be aware that there may be conditions beyond our control such as traffic, mechanical failures, road closures, etc. which may affect our schedule.

Will Call/Loading

Flatbed trailers and trucks are best suited to transport metal roofing materials. These can be loaded from the side with a forklift and tied down in a safe and secure manner.

We are not able to load materials onto vehicles and/or trailers which are not suitable or may be hazardous to load. Please be aware that if we find a vehicle to be inappropriate, we reserve the right to refuse to load your order.

Unacceptable examples include: boat trailers, vans, buses, motor homes, campers and box trailers. Pickup racks which do not have sufficient supports for the weight or are not long enough to support bundles are also unacceptable.

Nor-Cal Metal Products is **not** responsible to tie down loads nor do we provide any tie down materials. Please bring tie downs to secure your load (string or twine are **not** acceptable for this purpose).

Consider having your order delivered on one of our trucks with a piggy back forklift.



Notes to Designer/Installer

Nor-Cal Metal Products is providing the following details as an aid in design. The details in this guide are not inclusive to all design situations. The designer/installer is responsible for modifications and should take into consideration all aspects of the project including climate conditions, such as, snow and wind, as well as, building code requirements, building design, building usage and maintenance requirements.

Installation should be performed only by qualified installers familiar with metal roofing systems and industry standards. For details not shown in this guide, refer to the Sheet Metal and Air Conditioning Contractors National Association (SMACNA) architectural sheet metal manual for proper design. For manufacturer's weather tightness warranties – all details must be preapproved by Nor-Cal Metal Products technical representative.

The Standard gauge for all products in this guide is 24 gauge and the standard finish is Kynar 500®. We recommend specifying all flashings be the same gauge, color, and finish as the panels to ensure long-term durability and color match.

Substrates

Details in the manual are all shown over solid substrate. **Versa-Span™** can be used over spaced purlins (*for open framing applications please inquire*) For solid substrate, **Nor-Cal Metal Products** recommends 5/8" plywood or metal decking. Contact a NMP representative with questions about panel attachment to varying substrates.

Underlayment

For roofs with pitches below 3:12, High Temp Ice and Water shield underlayment must be installed across the entire surface (projects with manufacturer's weathertightness warranties require the NMP private label product). For pitches steeper than (or equal to) 3:12, High Temp Ice and Water is necessary at all perimeter locations, eave, ridge, valley, hips, sidewall, endwall, prow and penetrations. The remaining of the roof's field areas can then be covered with approved synthetic felt. If local codes or specifications require a Class A fire rated assembly, Polystick XFR or Titanium FR (both products are distributed by NMP) must be installed over the entire roof with combustible decks. Follow manufactures instructions carefully for all underlayment installation.

Drag Load Requirements

All panels must be pinned at one end to resist the drag load caused by snow loads, live loads, and the weight of the panel. Drag load is a function of roof slope, actual load and length of panels. Contact **Nor-Cal Metal Products** for specific drag load requirements.

Ventilation/Insulation

It is the responsibility of the designer to determine the material types needed to control condensation and to insulate and ventilate the roof system. Applications over rigid insulation may require blocking for solid attachment and framing the perimeter for installation of perimeter flashings.

Oil Canning

Flat metal surfaces will display waviness commonly referred to as “oil canning.” Oil canning is caused by a variety of conditions. Steel mill tolerances, variations in or uneven substrates and roofing underlayments. Oil canning is a characteristic of metal roofing, not a defect and is not a cause for rejection. **Nor-Cal Metal Products** offers **Versa-Span™** with striations or accent ribs to help minimize oil canning.

Thermal Movement

The Panels and the flashings must be allowed to expand and contract, especially with longer length panels. The panel may need to have a slight gap where the panel hooks the offset cleat to allow for thermal movement of the panels.

Snow Design

The following details do not address all conditions for snow environments. Consult with the designers, engineers, and others for acceptable details to accommodate your project and climate conditions. When possible gutters, valleys, pitch changes or other penetrations should be minimized in snow areas.

All roof penetrations should be located as close to the ridge or “pin point” top of roof. Snow country requires special designs for valleys to accommodate accumulation of snow and ice from uphill panels. Roof design should be considered in snow areas. Roof design should help resist the melting and freezing of snow and ice.

A fit for purpose roof design has the greatest impact on maintaining a damage free roof system in snow areas. Please contact a Nor-Cal Metal Products representative for assistance in detail designs and appropriate panel selection for specific climate and building conditions.

Handling / Storage&Safety

Handle materials with care when off-loading or moving materials to avoid damage to panels or flashings. Long panels may require two or more pick-up points, properly spaced to avoid damaging panels. Plan ahead; contact Nor-Cal Metal Products for recommendations on handling/hoisting long panels.

Store the panels, flashings and accessories in a dry, well ventilated area, off the ground. If covering, allow ventilation around panels. Elevate one end of bundle to allow drainage of wet materials.

Wear clean, soft-soled shoes when walking on roofing panels to avoid damage to the painted finish.

Take care that sand, gravel, dirt, etc. sticking to your shoes is not carried onto the roof, scratching or otherwise damaging the finish on the roofing material. Walking on asphalt impregnated felt paper, especially on a hot day, can cause the asphalt to stick to your shoes and be tracked on to the roofing material.

Take care when painting to avoid getting over spray on the roofing material. Remember that wind can carry paint particles some distance. Over spray can cause the finish of the roofing material to look dull and may void your warranty.

Secure materials, especially when leaving the site, on the ground or roof to prevent winds from moving the materials. Wind-blown materials may cause damage to the material, property or persons.

Always use proper safety equipment and attire to minimize risk of cuts or other injuries.

Do not walk on panels that have not been completely installed.

Do not walk on major ribs of panels.

Metal roofs that are wet or dusty can be extremely slippery. Wear soft soled shoes and a safety harness to minimize risk of falling.

Avoid installing metal panels in windy conditions.

Safety considerations are the responsibility of the installer and his crew. Be sure to **use common sense** and generally accepted safety practices when installing roofing materials.

STANDARD EAVE DETAIL

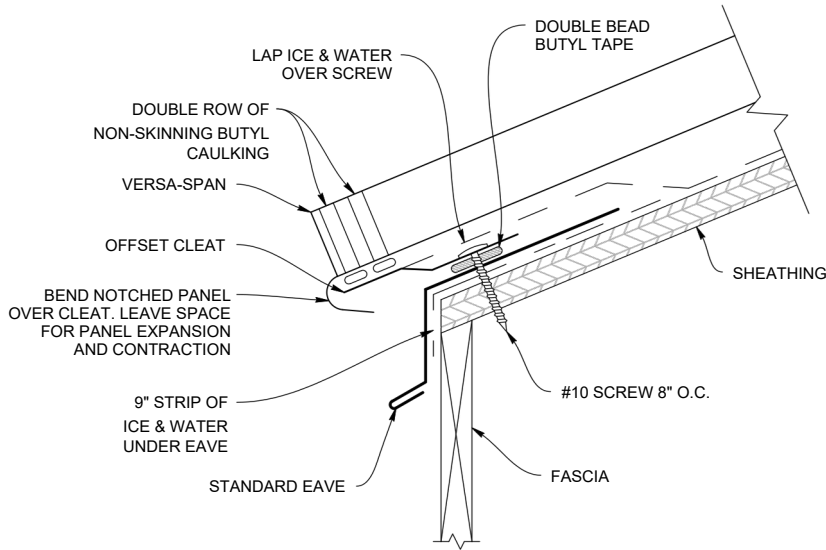

STANDARD EAVE (VSES)

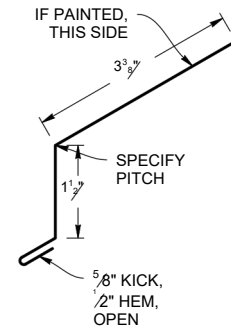

OFFSET CLEAT (VSOC)

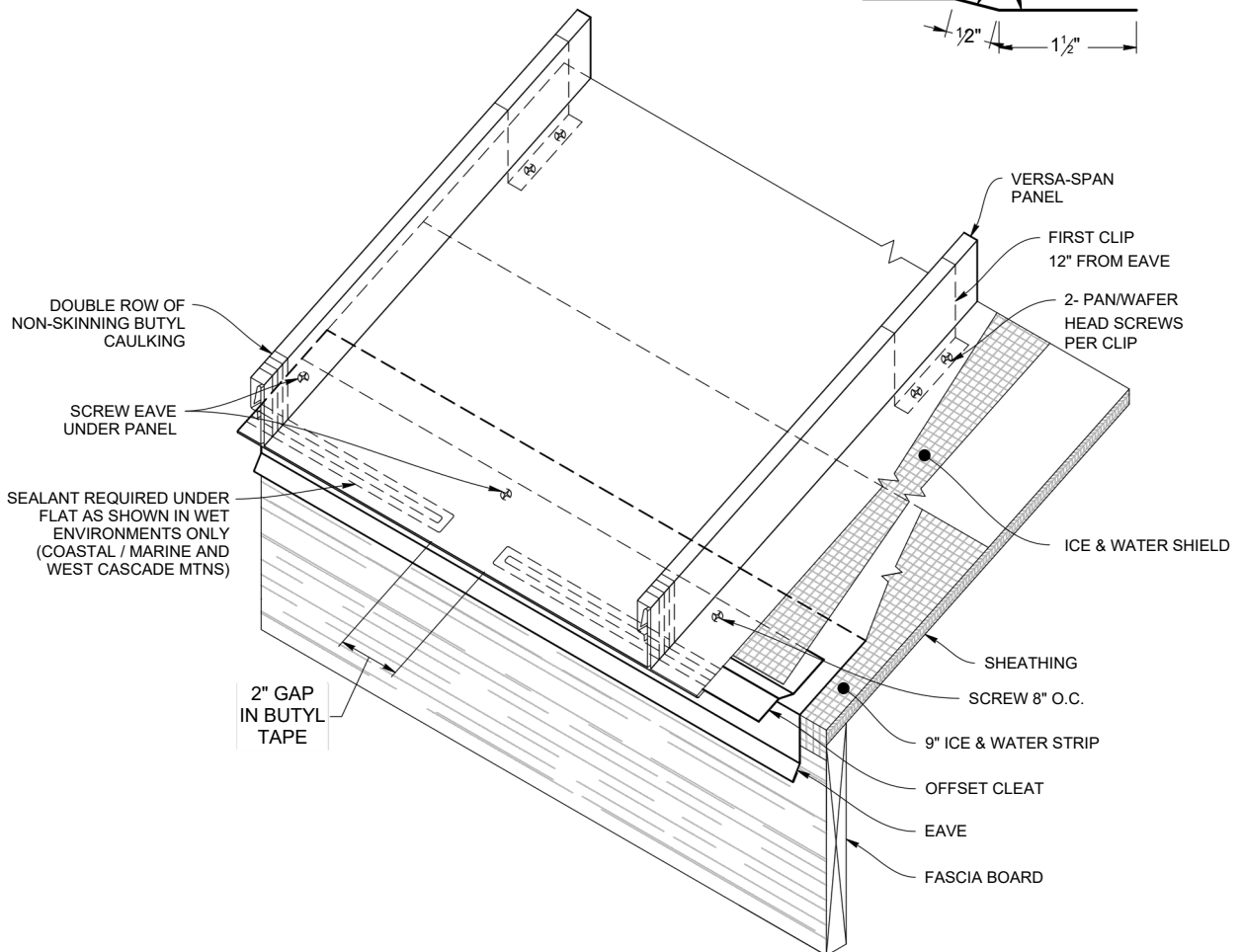
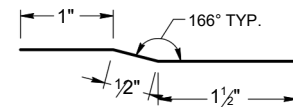

Note: All screws must be fastened into solid substrate.
Flashing must be lapped 4" with 3 rows of sealant.

HOOK EAVE DETAIL

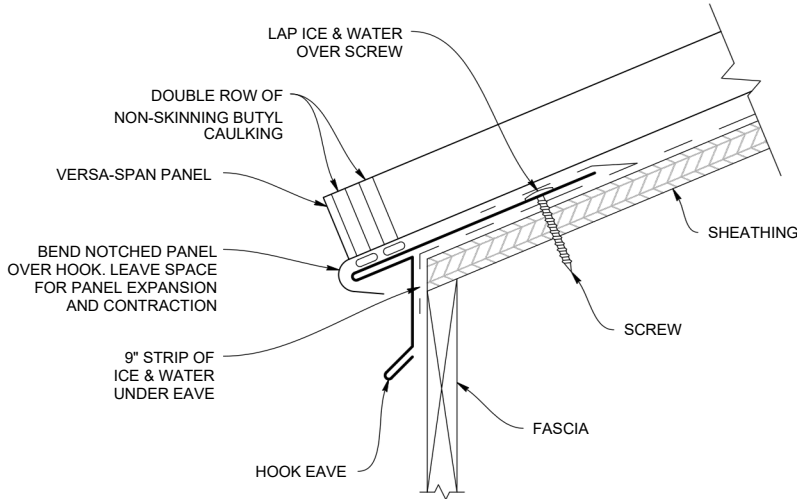

HOOK EAVE (VSEH)

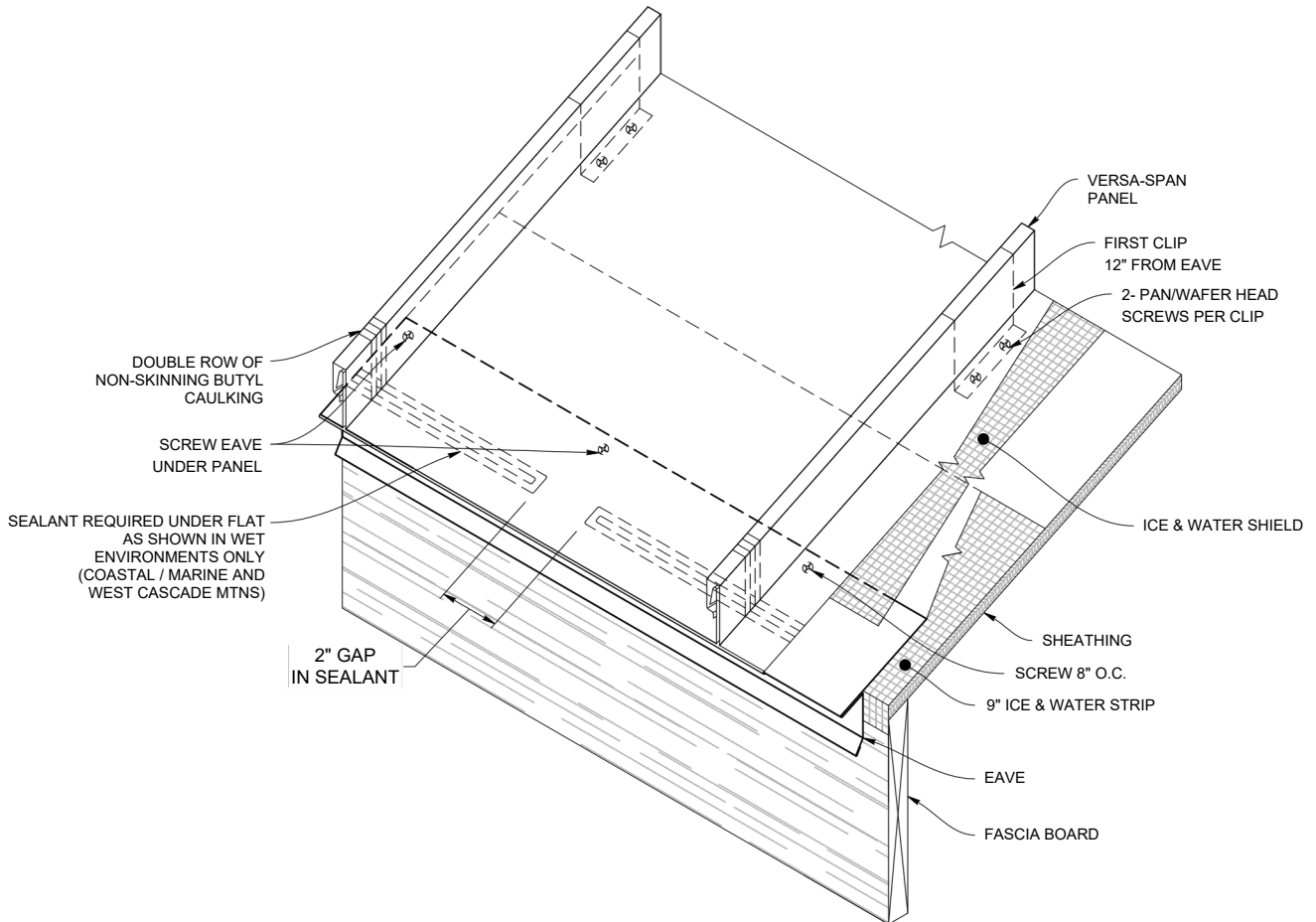
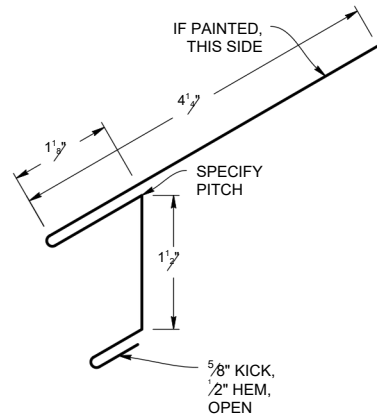

Note: All screws must be fastened into solid substrate.
Flashing must be lapped 4" with 3 rows of sealant.

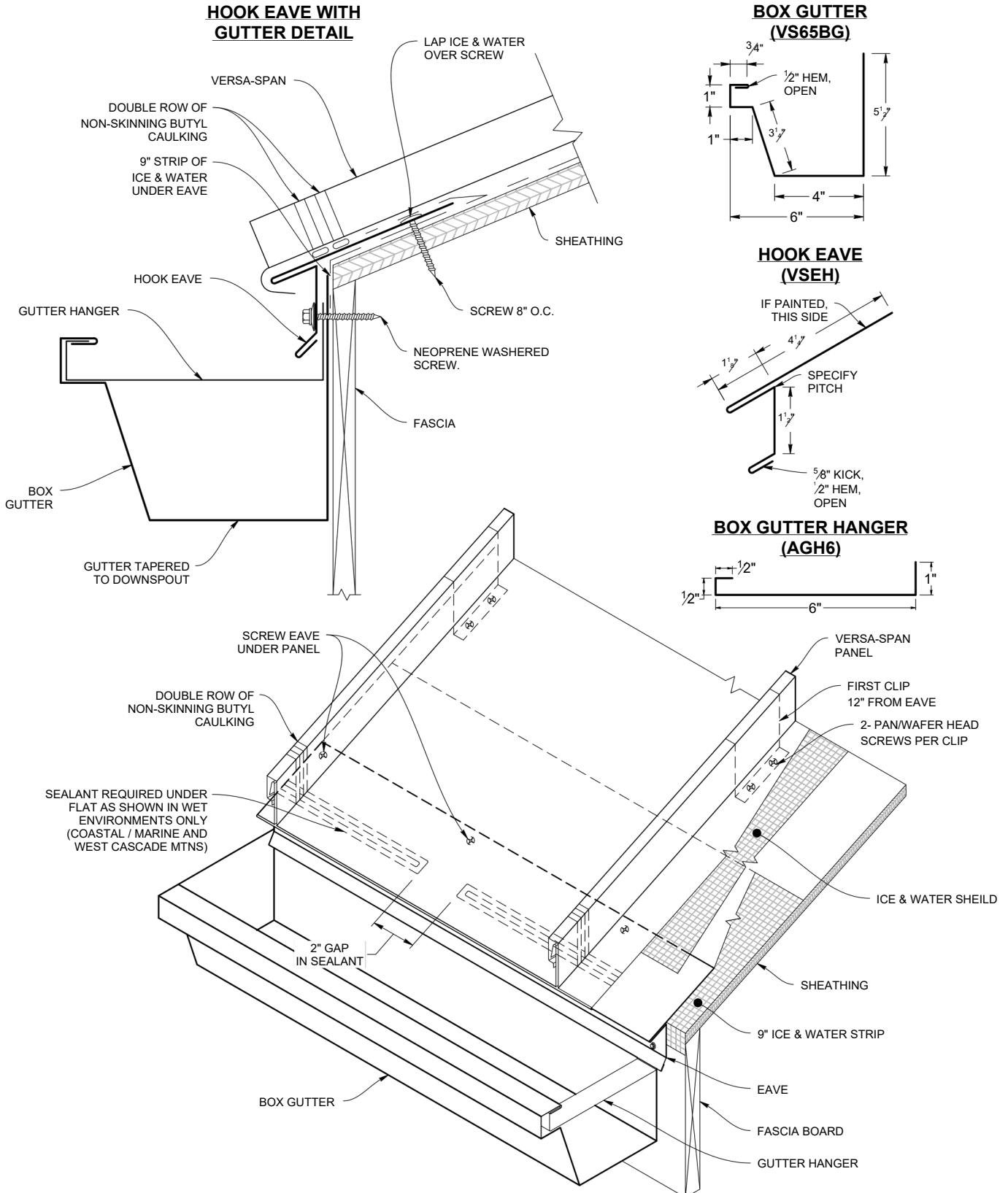

Note: All screws must be fastened into solid substrate.
Flashing must be lapped 4" with 3 rows of sealant.

STANDARD RIDGE DETAIL

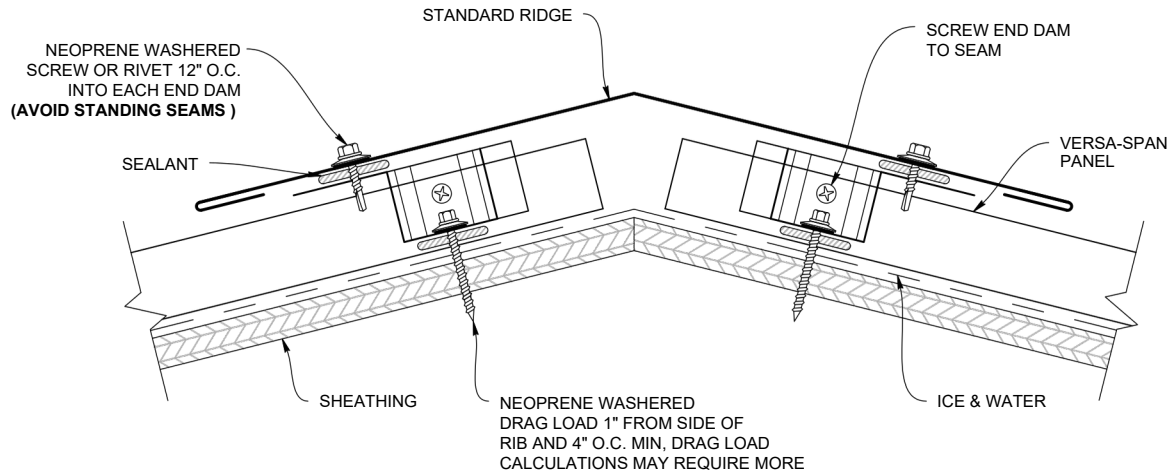

STANDARD RIDGE (VSRs)

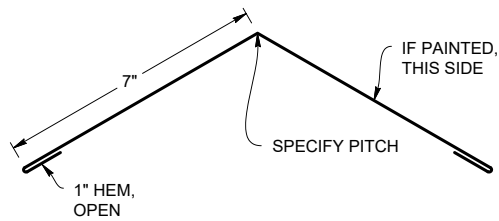

RIDGE LAP

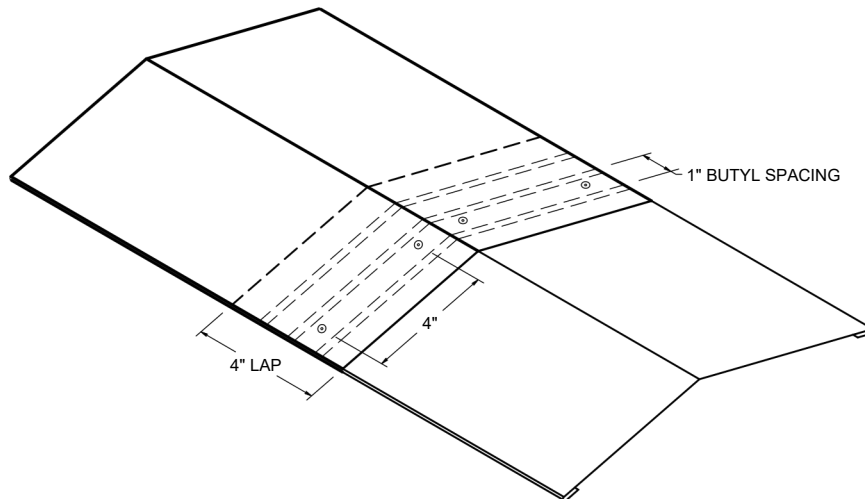

Note: All screws must be fastened into solid substrate. Flashing must be lapped 4" with 3 rows of sealant.

WT RIDGE VENTED DETAIL

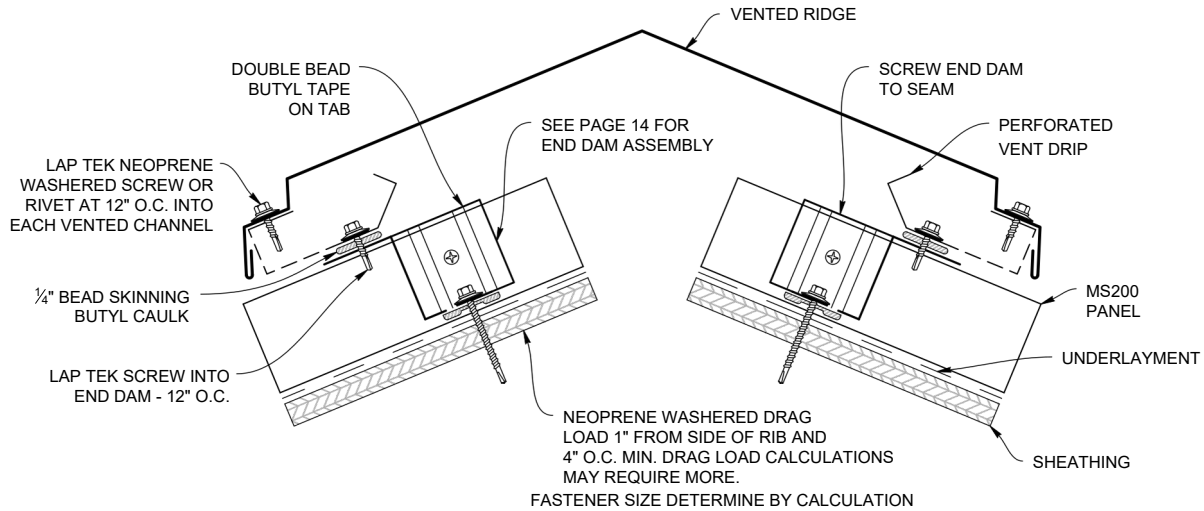

WT RIDGE VENTED (VSWTRFV)

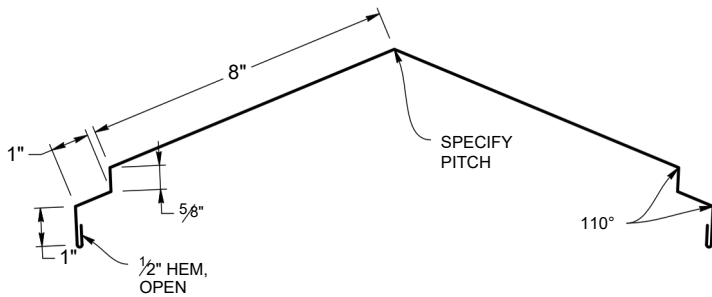

PERFORATED VENT DRIP: E2886 EMBER RESISTANT (VSPVD)

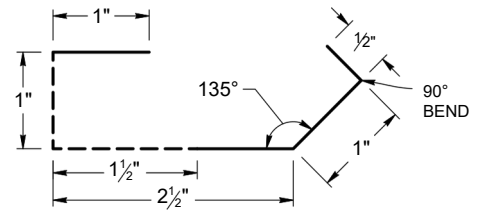

****NOTE: PERFORATED VENT DRIP IS COMPATIBLE WITH WT VENTED FLASHINGS ONLY****

****14.5" Freeairper LFT for Ridge****

RIDGE LAP

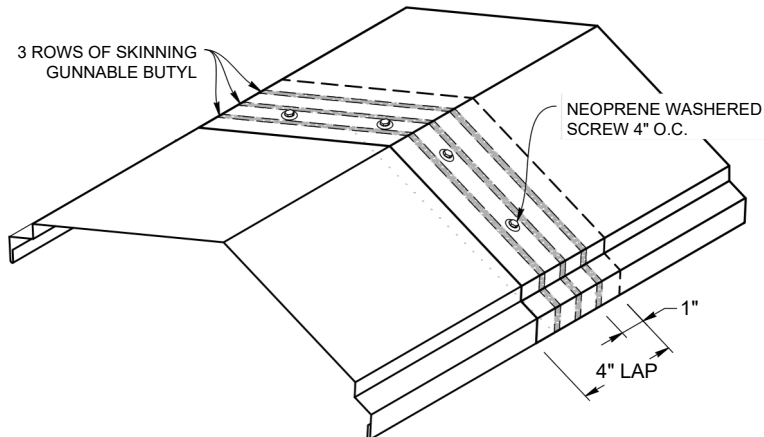

Note: All screws must be fastened into solid substrate.
Flashing must be lapped 4" with 3 rows of sealant.

END DAM ATTACHMENT APPLICATION

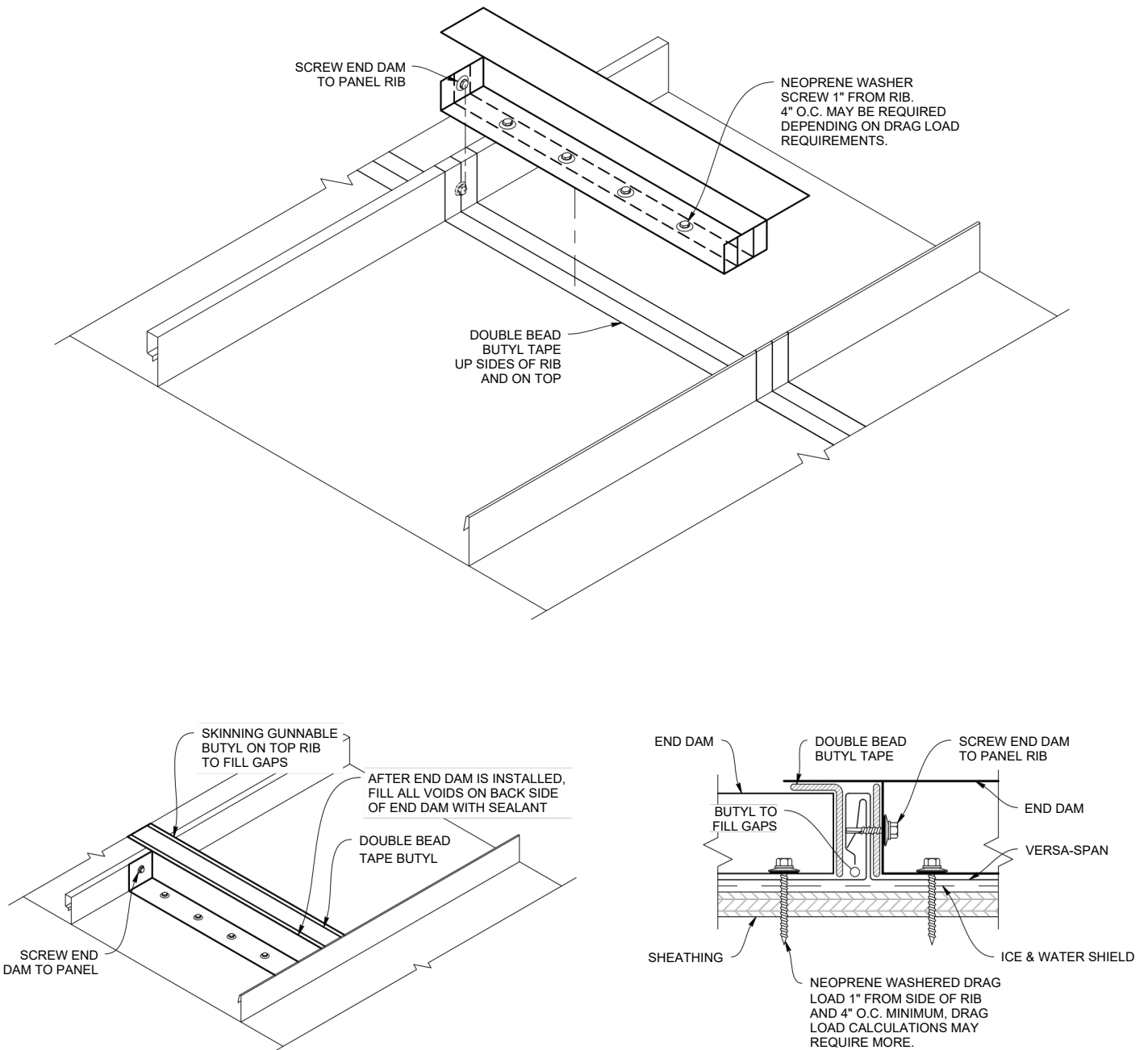

Note: All screws must be fastened into solid substrate.
Flashing must be lapped 4" with 3 rows of sealant.

OFFSET CLEAT (VSOC)

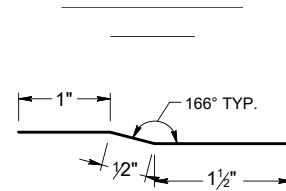

VALLEY 24" FLASHING (VSVF)

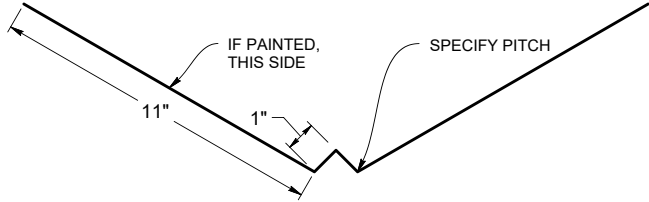

VALLEY 24" DETAIL (2:12 or Greater Pitch)

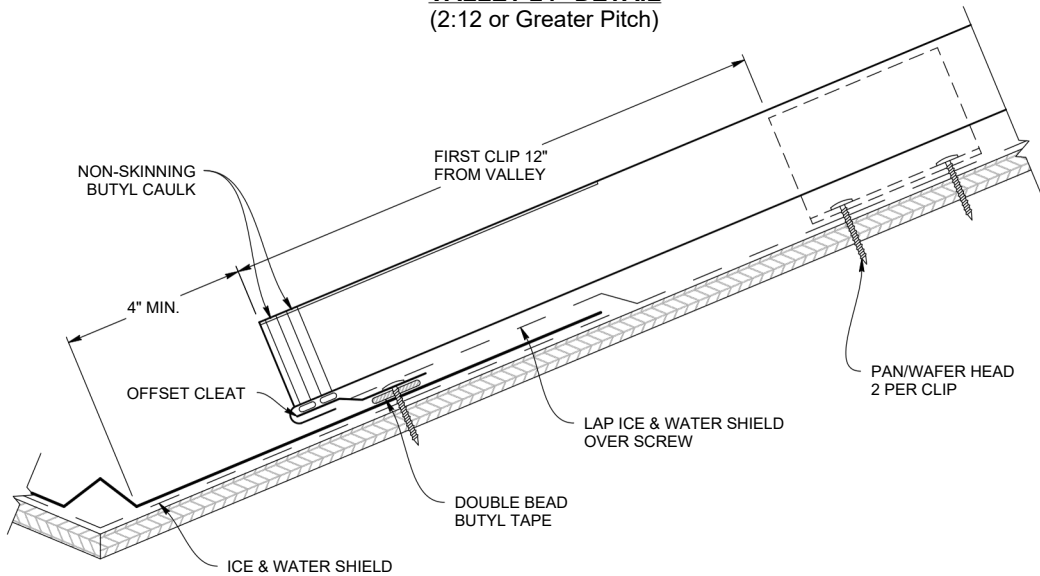

VALLEY LAP (2:12 or Greater Pitch)

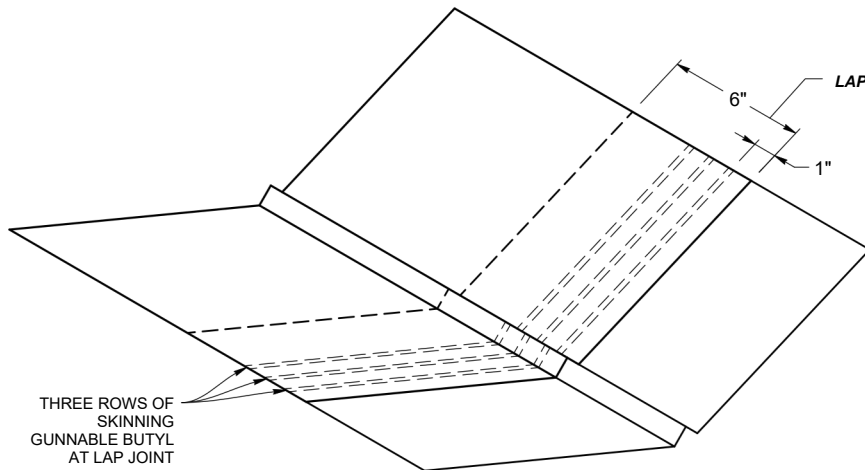

Note: All screws must be fastened into solid substrate. Flashing must be lapped 4" with 3 rows of sealant.

LOW SLOPE VALLEY DETAIL
(Less Than 2:12 Pitch - Not Recommended)

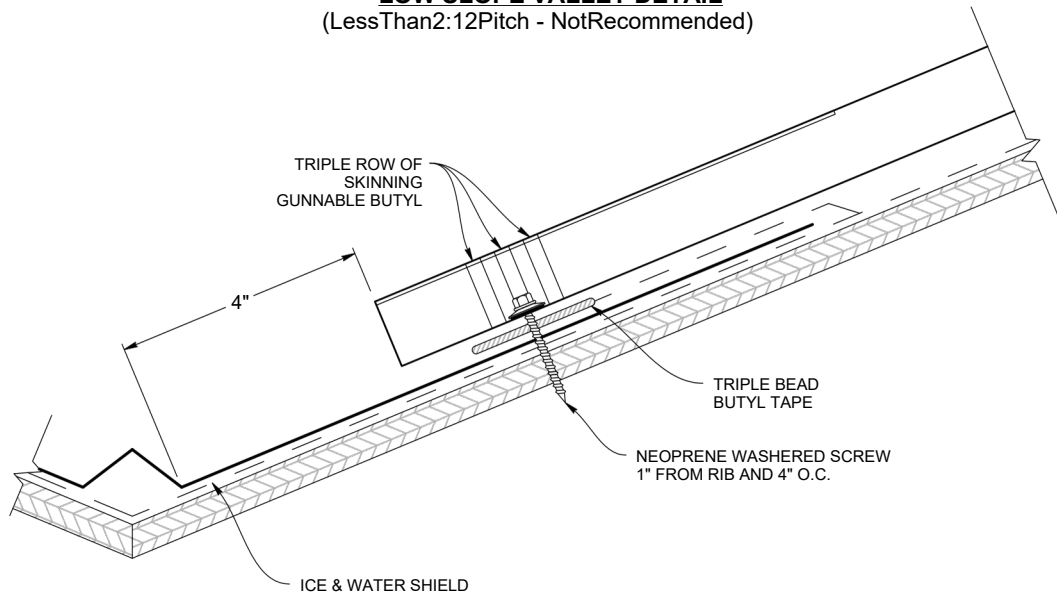

VALLEY FLASHING (VSVF)

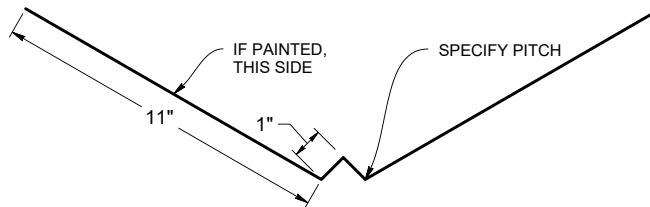

LOW SLOPE VALLEY LAP
(Less Than 2:12 Pitch - Not Recommended)

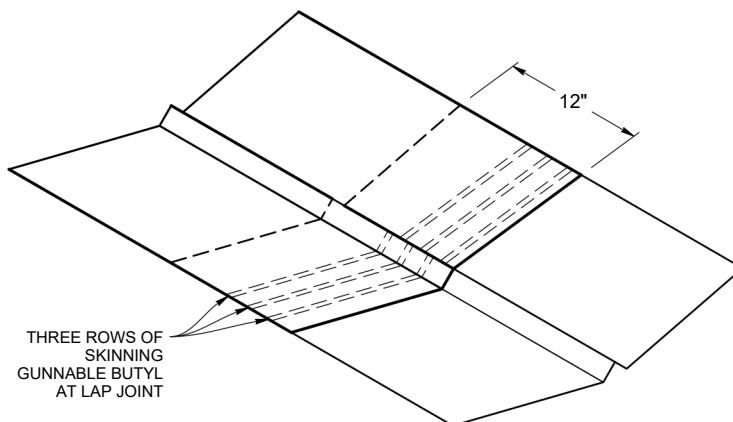

Note: All screws must be fastened into solid substrate.
Flashing must be lapped 4" with 3 rows of sealant.

STANDARD GABLE DETAIL

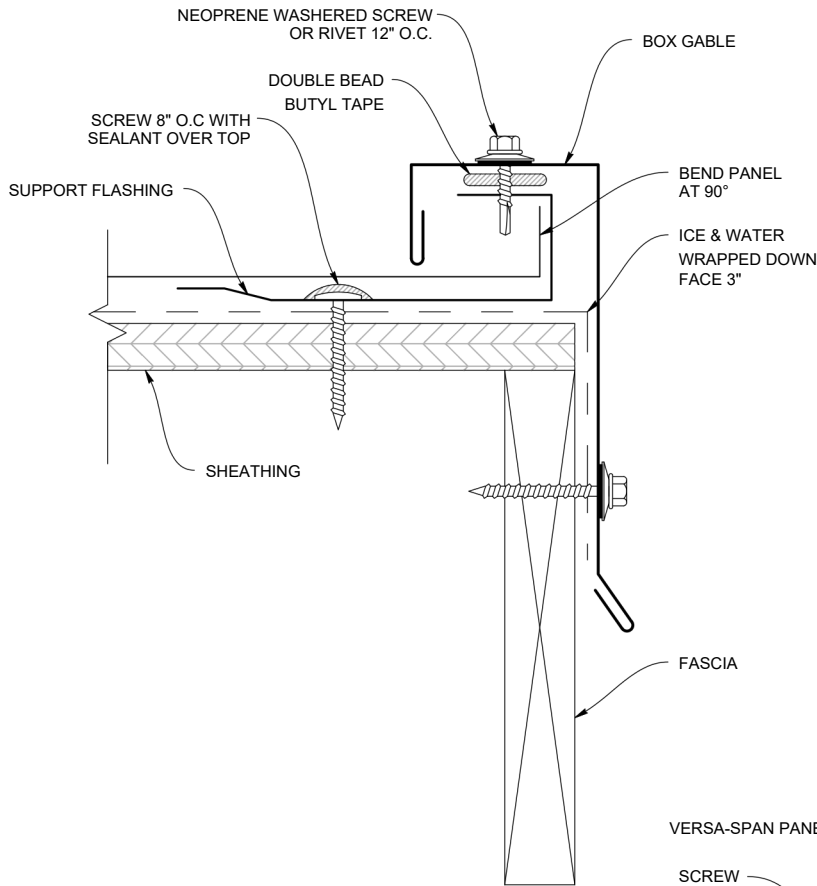

BOX GABLE (VSGB)

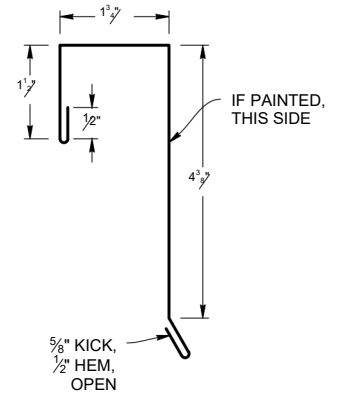

SUPPORT FLASHING (VSSF)

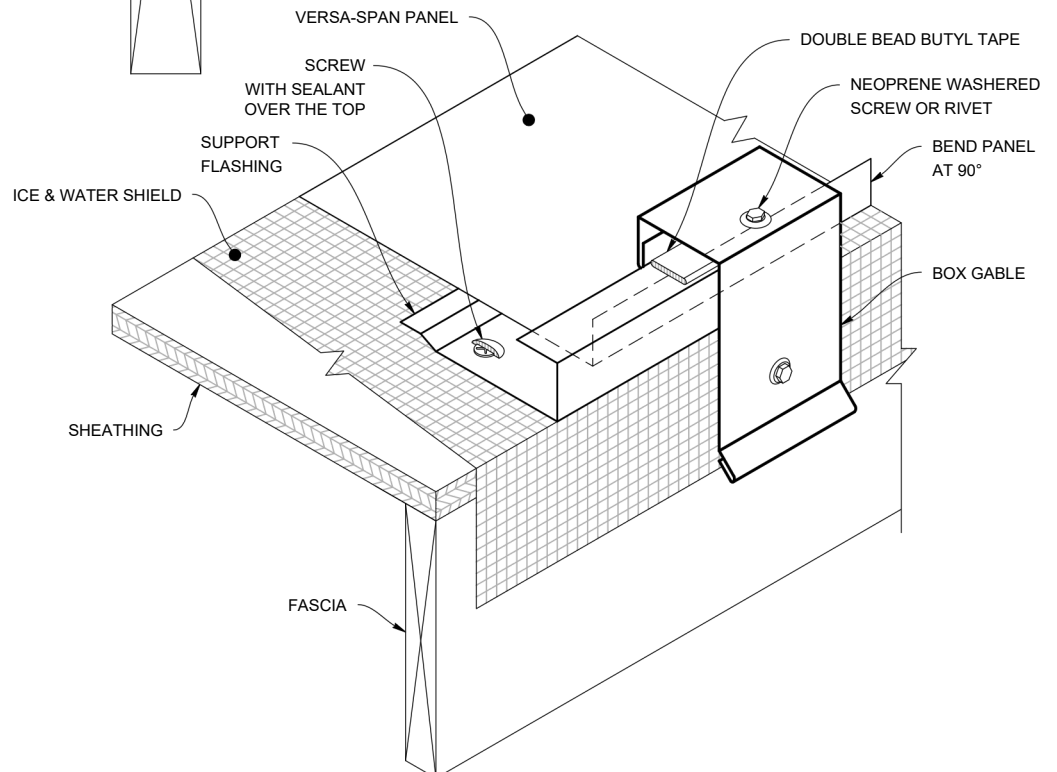
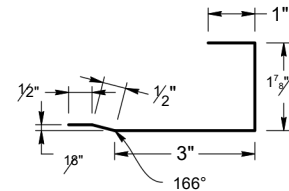

Note: All screws must be fastened into solid substrate.
 Flashing must be lapped 4" with 3 rows of sealant.

ALTERNATE GABLE DETAIL

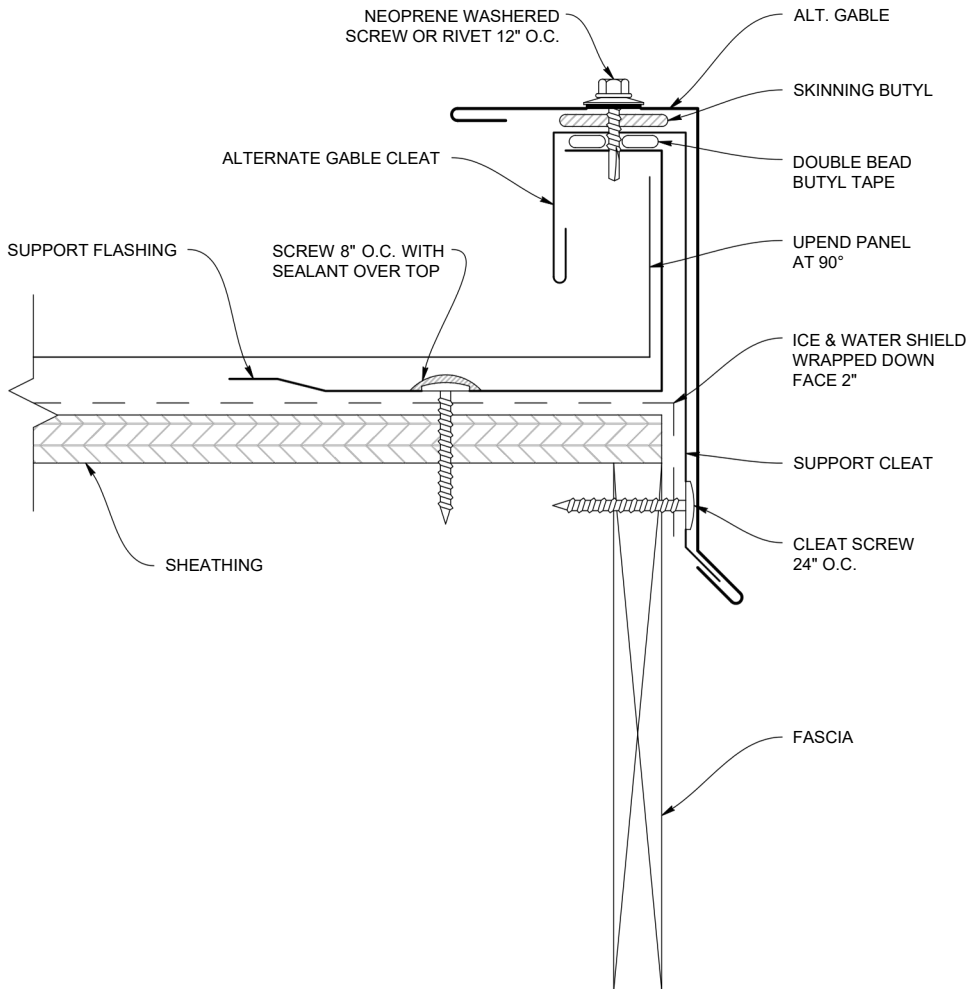

ALTERNATE GABLE (VSAG)

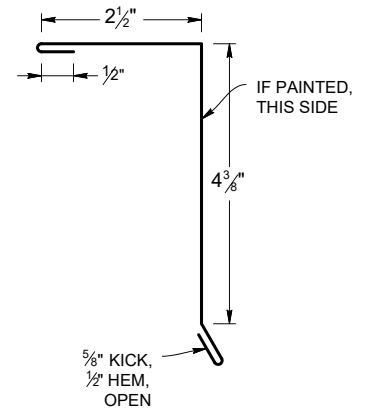

ALTERNATE GABLE CLEAT (VSAGC)

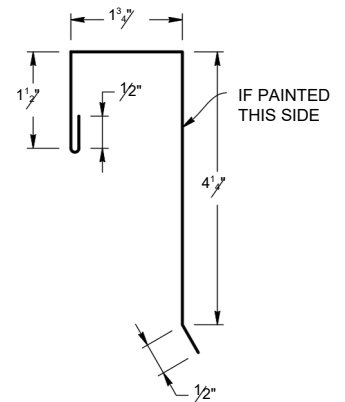

SUPPORT FLASHING (VSSF)

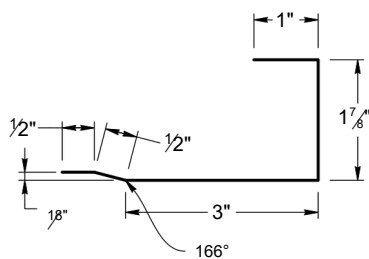

Note: All screws must be fastened into solid substrate.
Flashing must be lapped 4" with 3 rows of sealant.

SIDEWALL DETAIL

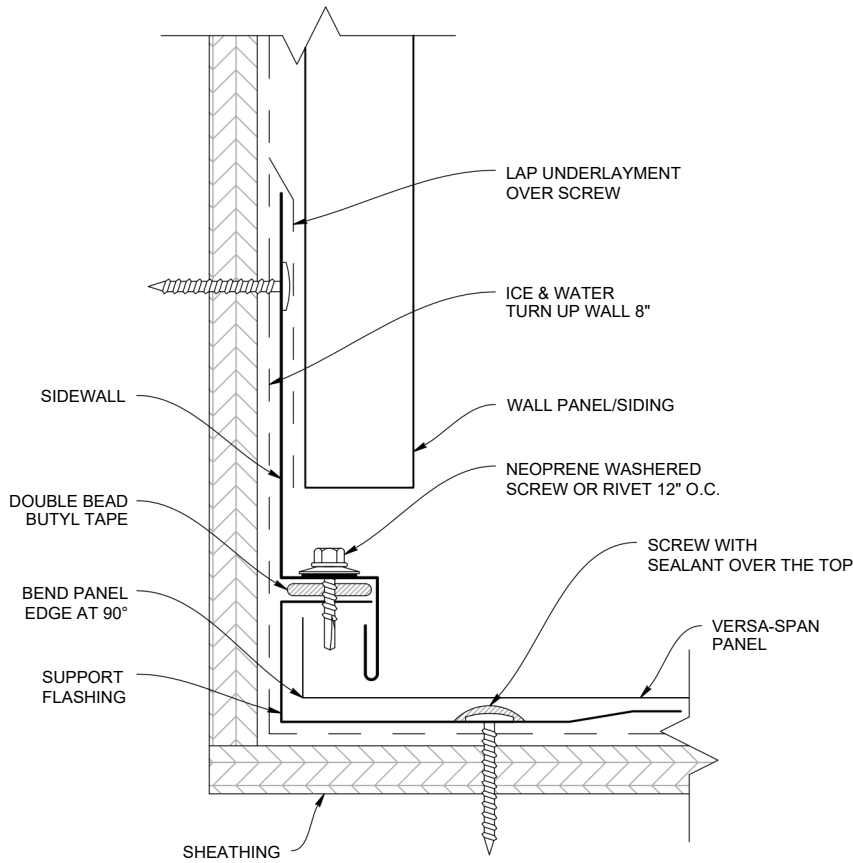

SIDEWALL (VSSW)

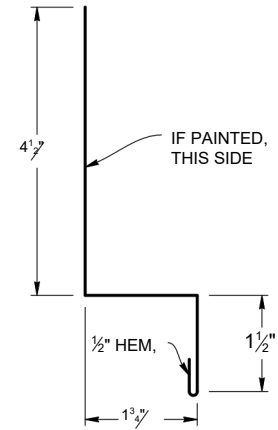

SUPPORT FLASHING (VSSF)

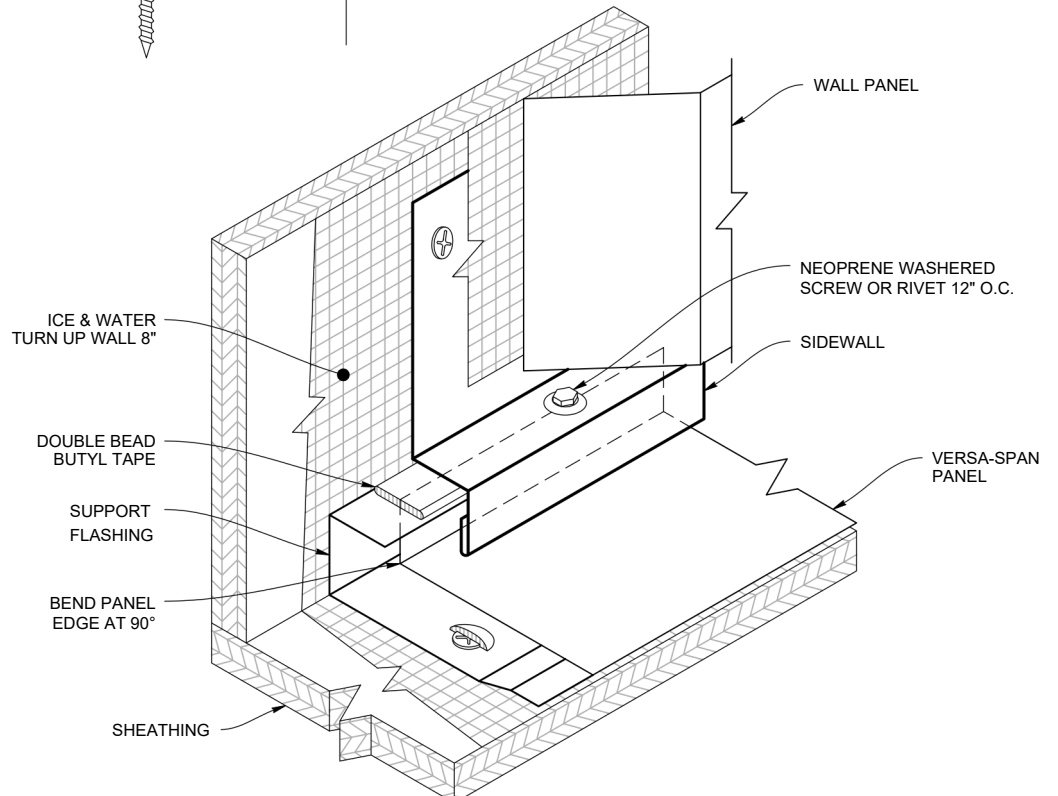
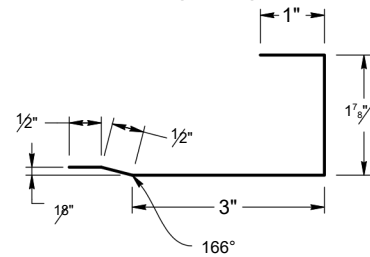

Note: All screws must be fastened into solid substrate.
Flashing must be lapped 4" with 3 rows of sealant.

PEAK FLASHING DETAIL (Ridge End Cap)

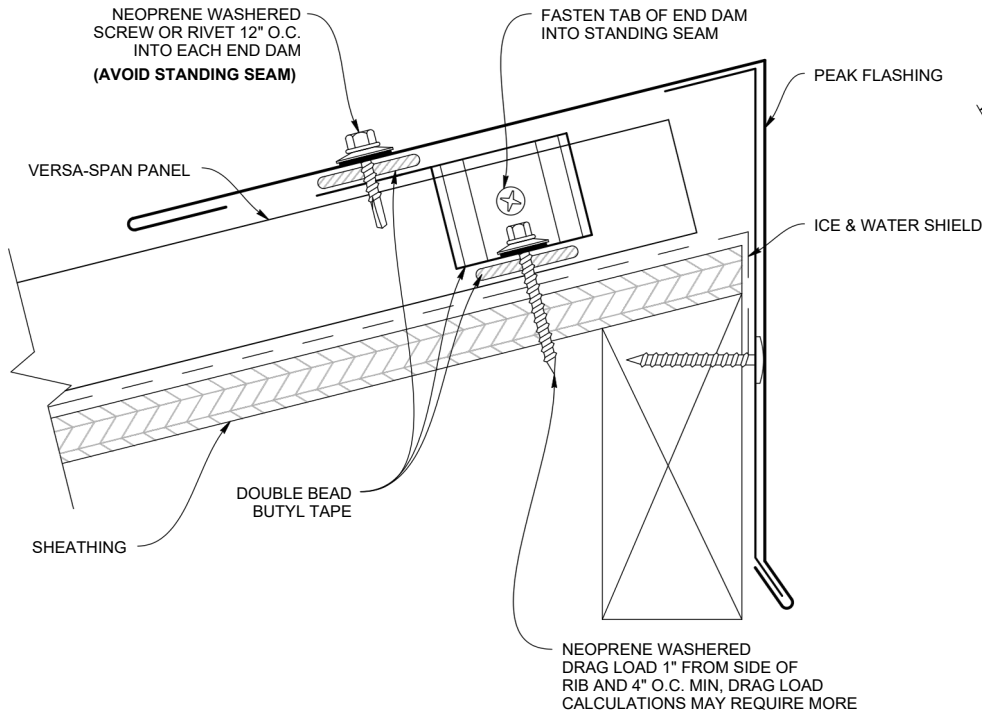

PEAK FLASHING (Ridge End Cap) (VSREC)

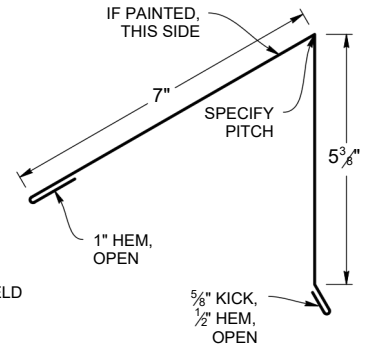

PEAK CLEAT (VSRECC)

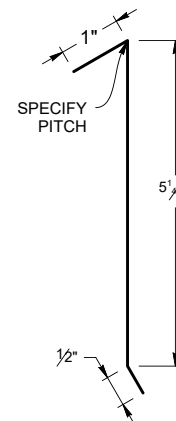

PEAK FLASHING LAP

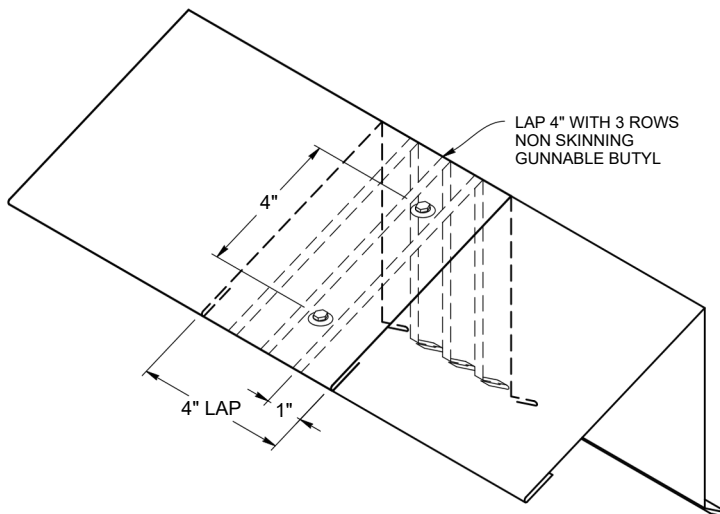

Note: All screws must be fastened into solid substrate. Flashing must be lapped 4" with 3 rows of sealant.

WT VENTED PEAK FLASHING DETAIL (RidgeEndCap)

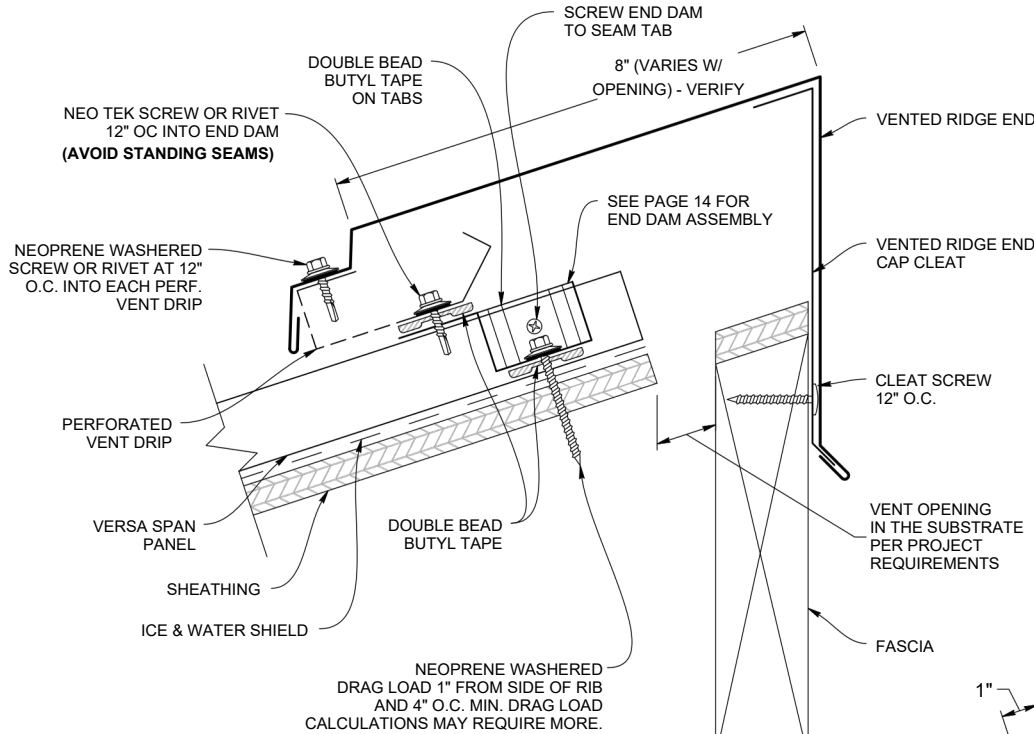

VENTED PEAK CLEAT (VSVRECC)

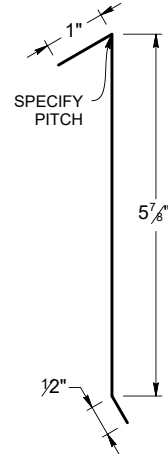

WT VENTED PEAK FLASHING (VSWTREC V)

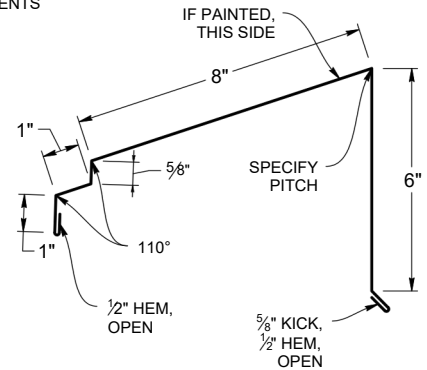

VENTED PEAK FLASHING LAP

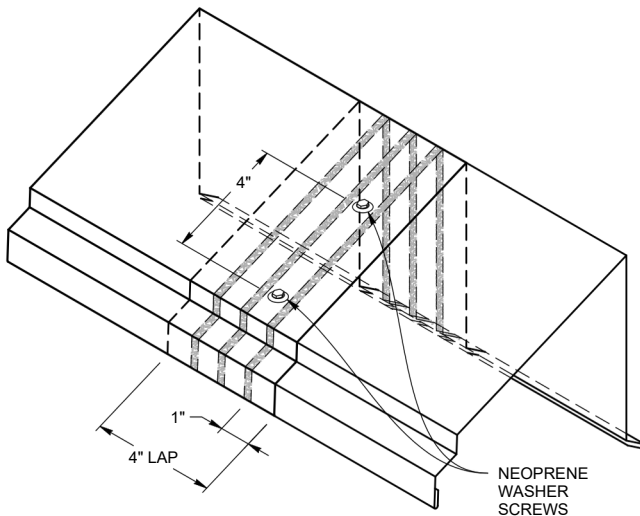

PERFORATED VENT DRIP: E2886 EMBER RESISTANT (VSPVD)

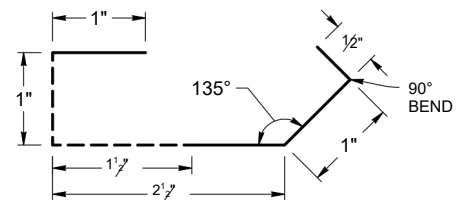

NOTE: PERFORATED VENT DRIP IS COMPATIBLE WITH WT VENTED FLASHINGS ONLY

7.25" Freeairper LFT for Ridge

Note: All screws must be fastened into solid substrate. Flashing must be lapped 4" with 3 rows of sealant.

PITCH CHANGE DETAIL

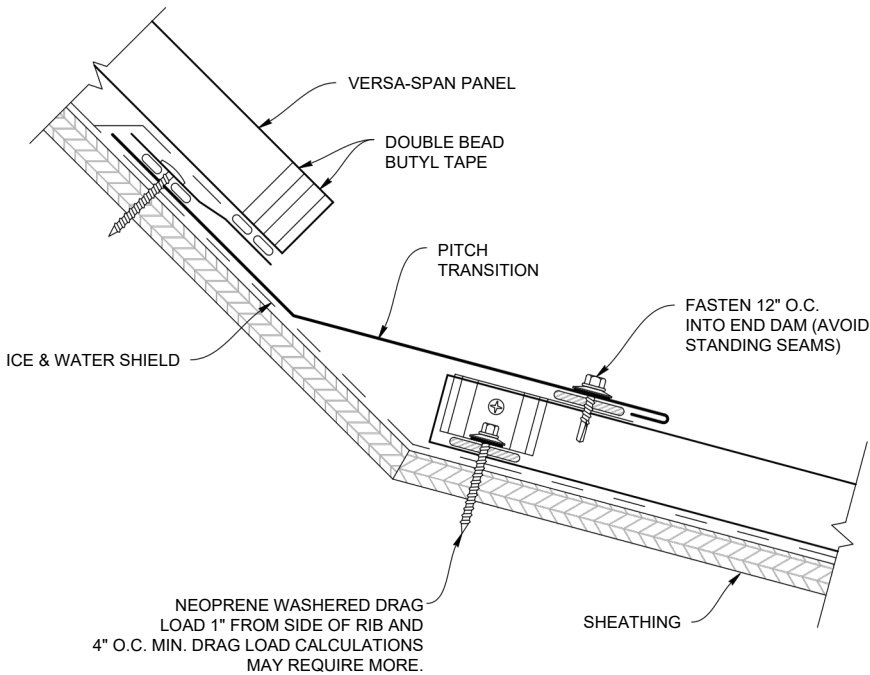

INSIDE PITCH CHANGE FLASHING (SLPCIN)

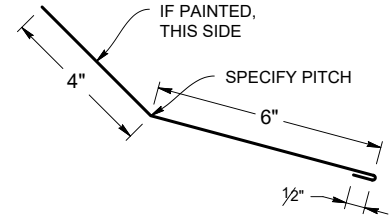

OFFSET CLEAT (VSOC)

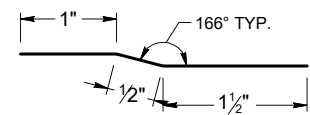

PITCH CHANGE LAP

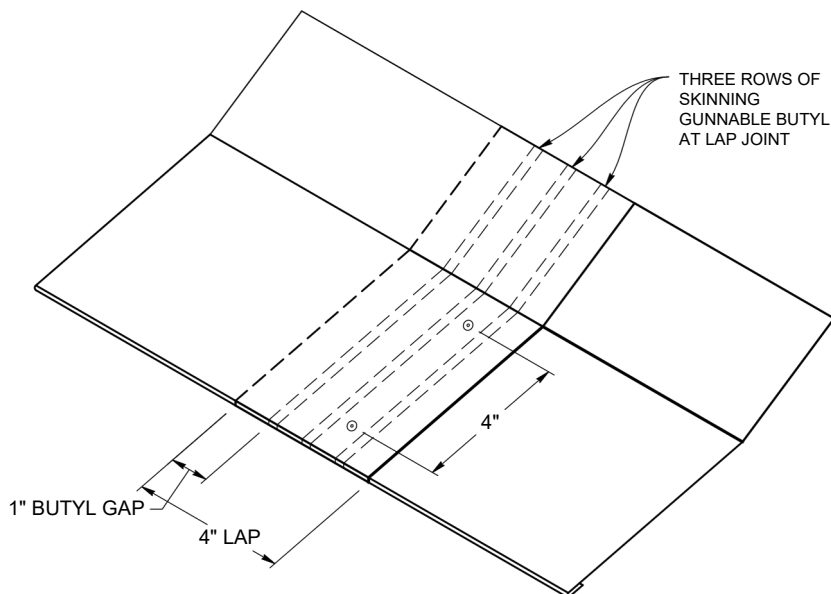

Note: All screws must be fastened into solid substrate.
Flashing must be lapped 4" with 3 rows of sealant.

ENDWALL DETAIL

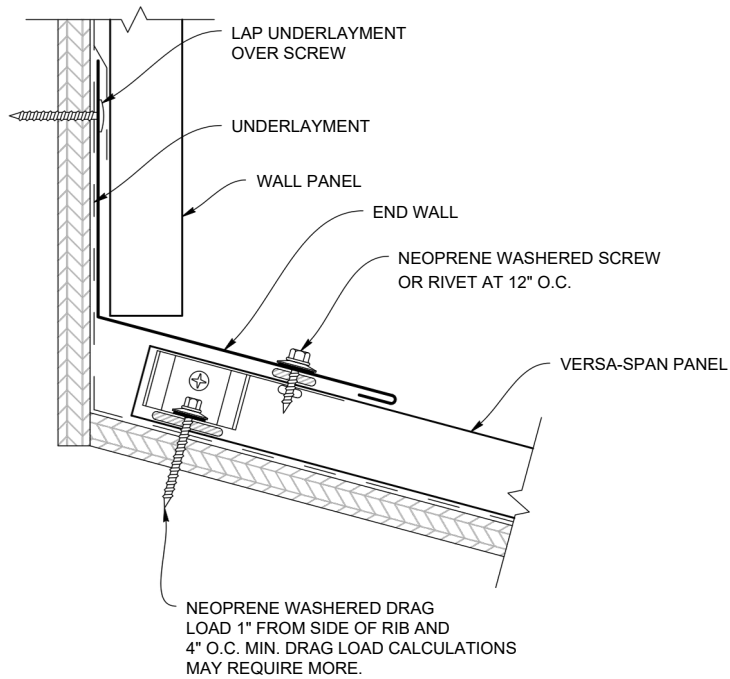

ENDWALL FLASHING (VSEW)

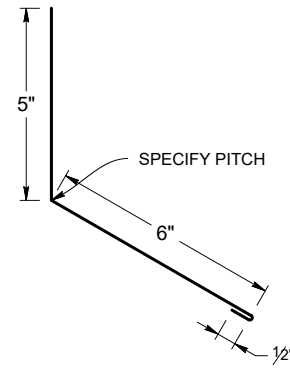

ENDWALL LAP

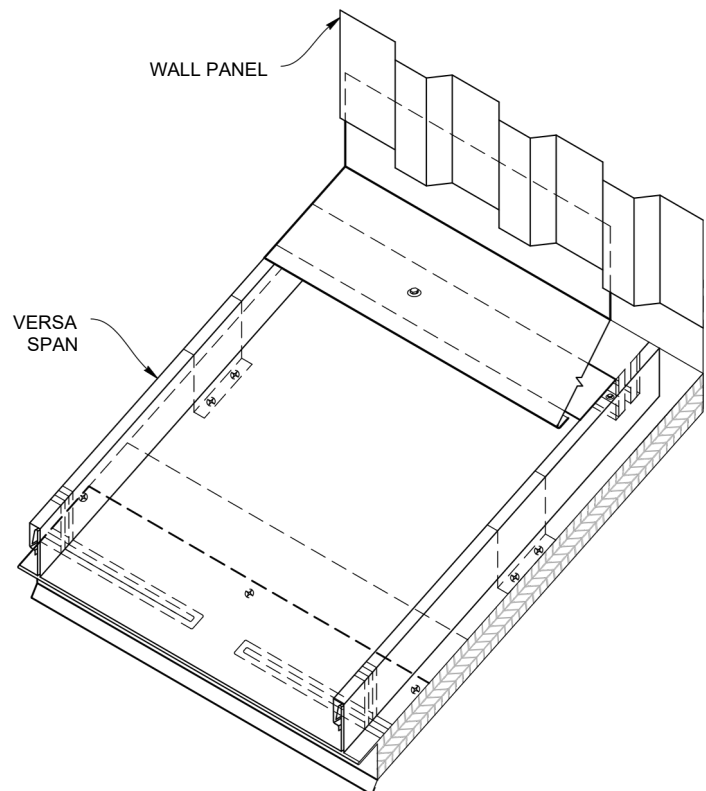
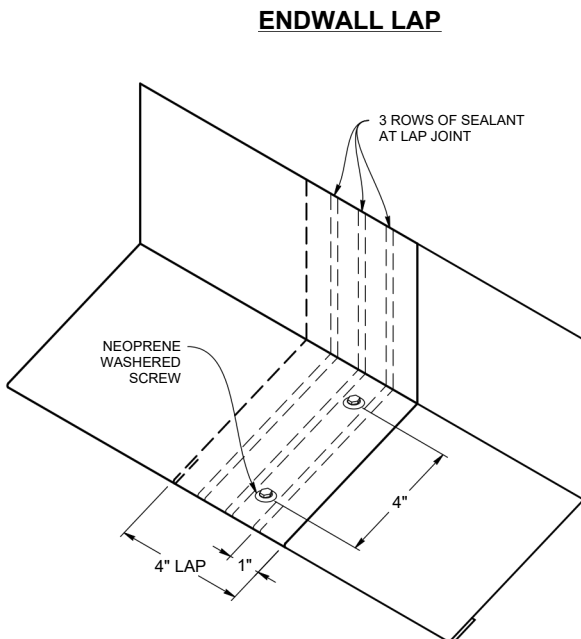

Note: All screws must be fastened into solid substrate.
Flashing must be lapped 4" with 3 rows of sealant.

WT VENTED ENDWALL DETAIL

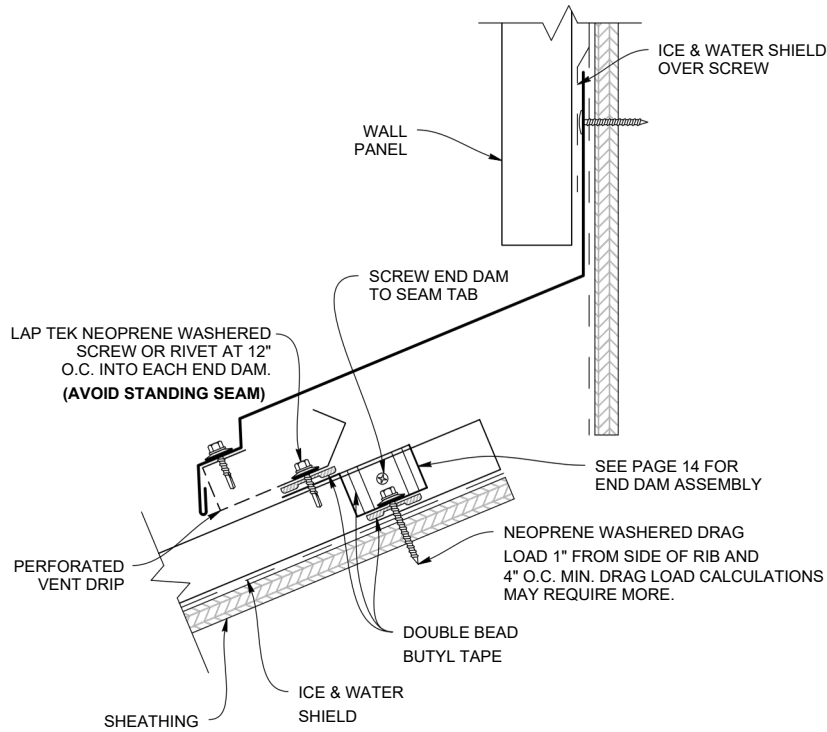

WT VENTED ENDWALL FLASHING (VSWTEWV)

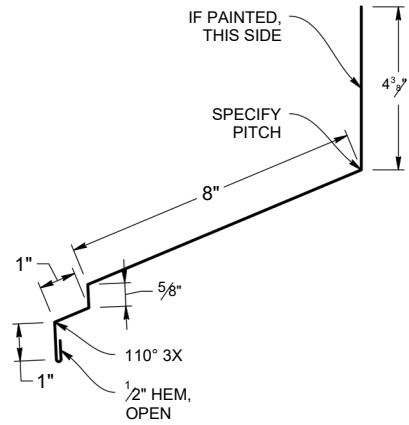

PERFORATED VENT DRIP: E2886 EMBER RESISTANT (VSPVD)

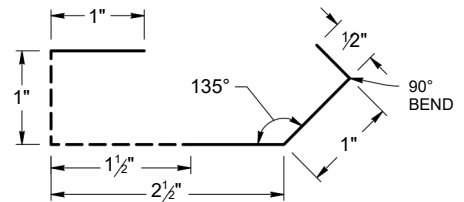

****NOTE: PERFORATED VENT DRIP IS COMPATIBLE WITH WT VENTED FLASHINGS ONLY****

****7.25" Freeairper LFT for Ridge****

VENTED ENDWALL LAP

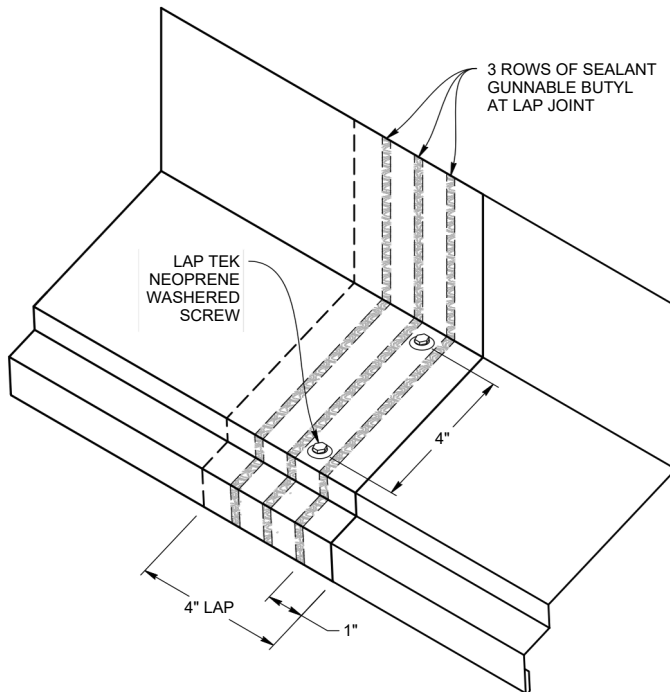

Note: All screws must be fastened into solid substrate. Flashing must be lapped 4" with 3 rows of sealant.

SAW CUT ENDWALL DETAIL

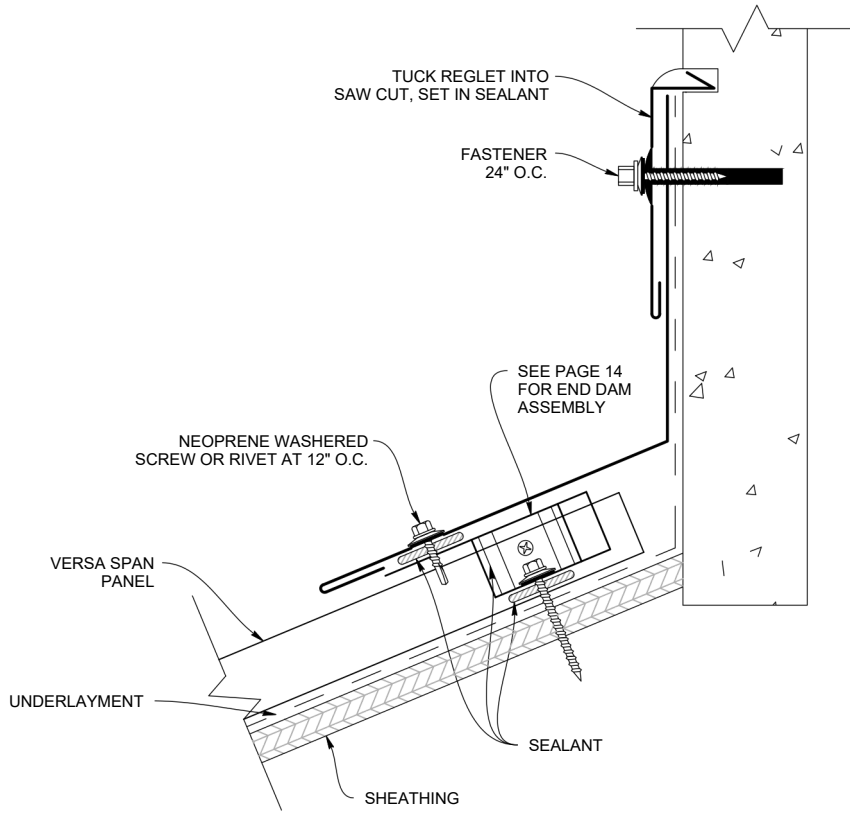

ENDWALL FLASHING (VSEWV)

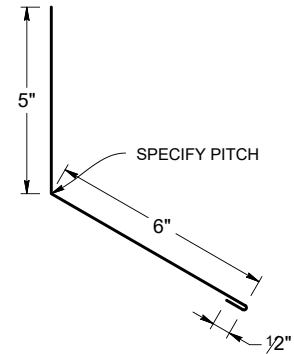

ENDWALL LAP

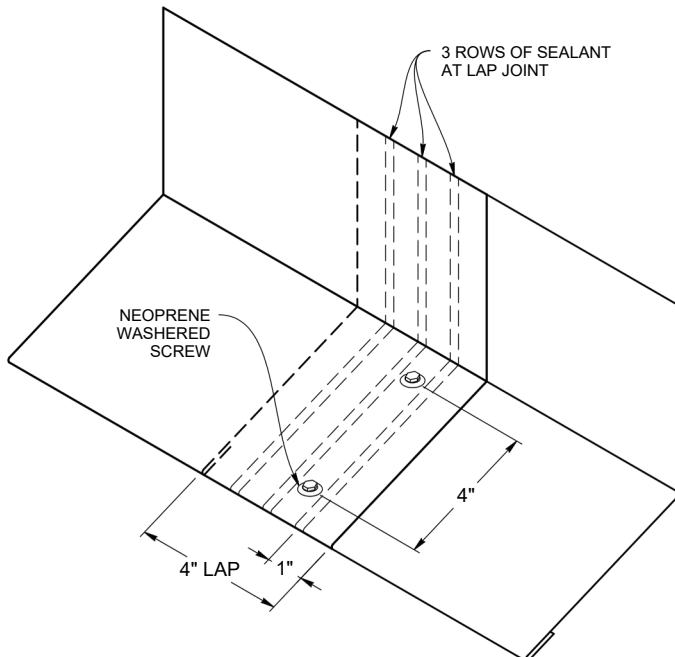

REGLET (VSRF)

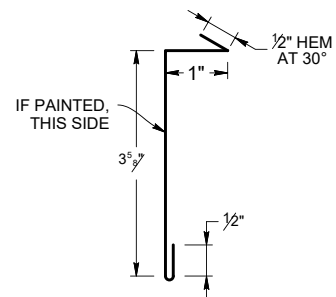

Note: All screws must be fastened into solid substrate. Flashing must be lapped 4" with 3 rows of sealant.

STEP 1

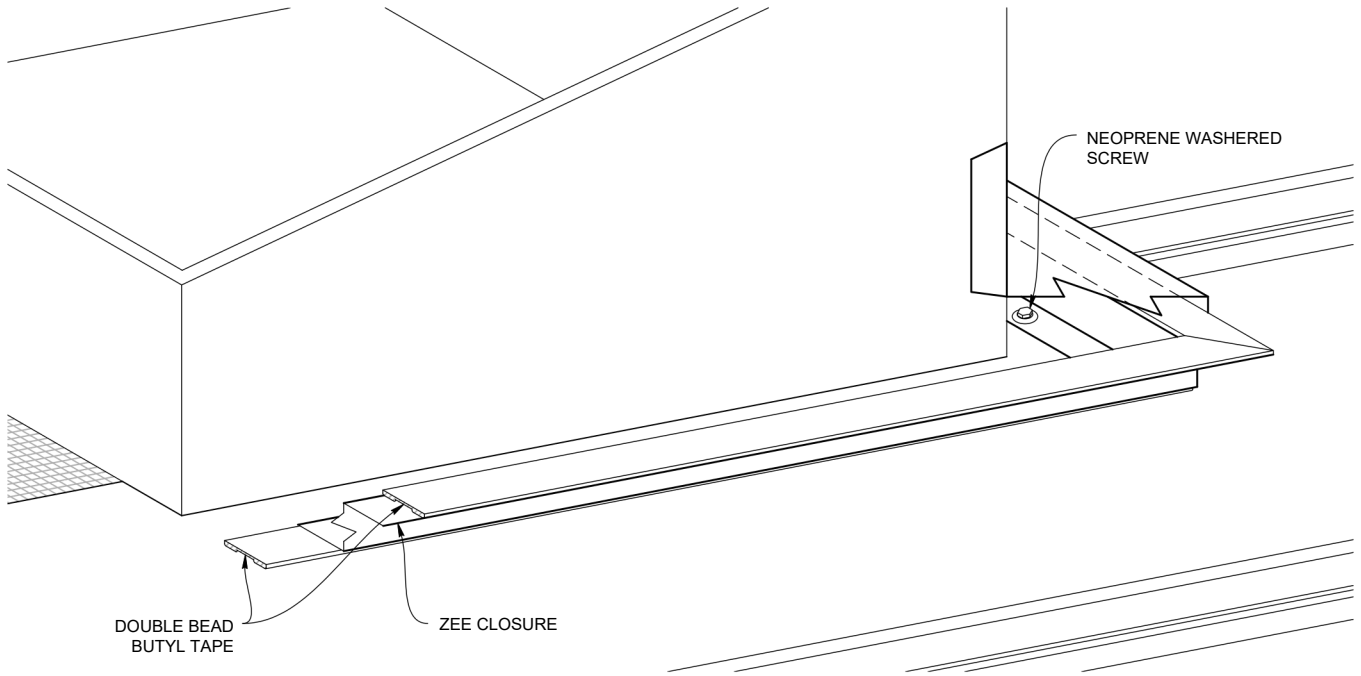

STEP 2

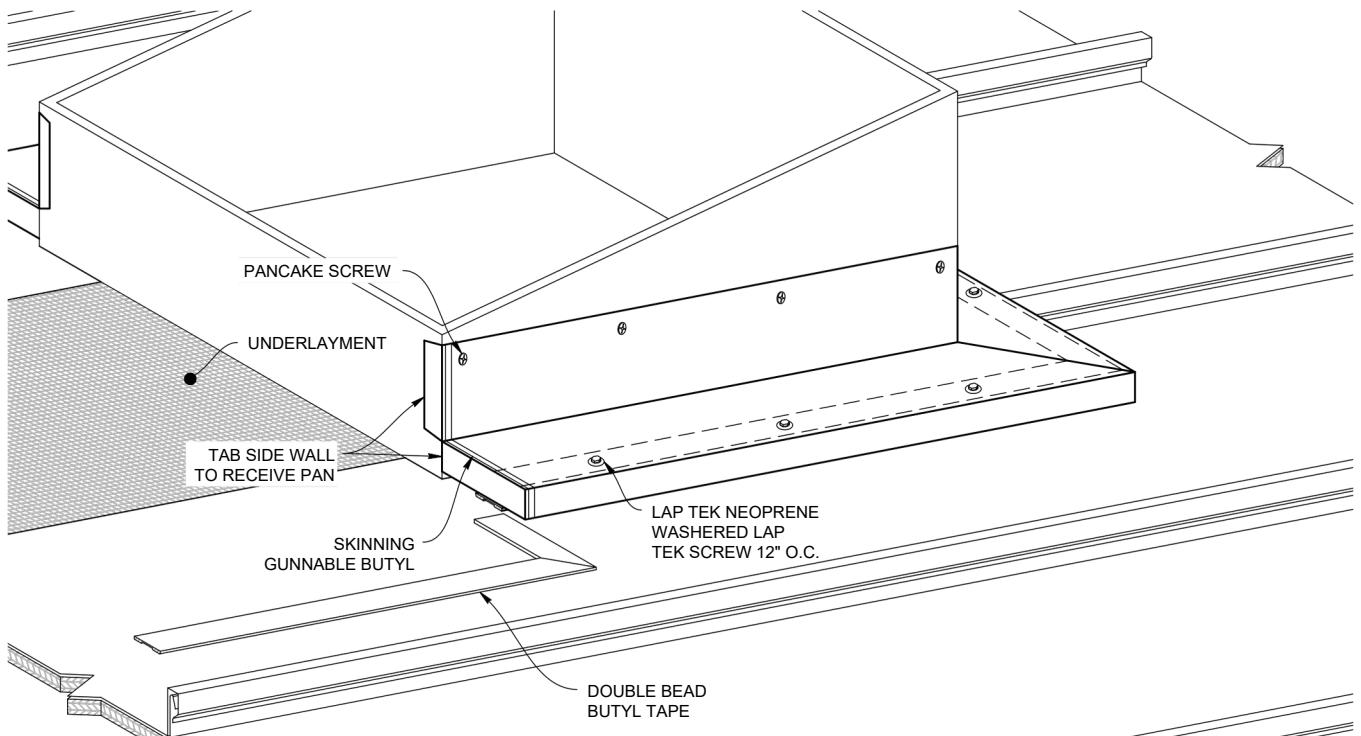

Note: All screws must be fastened into solid substrate.
Flashing must be lapped 4" with 3 rows of sealant.

STEP 3

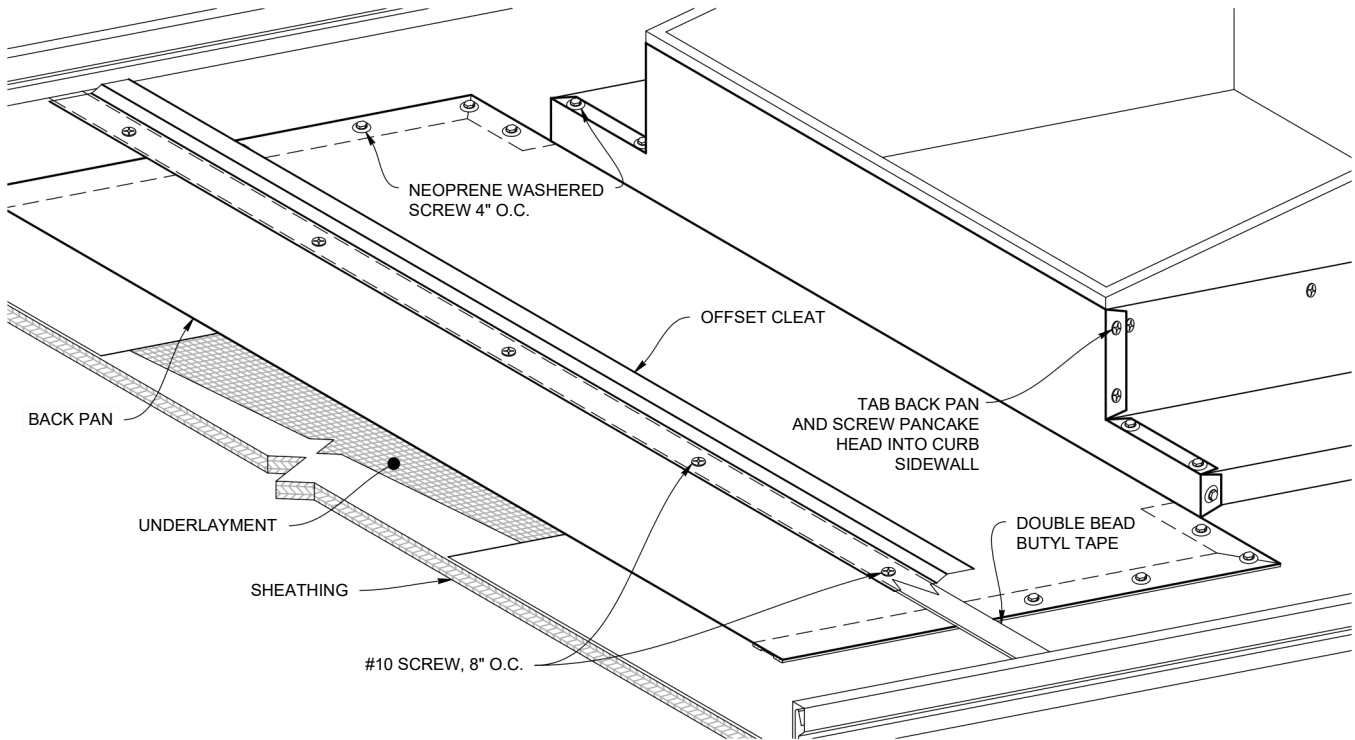

STEP 4

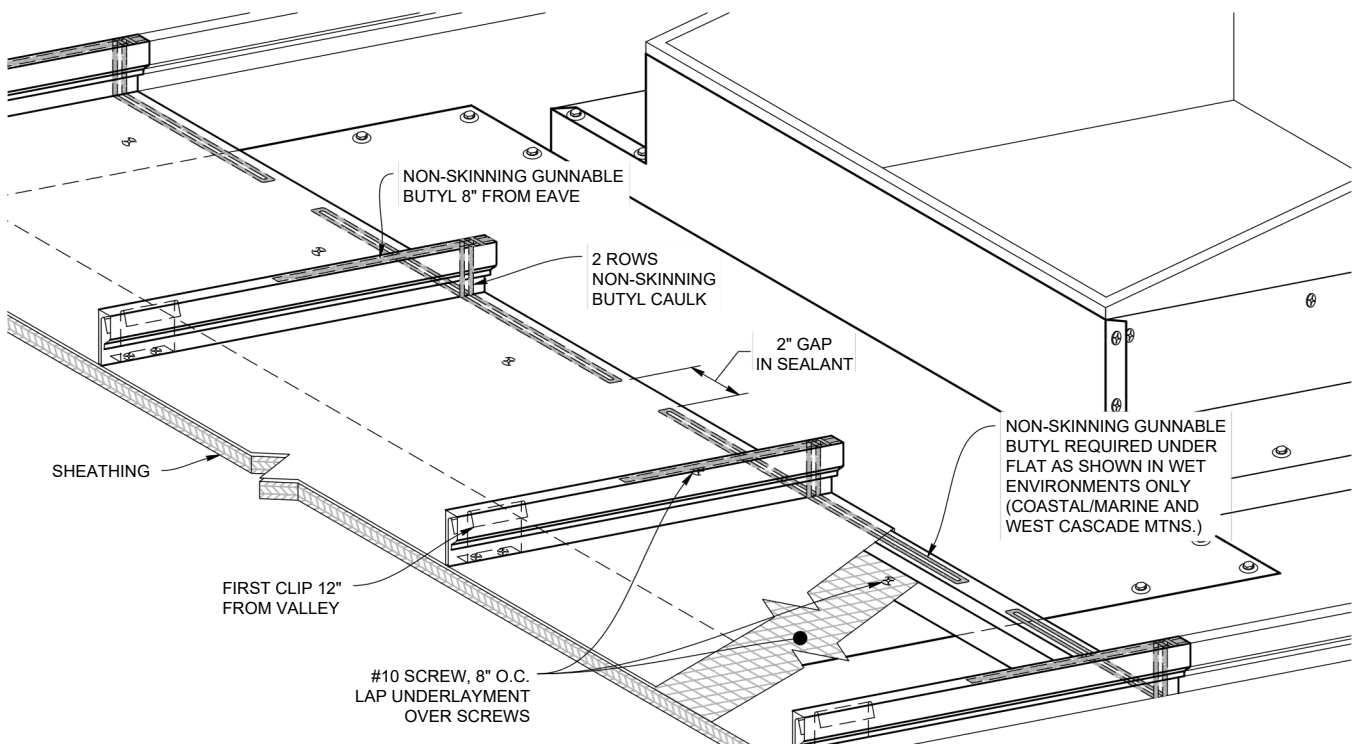

Note: All screws must be fastened into solid substrate.
Flashing must be lapped 4" with 3 rows of sealant.

STEP 5

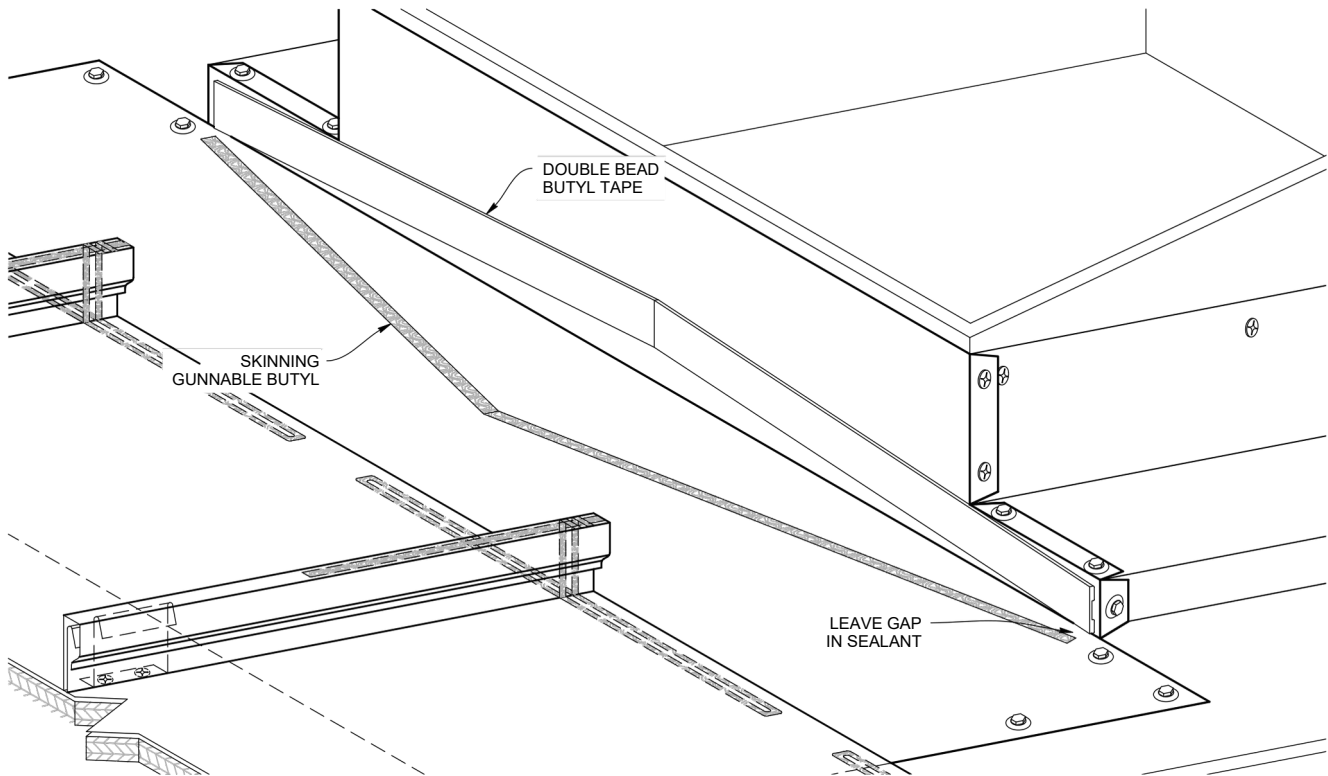

STEP 6

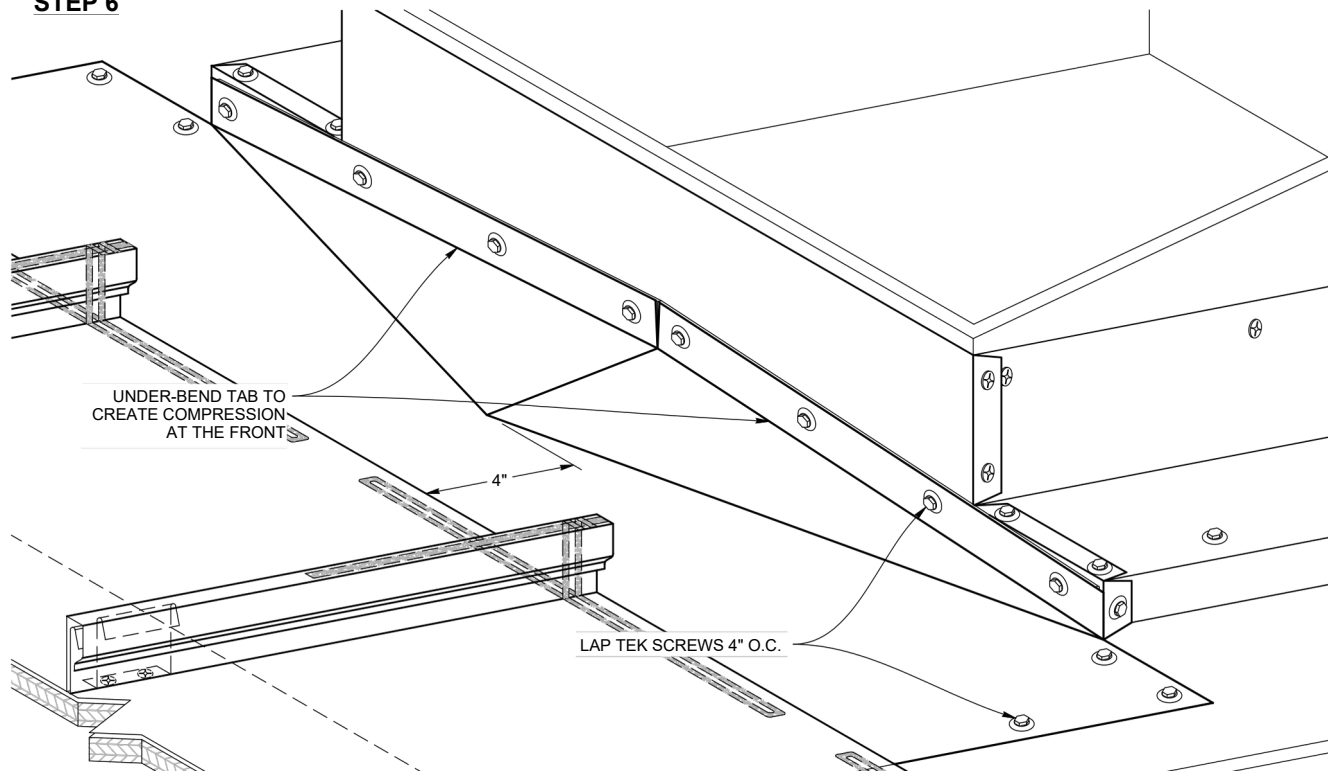

Note: All screws must be fastened into solid substrate.
Flashing must be lapped 4" with 3 rows of sealant.

CURB SIDEWALL DETAIL

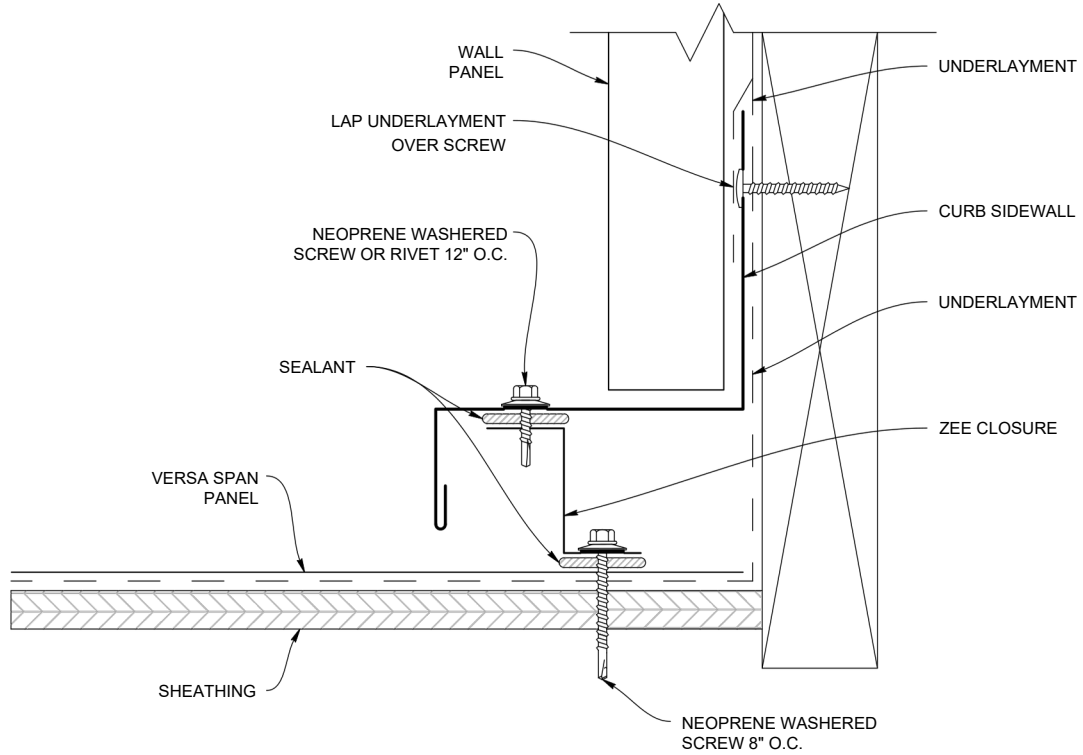

**ZEE CLOSURE
(VSZC)**

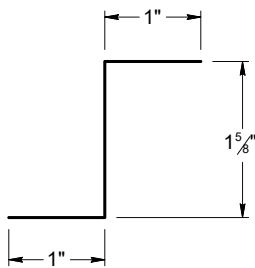

**CURB SIDEWALL
(VSCSW)**

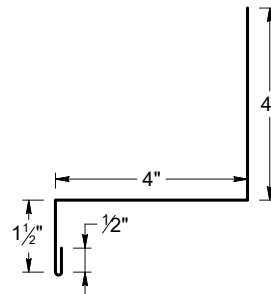

Note: All screws must be fastened into solid substrate.
Flashing must be lapped 4" with 3 rows of sealant.

CURB ENDWALL DETAIL

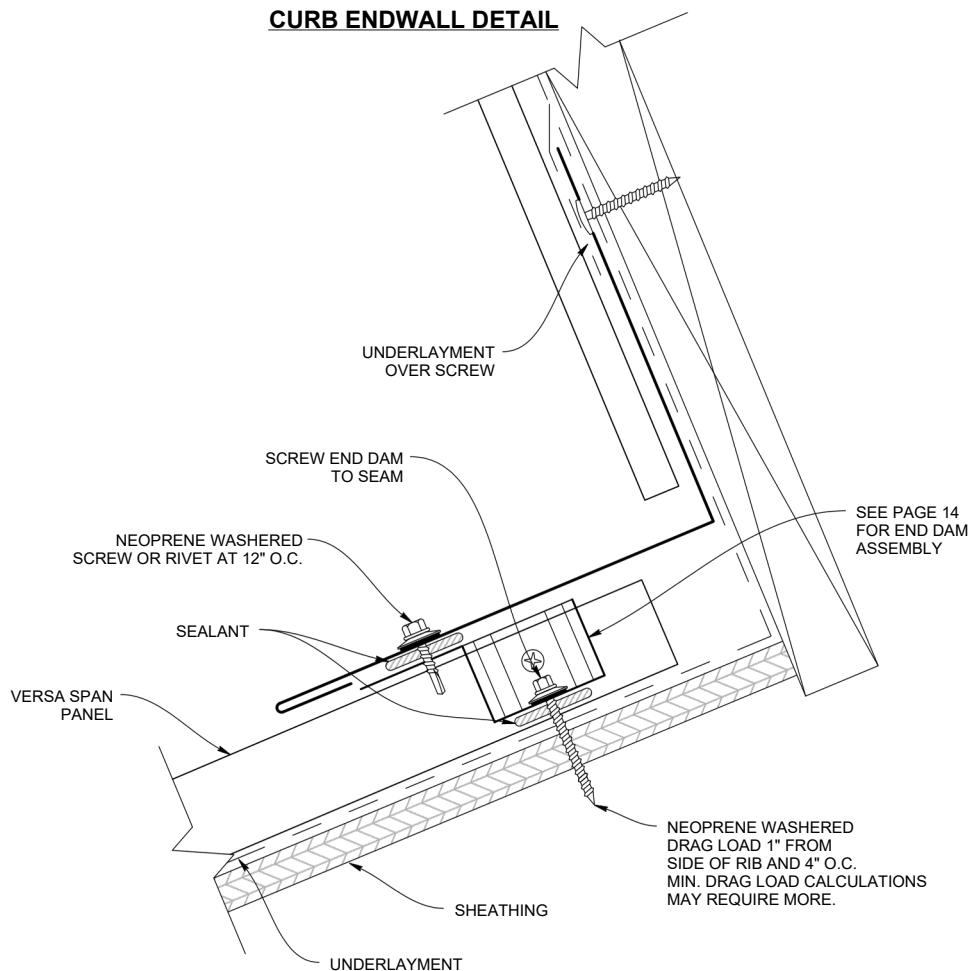

ENDWALL DETAIL

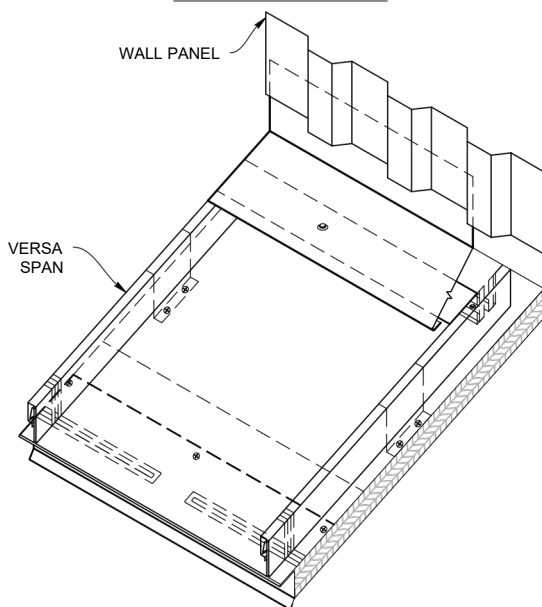

CURB SIDEWALL (VCSW)

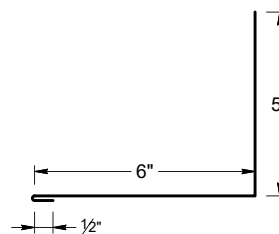

Note: All screws must be fastened into solid substrate.
Flashing must be lapped 4" with 3 rows of sealant.

CURB BACK PAN / CRICKET DETAIL (2:12 Pitch or Greater)

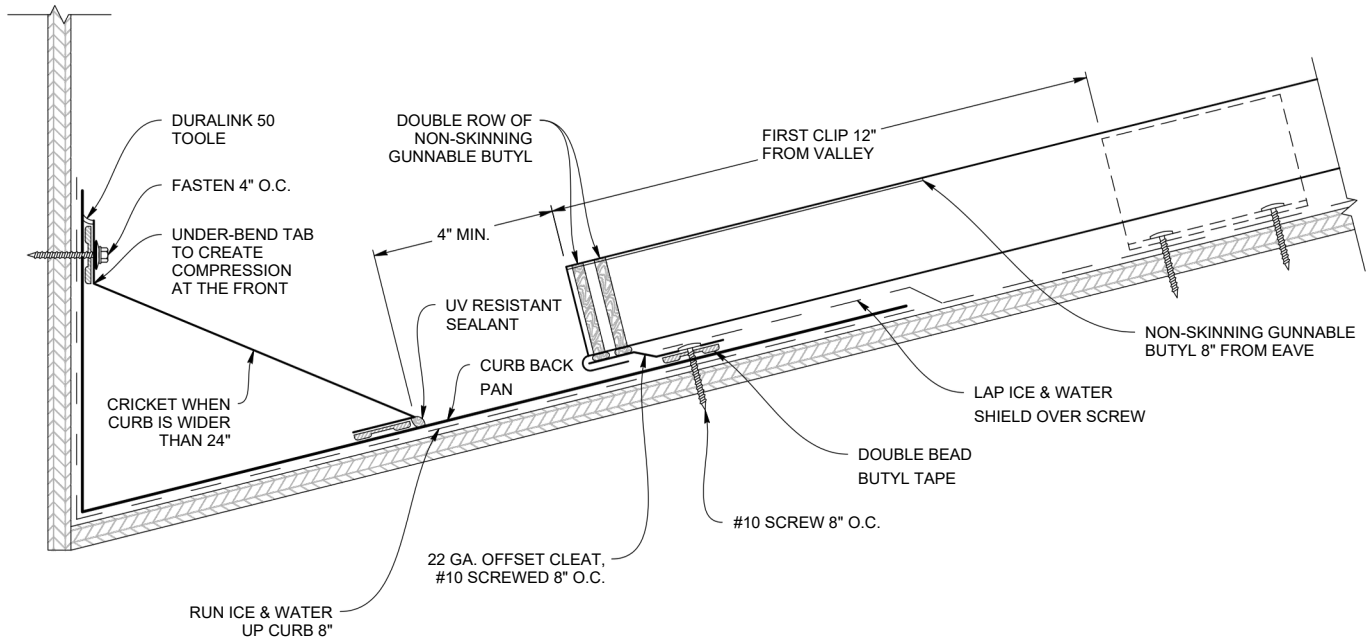

CURB BACK PAN / CRICKET DETAIL (Less Than 2:12 Pitch - Not recommended)

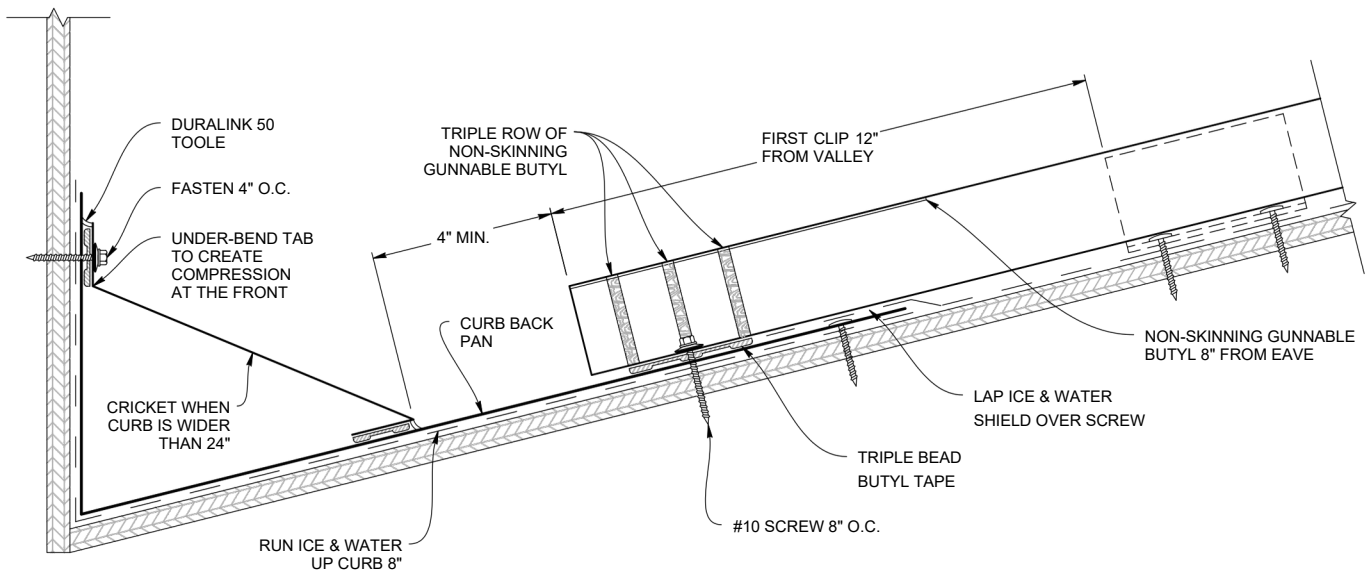

Note: All screws must be fastened into solid substrate.
Flashing must be lapped 4" with 3 rows of sealant.

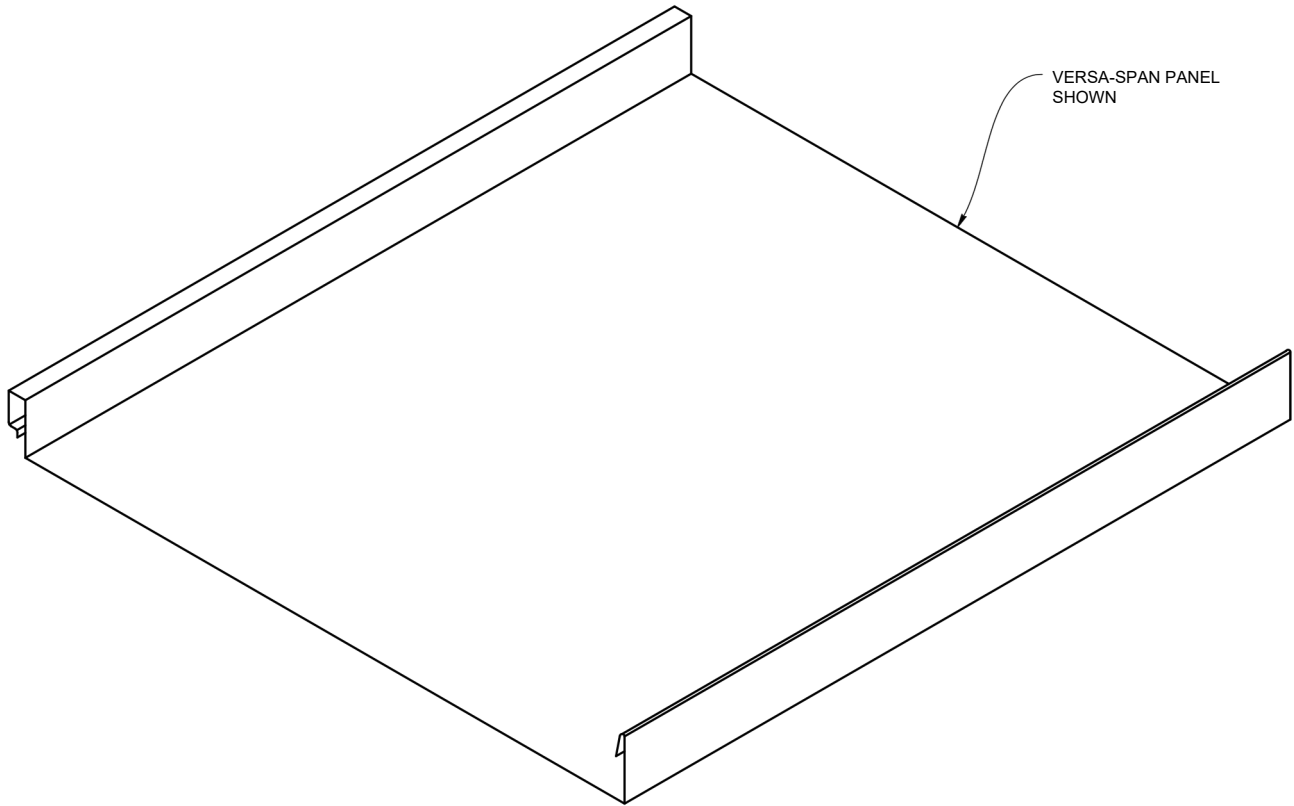

STEP 1

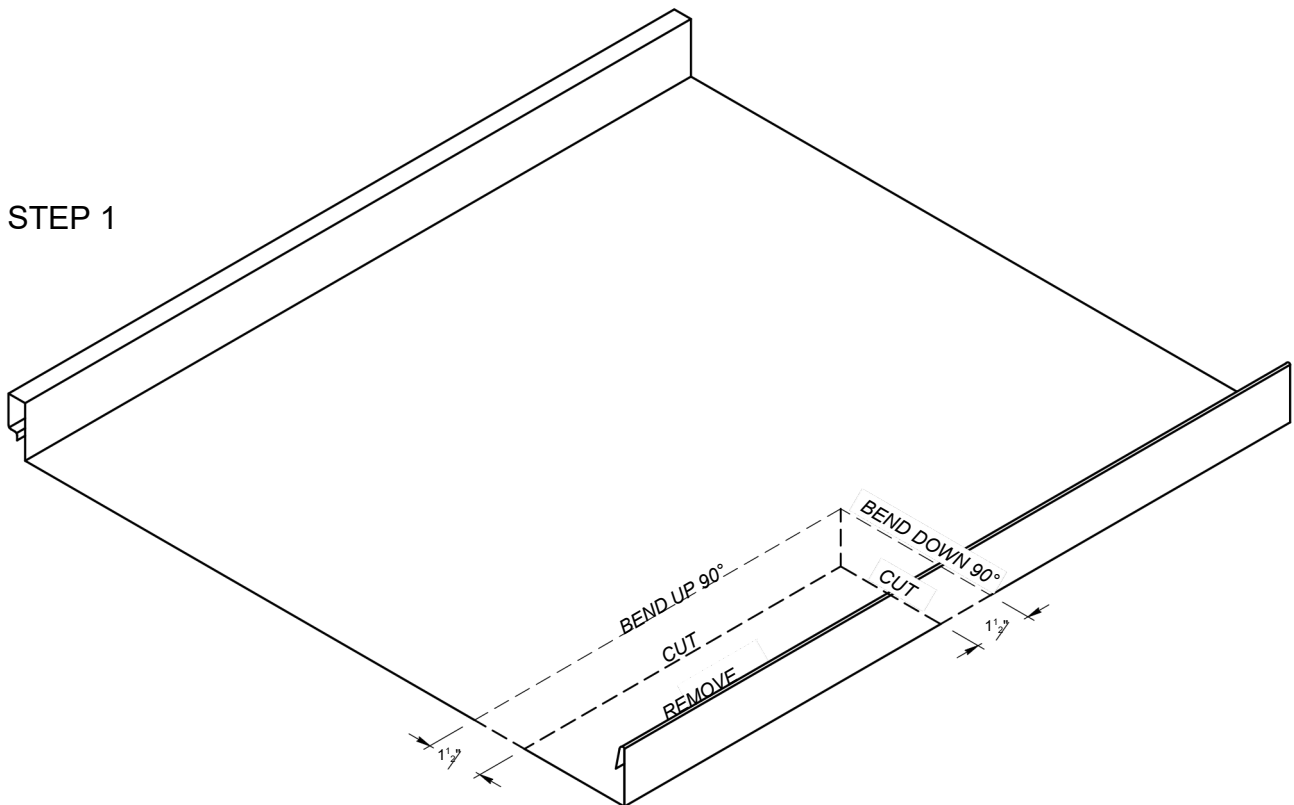

Note: All screws must be fastened into solid substrate.
Flashing must be lapped 4" with 3 rows of sealant.

STEP 2

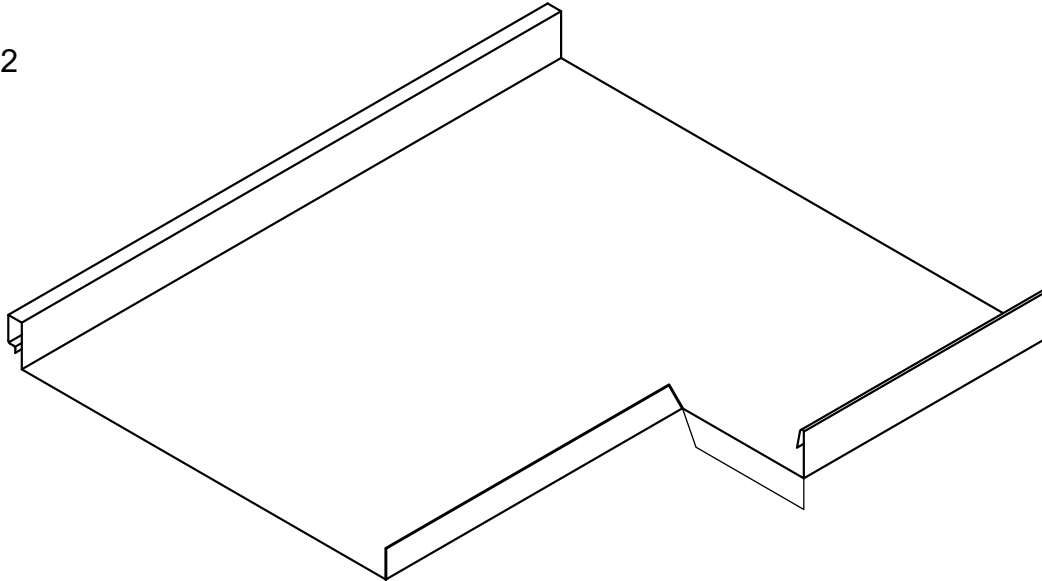

STEP 3

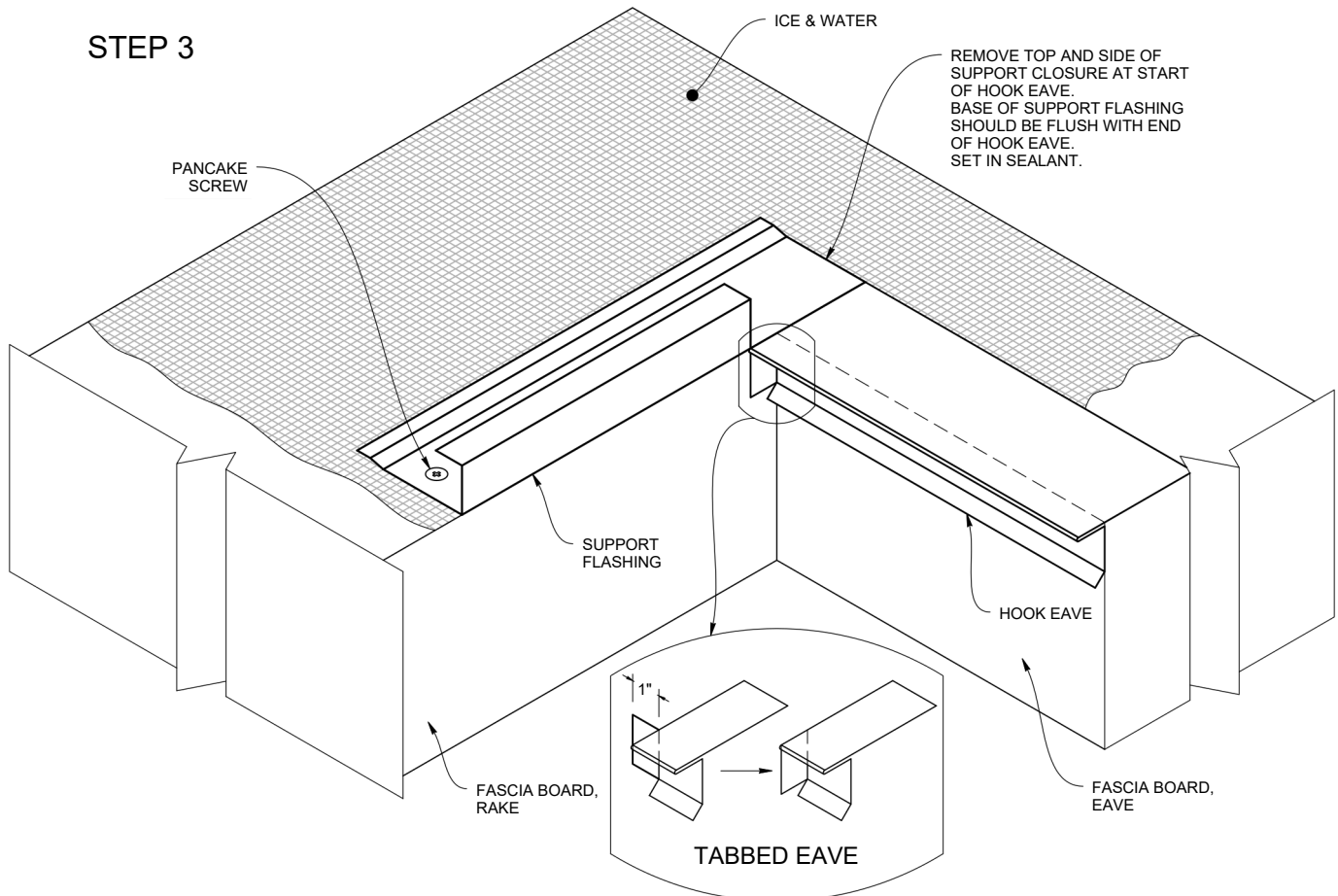

Note: All screws must be fastened into solid substrate.
Flashing must be lapped 4" with 3 rows of sealant.

STEP 4

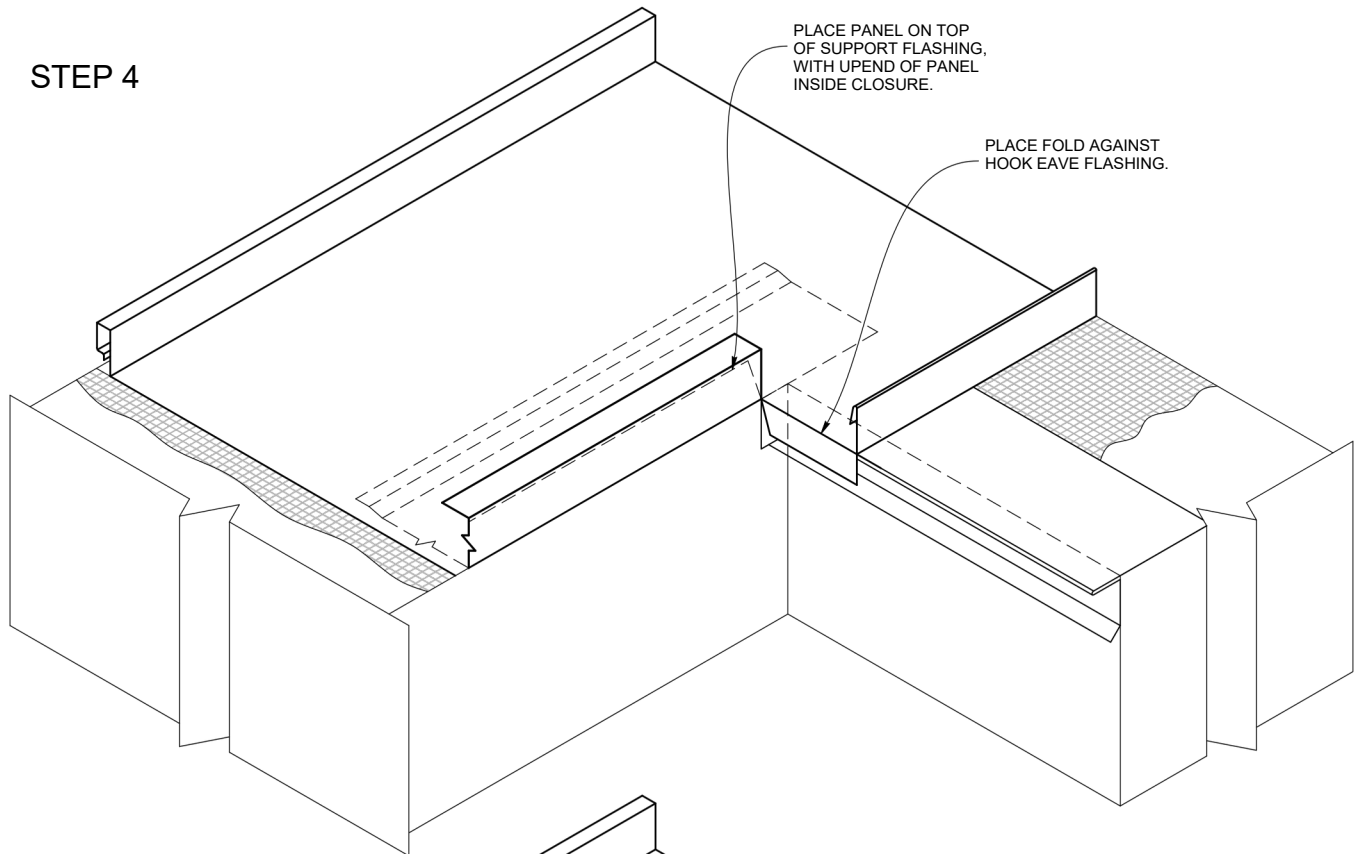

STEP 5

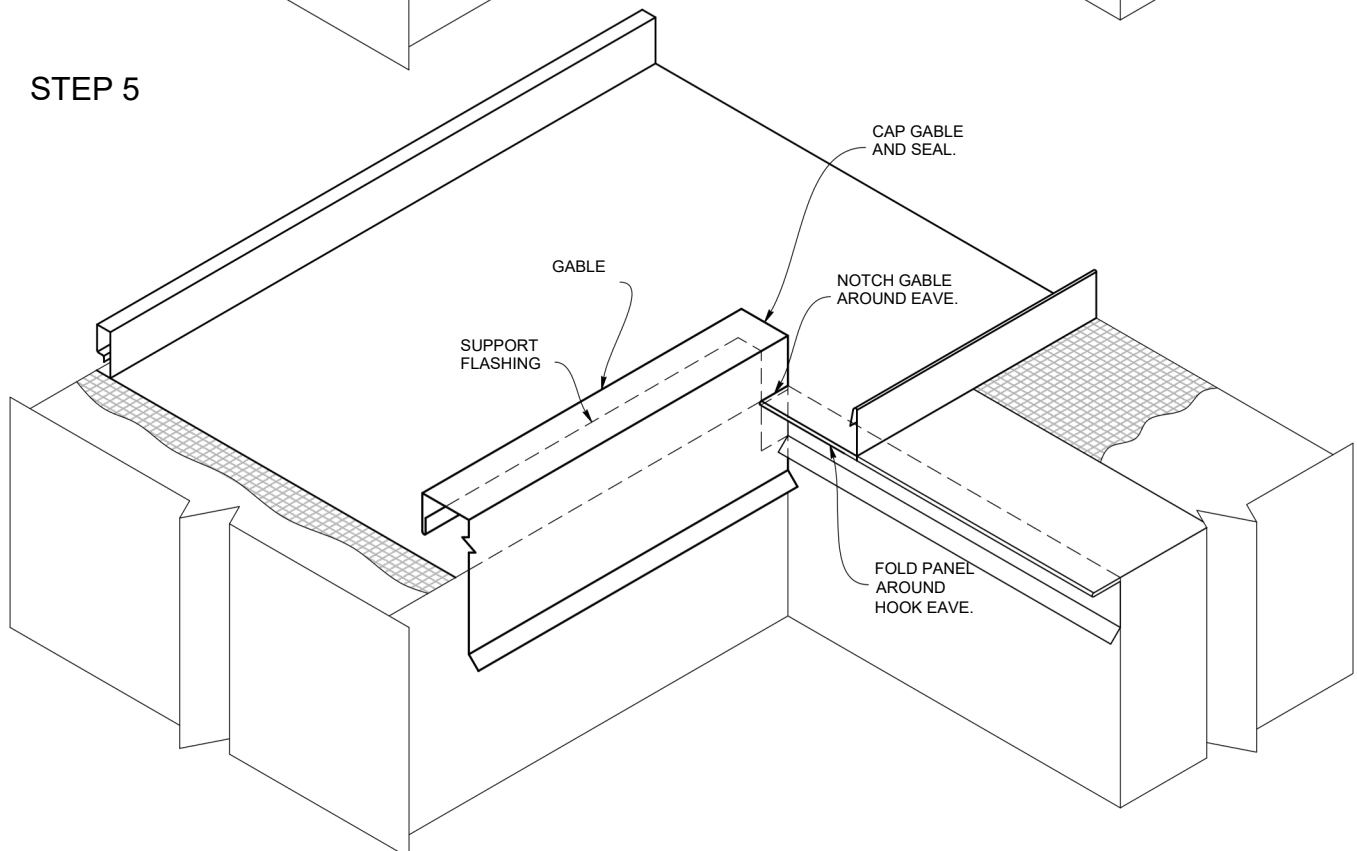

Note: All screws must be fastened into solid substrate.
Flashing must be lapped 4" with 3 rows of sealant.

FOR PIPES LOCATED OVER 20' FROM PIN POINT
 (Allows panel and pipe flashing to move with temperature change.)

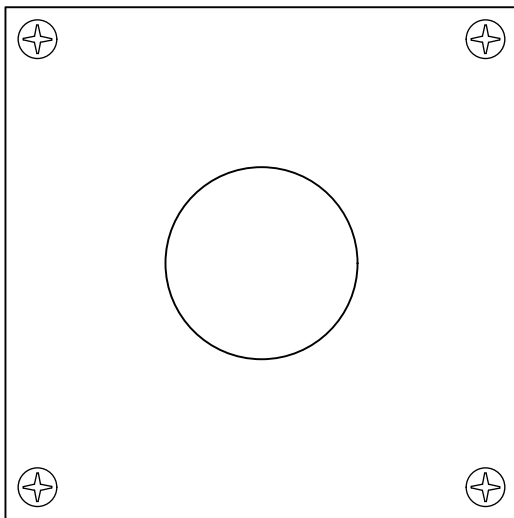
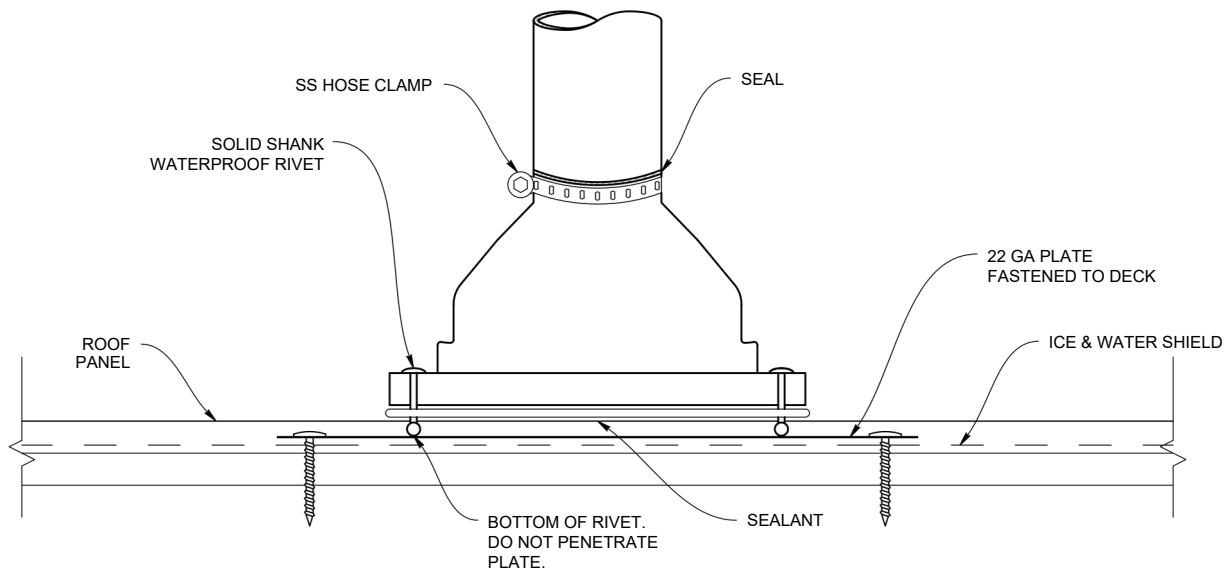

SINGLE 22 GAUGE PLATE

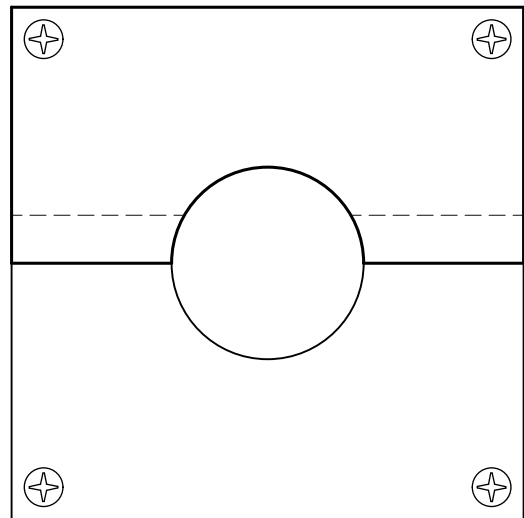

TWO OVERLAPPING 22 GAUGE PLATES

Note: All screws must be fastened into solid substrate.
 Flashing must be lapped 4" with 3 rows of sealant.

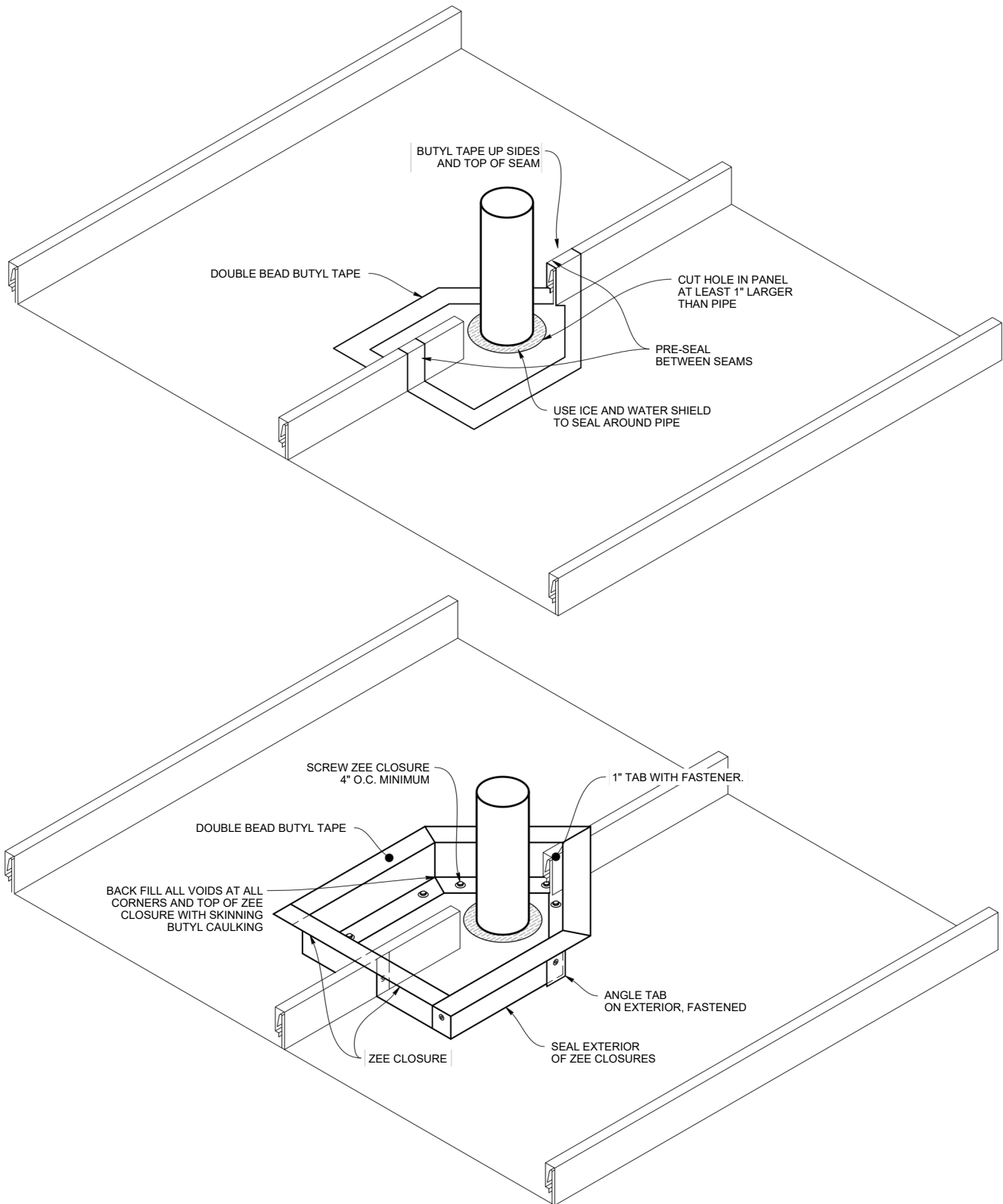

Note: All screws must be fastened into solid substrate.
Flashing must be lapped 4" with 3 rows of sealant.

Pipe Penetration - on Rib

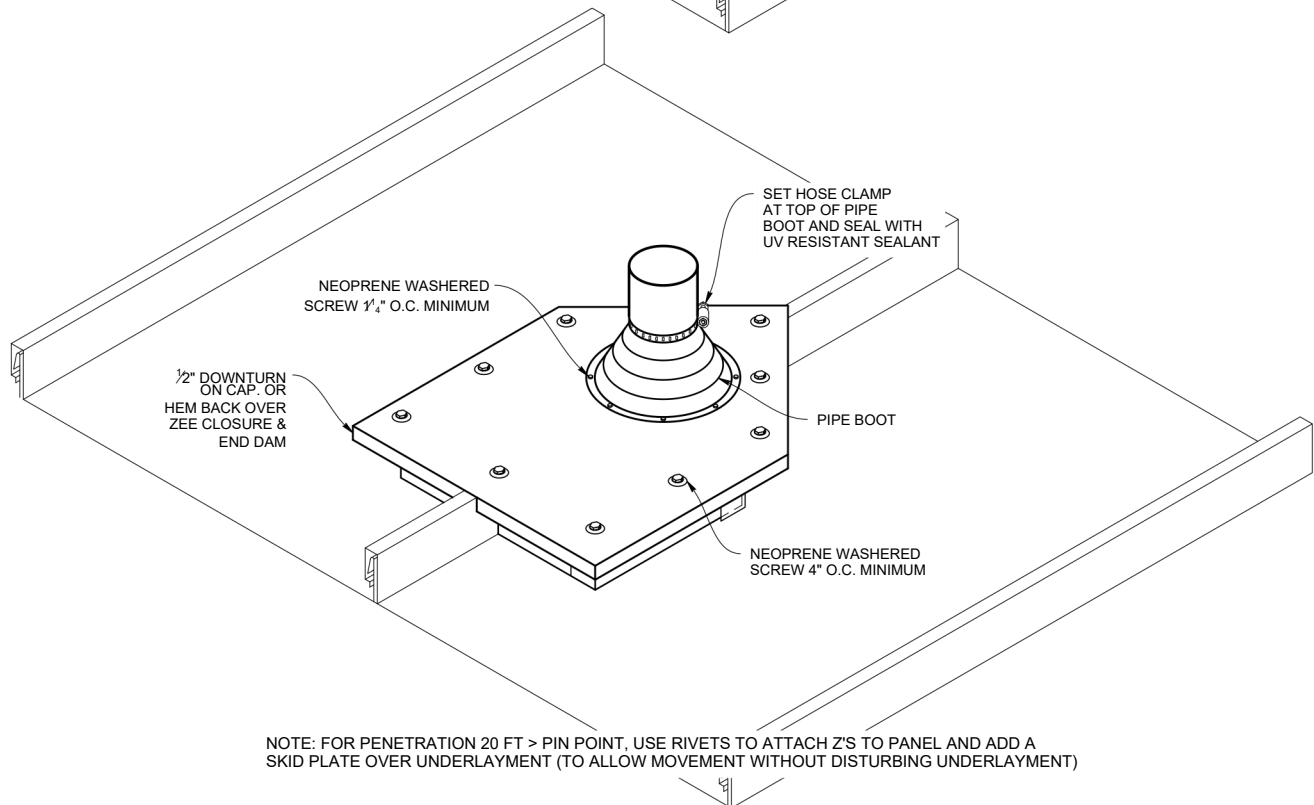
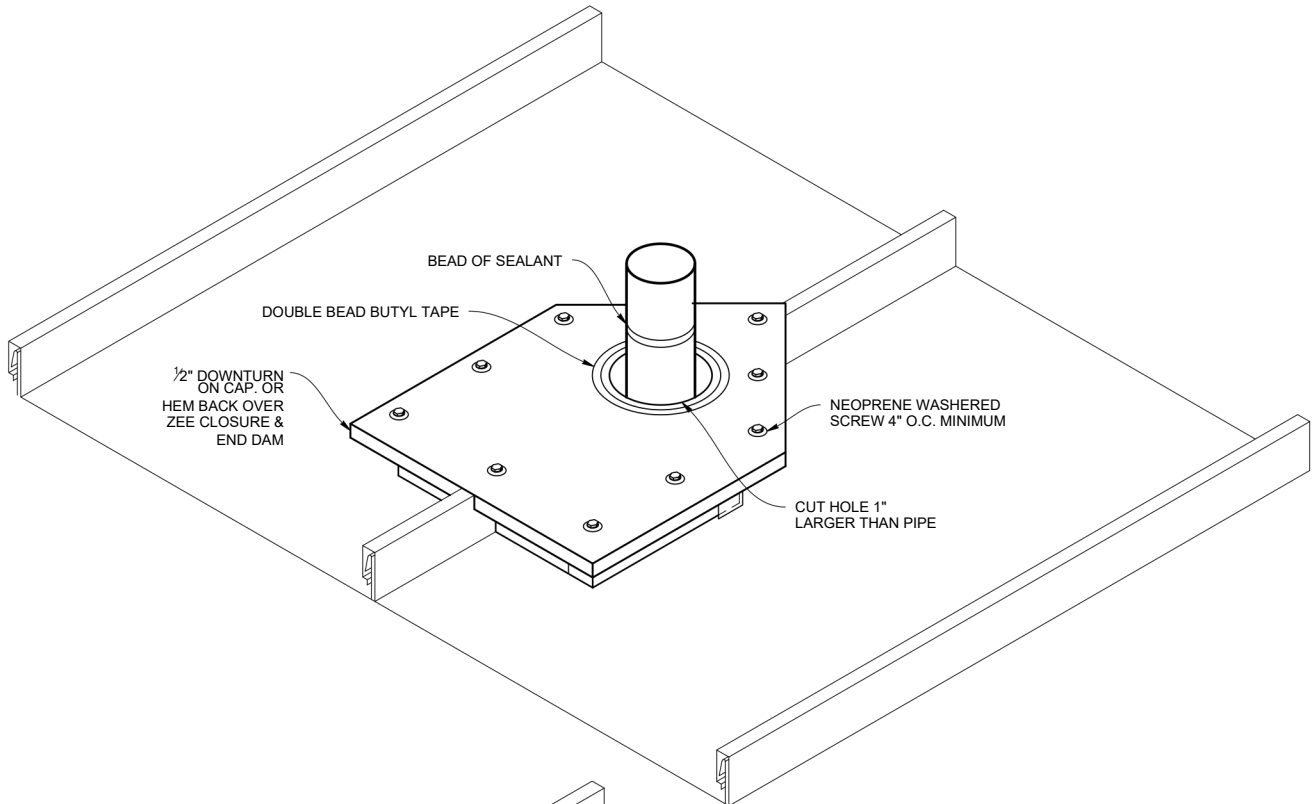

Note: All screws must be fastened into solid substrate.
Flashing must be lapped 4" with 3 rows of sealant.

Pipe Penetration - on Pan

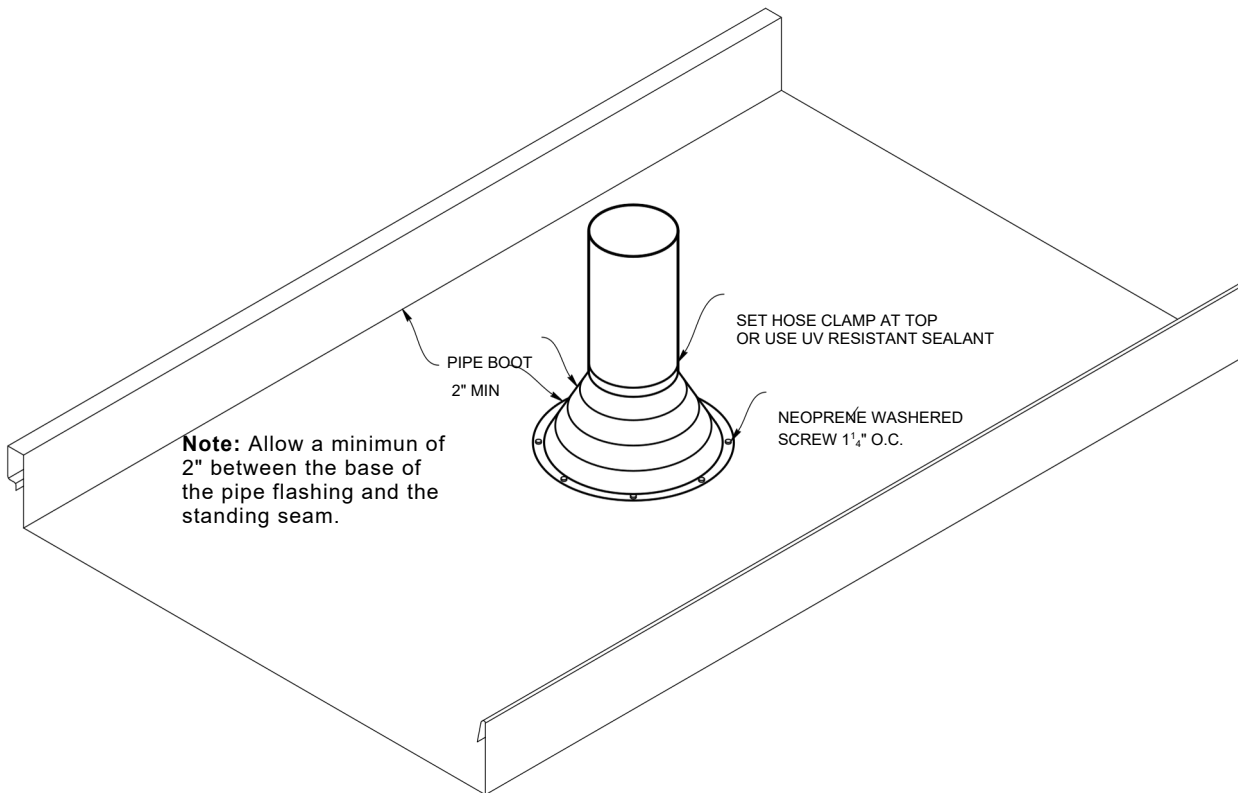
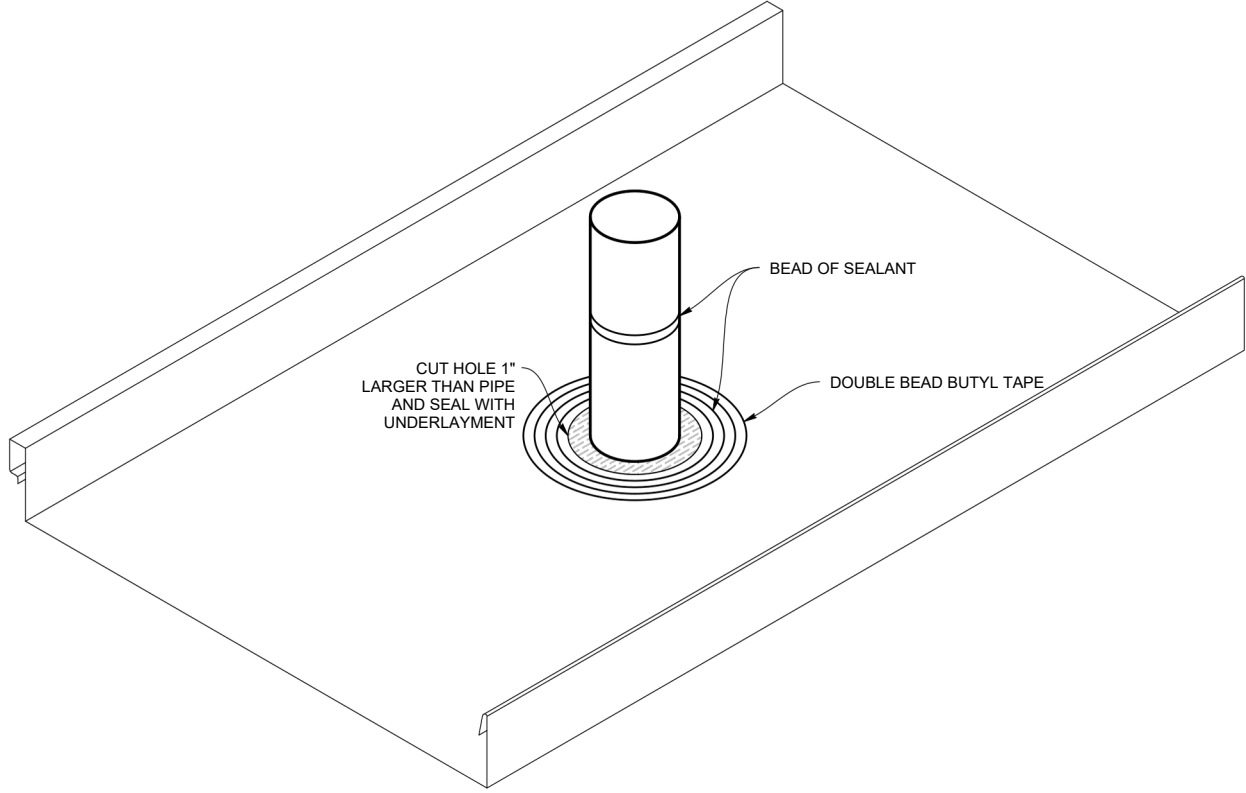

Note: All screws must be fastened into solid substrate.
Flashing must be lapped 4" with 3 rows of sealant.

<p>EAVE STANDARD (VSES)</p> <p>IF PAINTED, THIS SIDE 3 3/8" 1 1/2" SPECIFY PITCH 5/8" KICK, 1/2" HEM, OPEN</p> <p>SCALE 1:2 S.O. 6" WEIGHT: 4.9 LBS.</p>	<p>EAVE HOOK (VSEH)</p> <p>IF PAINTED, THIS SIDE 4 1/4" 1 1/8" SPECIFY PITCH 1 1/2" 5/8" KICK, 1/2" HEM, OPEN</p> <p>SCALE 1:2 S.O. 8" WEIGHT: 6.5 LBS.</p>	<p>OFFSET CLEAT (VSOC)</p> <p>NON-VISIBLE / SUB-FLASHINGS ARE NOT PROVIDED IN SPECIFIC COLORS UNLESS SPECIFIED</p> <p>1" 166° TYP. 1/2" 1 1/2"</p> <p>SCALE 1:2 S.O. 3" WEIGHT: 2.5 LBS.</p>
<p>GUTTER HANGER (AGH6)</p> <p>1/2" 1" 6"</p> <p>S.O. 8"</p> <p>WEIGHT: 6.5 LBS.</p> <p>SCALE 1:2</p>		
<p>BOX GUTTER (VS65BG)</p> <p>3/4" 1/2" HEM, OPEN 1" 1" 3/4" 4" 6" 5 1/2"</p> <p>SCALE 1:3 S.O. 16" WEIGHT: 13.1 LBS.</p>	<p>BOX GABLE (VSGB)</p> <p>1 3/4" 1 1/2" 1/2" 4 3/8" 5/8" KICK, 1/2" HEM, OPEN IF PAINTED, THIS SIDE</p> <p>SCALE 1:3 S.O. 9.25" WEIGHT: 7.5 LBS.</p>	<p>GABLESUPPORT CLEAT (VSGC)</p> <p>NON-VISIBLE / SUB-FLASHINGS ARE NOT PROVIDED IN SPECIFIC COLORS UNLESS SPECIFIED</p> <p>1" 4 1/4" 1/2"</p> <p>SCALE 1:3 S.O. 5.75" WEIGHT: 4.7 LBS.</p>

<p>ALTERNATE GABLE (VSAG)</p> <p>SCALE 1:3 S.O. 8.5" WEIGHT: 7 LBS.</p>	<p>ALTERNATE GABLE CLEAT (VSAGC)</p> <p>SCALE 1:3 S.O. 8.625" WEIGHT: 7 LBS.</p>	<p>SUPPORT FLASHING (VSSF)</p> <p>NON-VISIBLE / SUB-FLASHINGS ARE NOT PROVIDED IN SPECIFIC COLORS UNLESS SPECIFIED</p> <p>SCALE 1:3 S.O. 6.875" WEIGHT: 5.6 LBS.</p>
<p>PEAKFLASHING (RIDGE END CAP) (VSREC)</p> <p>SCALE 1:4 S.O. 14.5" WEIGHT: 11.8 LBS.</p>	<p>WTVENTEDPEAK FLASHING (VSWTREC)</p> <p>SCALE 1:4 S.O. 18.25" WEIGHT: 14.85 LBS.</p>	<p>PEAKCLEAT / VENTED PEAK CLEAT (VSRECC / VSVRECC)</p> <p>SCALE 1:3 S.O. 6.75" / 7.375" WEIGHT: 5.5 LBS.</p>
<p>STANDARD RIDGE (VSRS)</p> <p>SCALE 1:4 S.O. 16" WEIGHT: 13.1 LBS.</p>	<p>WT RIDGE VENTED (VSWTRFV)</p> <p>SCALE 1:6 S.O. 22.25" WEIGHT: 18.1 LBS.</p>	

**VALLEY WIDE FLASHING
(VSVFW)**

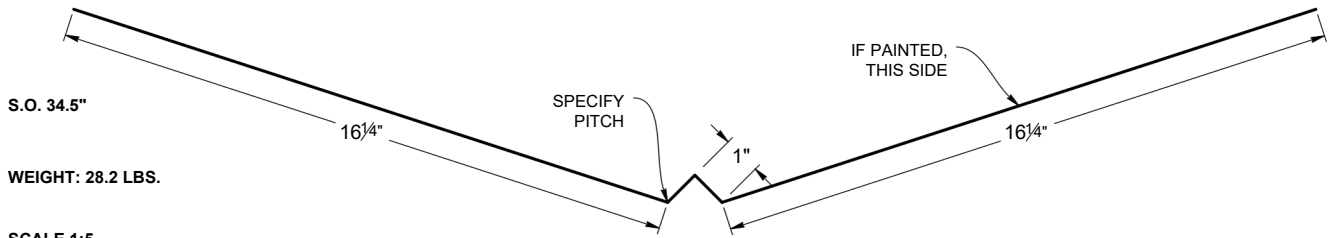

WEIGHT: 28.2 LBS.

SCALE 1:5

**VALLEY FLASHING
(VSVF)**

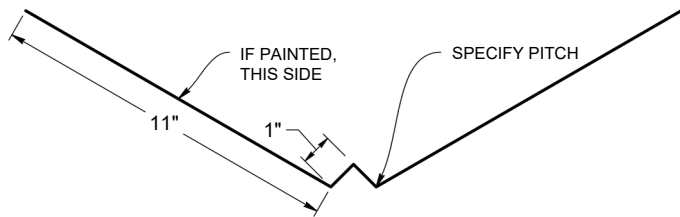

SCALE 1:6

S.O. 24"

WEIGHT: 19.7 LBS.

**OFFSET CLEAT
(VSOC)**

NON-VISIBLE / SUB-FLASHINGS
ARE NOT PROVIDED IN SPECIFIC
COLORS UNLESS SPECIFIED

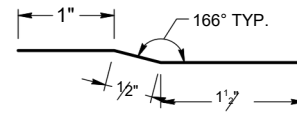

SCALE 1:2

S.O. 3"

WEIGHT: 2.5 LBS.

**CURB SIDEWALL
(VSCSW)**

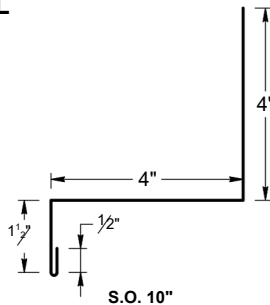

SCALE 1:4

S.O. 10"

WEIGHT: 8.2 LBS.

**SIDEWALL
(VSSW)**

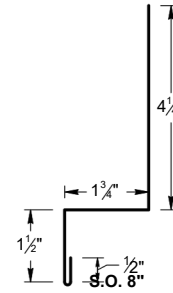

SCALE 1:4

WEIGHT: 6.6 LBS.

**ENDWALL
(VSEW)**

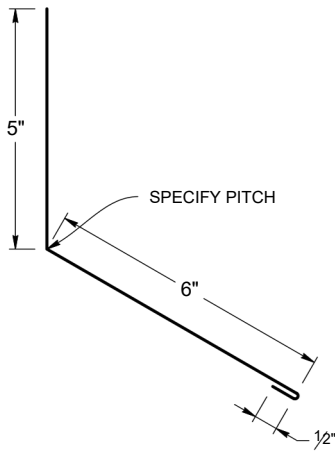

SCALE 1:4

S.O. 11.5"

WEIGHT: 9.8 LBS.

**WT VENTED ENDWALL
(VSWTEWW)**

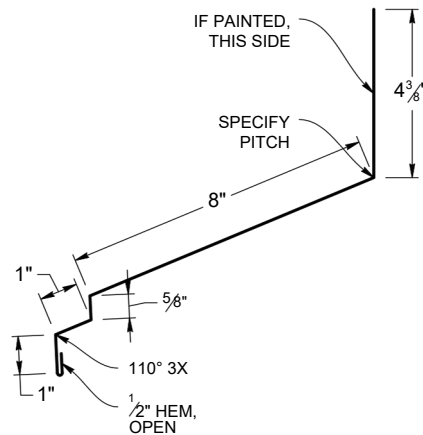

SCALE 1:4

S.O. 15.5"

WEIGHT: 12.6 LBS.

**CURB ENDWALL
(VSCH)**

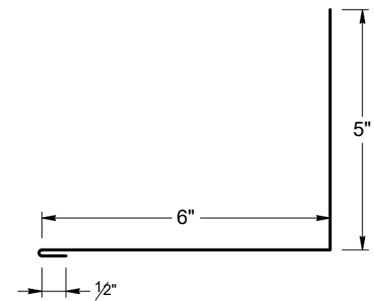

SCALE 1:4

S.O. 11.5"

WEIGHT: 9.8 LBS.

BACK PAN (VSPAN)

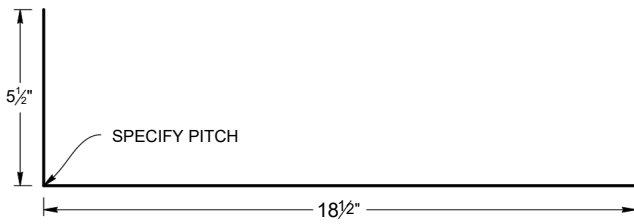

SCALE 1:4 S.O. 24" WEIGHT: 21.3 LBS.

REGLET (VSRF)

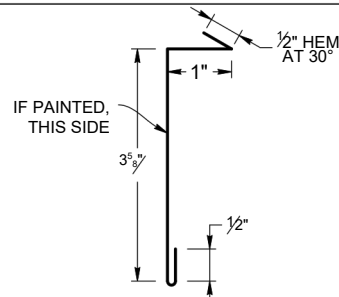

SCALE 1:3 S.O. 5.625" WEIGHT: 4.6 LBS.

VERSA-SPAN END DAM

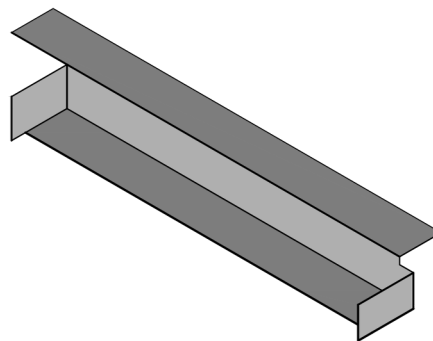

S.O. VARIES

WEIGHT: VARIES

SCALE 1:8

PERFORATED VENT DRIP E2886 EMBER RESISTANT (VSPVD)

NOTE: PERFORATED VENT DRIP IS COMPATIBLE WITH WT VENTED FLASHINGS ONLY

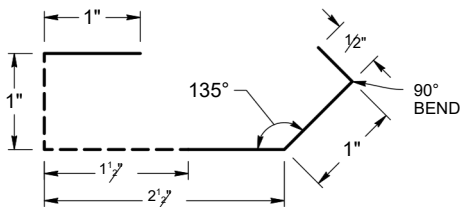

SCALE 1:2 S.O. 6" WEIGHT: 4.9 LBS.

NON-VISIBLE / SUB-FLASHINGS ARE NOT PROVIDED IN SPECIFIC COLORS UNLESS SPECIFIED

ZEE CLOSURE (VSZC)

NON-VISIBLE / SUB-FLASHINGS ARE NOT PROVIDED IN SPECIFIC COLORS UNLESS SPECIFIED

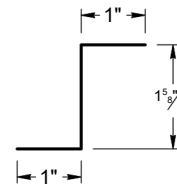

SCALE 1:3 S.O. 3.625" WEIGHT: 3 LBS.

OFFSET CLEAT (VSOC)

NON-VISIBLE / SUB-FLASHINGS ARE NOT PROVIDED IN SPECIFIC COLORS UNLESS SPECIFIED

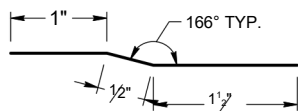

SCALE 1:2 S.O. 3" WEIGHT: 2.5 LBS.